

По вопросам продаж и поддержки обращайтесь:

Архангельск (8182)63-90-72	Краснодар (861)203-40-90	Рязань (4912)46-61-64
Астана (7172)727-132	Красноярск (391)204-63-61	Самара (846)206-03-16
Белгород (4722)40-23-64	Курск (4712)77-13-04	Санкт-Петербург (812)309-46-40
Брянск (4832)59-03-52	Липецк (4742)52-20-81	Саратов (845)249-38-78
Владивосток (423)249-28-31	Магнитогорск (3519)55-03-13	Смоленск (4812)29-41-54
Волгоград (844)278-03-48	Москва (495)268-04-70	Сочи (862)225-72-31
Вологда (8172)26-41-59	Мурманск (8152)59-64-93	Ставрополь (8652)20-65-13
Воронеж (473)204-51-73	Набережные Челны (8552)20-53-41	Тверь (4822)63-31-35
Екатеринбург (343)384-55-89	Нижний Новгород (831)429-08-12	Томск (3822)98-41-53
Иваново (4932)77-34-06	Новокузнецк (3843)20-46-81	Тула (4872)74-02-29
Ижевск (3412)26-03-58	Новосибирск (383)227-86-73	Тюмень (3452)66-21-18
Казань (843)206-01-48	Орел (4862)44-53-42	Ульяновск (8422)24-23-59
Калининград (4012)72-03-81	Оренбург (3532)37-68-04	Уфа (347)229-48-12
Калуга (4842)92-23-67	Пенза (8412)22-31-16	Челябинск (351)202-03-61
Кемерово (3842)65-04-62	Пермь (342)205-81-47	Череповец (8202)49-02-64
Киров (8332)68-02-04	Ростов-на-Дону (863)308-18-15	Ярославль (4852)69-52-93

Единый адрес: btk@nt-rt.ru **Веб-сайт:** www.burkert.nt-rt.ru

**Электромагнитные клапаны для
агрессивных и чистых сред Burkert**



Direct-acting 2/2 or 3/2-way solenoid valve

- Direct-acting, media-separated valve up to DN 25
- Vibration resistant, block mounted coil system
- Energy saving power reduction for DC versions
- High safety due to electrical position feedback
- Robust, service friendly manual override

The valve operates according to the lever principle and can therefore switch big orifices directly. Available in 2/2-way version as well as a 3/2-way valve. The armature works horizontally on a tightly coupled toggle. The cylinder seal, located at the lower lever, is pressed by the horizontal movement of the valve seat. The plastic-coated metal lever forms a unit with the implemented gas-tight membrane. With this construction the actuator is disconnected from the media fluid housing.

Circuit function A

2/2-way valve, direct-acting,
Normally closed

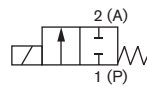

Circuit function B

2/2-way valve, direct-acting,
normally open

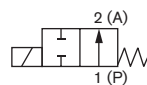

Circuit function C

3/2-way valve, direct-acting,
in de-energized position,
port A exhausted

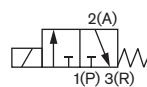

Circuit function D

3/2-way valve, direct acting,
in de-energized position,
port B pressurized

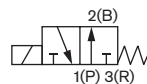

Circuit function E

mixer valve, direct-acting,
in de-energized position,
P2→A open, P1 closed

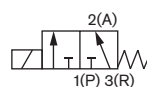

Circuit function F

distribution valve, direct-acting,
in de-energized passage,
P→B open

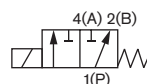

Technical data	
Body material	PVC, PVDF, brass
Seal material	NBR, EPDM, FKM
Medium	Aggressive and non-aggressive fluids, neutral gases, aggressive gases according to their diffusion properties
Medium temperature (Body + Seal)	PVC / EPDM -10 to +50 °C PVC / FKM -10 to +50 °C Brass / EPDM -30 to +130 °C * Brass / FKM -10 to +130 °C * Brass / NBR -10 to +90 °C PVDF / FKM -10 to +70 °C PVDF / EPDM -10 to +70 °C
Ambient temperature	Max. +50 °C
Viscosity	37 mm ² /s
Operating voltage	24 V / UC, 230 V / UC, 24 V / 50 Hz, 230 V / 50 Hz
Voltage tolerance	±10 %
Cycling rate	60/min at AC Max. 6/min at UC
Duty cycle	100%
Electrical connection	Cable plug (supplied as standard)
Protection class	IP65 with cable plug
Installation	As required, preferably with actuator upright

* High performance version, AC/DC max. +90 °C

Response times [ms]:	Measured at valve outlet at 6 bar and +20°C.
Opening (10 to 20)	Pressure rise 0 to 90%,
Closing (40 to 60)	Pressure relief 100 to 10%

Electrical power consumption			
Inrush	Hold		
AC [VA]	UC [W]	AC [VA/W]	UC [W]
100-120	100	48/16	9

Flow rate: Kv value water [m³/h]

Measured at +20 °C, 1 bar pressure at valve inlet and free outlet

Pressure values [bar]

Overpressure with respect to atmospheric pressure

Materials

3/2-way brass version

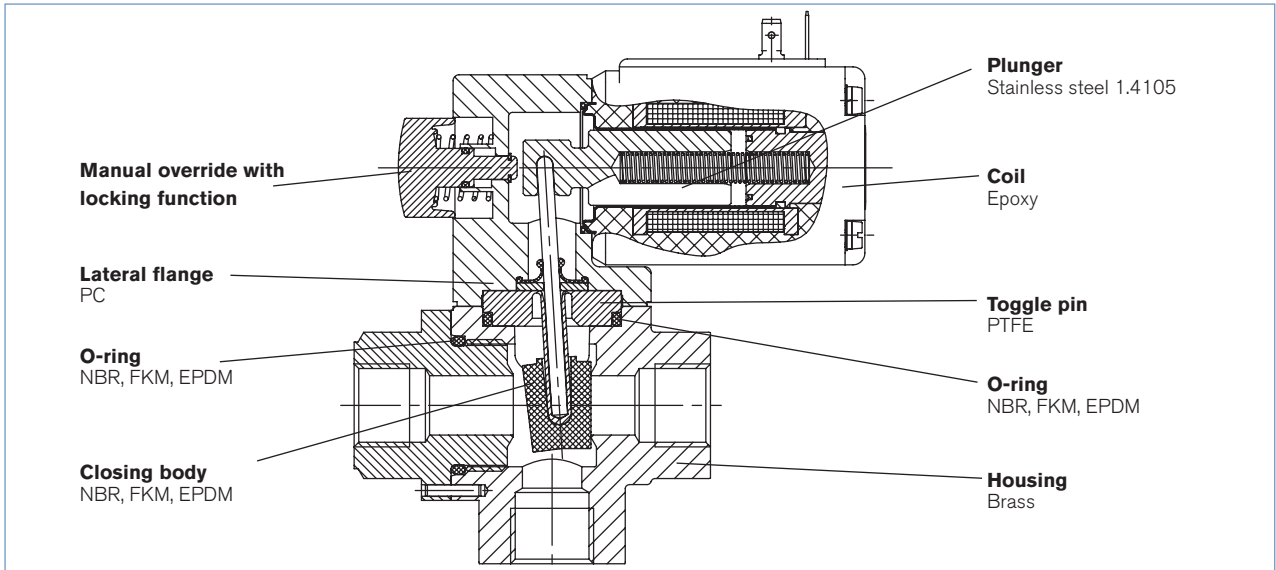

Dimensions [mm]

3/2-way brass version

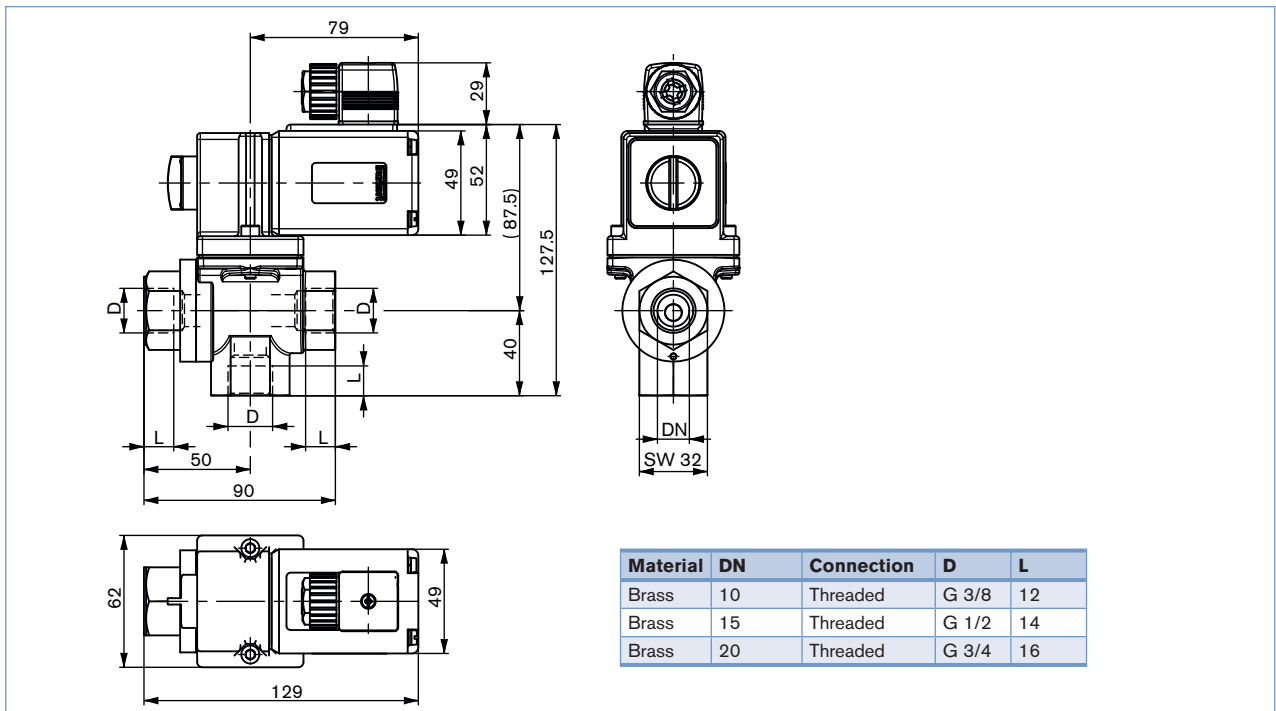

Ordering chart for valves

3/2-way version, seal material EPDM

Body material	Circuit function	Orifice [mm]	Port connection [inch resp. mm]	Kv value water [m ³ /h]	Pressure range [bar]	Item no. per voltage / frequency			
						24 V/UC	230 V/UC	24 V/50 Hz	230 V/50 Hz
PVC	C	10	G 3/8	2.0	0-1	x	x	-	-
			G 1/2	2.0	0-1	x	x	-	-
			True union Ø 16	2.0	0-1	x	x	-	-
			True union Ø 20	2.0	0-1	x	x	-	-
		15	G 1/2	4.0	0-0.5	x	x	-	-
			True union Ø 20	4.0	0-0.5	x	x	-	-
			True union Ø 25	4.0	0-0.5	x	x	-	-
		20	G 3/4	5.0	0-0.25	x	x	-	-
			True union Ø 25	5.0	0-0.25	x	x	-	-
	D	10	G 3/8	2.0	0-1	x	x	x	x
			G 1/2	2.0	0-1	x	x	x	x
			True union Ø 16	2.0	0-1	x	x	x	x
			True union Ø 20	2.0	0-1	x	x	x	x
		15	G 1/2	4.0	0.5	x	x	x	x
			True union Ø 20	4.0	0.5	x	x	x	x
			True union Ø 25	4.0	0.5	x	x	x	x
		20	G 3/4	5.0	0-0.25	x	x	x	x
			True union Ø 25	5.0	0-0.25	x	x	x	x
	F	10	G 3/8	2.0	0-1	x	x	x	x
			G 1/2	2.0	0-1	x	x	076 537	x
			True union Ø 16	2.0	0-1	055 770	x	064 266	052 546
			True union Ø 20	2.0	0-1	x	x	x	x
		15	G 1/2	4.0	0.5	025 876	x	x	x
True union Ø 20			4.0	0.5	049 883	x	058 279	052 071	
True union Ø 25			4.0	0.5	x	x	x	x	
20		G 3/4	5.0	0-0.25	x	x	x	x	
		True union Ø 25	5.0	0-0.25	067 076	x	040 921	054 564	
PVDF	F	10	Weld end Ø 16	2.0	0-1	x	x	x	x
		15	Weld end Ø 20	4.0	0-0.5	x	x	x	x
		20	Weld end Ø 25	5.0	0-0.25	x	x	x	x
Brass	C	10	G 3/8	2.0	0-1	x	x	-	-
		15	G 1/2	4.0	0-0.5	046 648	x	-	-
		20	G 3/4	5.0	0-0.25	x	x	-	-
	D	10	G 3/8	2.0	0-1	x	x	x	x
		15	G 1/2	4.0	0-0.5	x	x	x	x
		20	G 3/4	5.0	0-0.25	x	x	x	x
	F	10	G 3/8	2.0	0-1	x	x	x	x
		15	G 1/2	4.0	0-0.5	x	x	x	053 634
		20	G 3/4	5.0	0-0.25	x	x	x	x

3/2-way version, seal material NBR

Body material	Circuit function	Orifice [mm]	Port connection [inch]	Kv value water [m ³ /h]	Pressure range [bar]	Item no. per voltage / frequency			
						24 V/UC	230 V/UC	24 V/50 Hz	230 V/50 Hz
Brass	C	10	G 3/8	2.0	0-1	048 997	059 302	-	-
		15	G 1/2	4.0	0-0.5	062 737	062 481	-	-
		20	G 3/4	5.0	0-0.25	x	049 470	-	-
	D	10	G 3/8	2.0	0-1	x	x	x	x
		15	G 1/2	4.0	0-0.5	021 964	x	x	051 556
		20	G 3/4	5.0	0-0.25	x	x	x	x
	F	10	G 3/8	2.0	0-1	064 025	x	x	062 960
		15	G 1/2	4.0	0-0.5	x	x	045 916	062 124
		20	G 3/4	5.0	0-0.25	140 798	x	062 119	079 567

X on request

- version not possible

Ordering chart for valves

3/2-way version, seal material FKM

Body material	Circuit function	Orifice [mm]	Port connection [inch resp. mm]	Kv value water [m ³ /h]	Pressure range [bar]	Item no. per voltage / frequency					
						24 V/UC	230 V/UC	24 V/50 Hz	230 V/50 Hz		
PVC	C	10	G 3/8	2.0	0-1	x	x	-	-		
			G 1/2			x	x	-	-		
			True union Ø 16			x	x	-	-		
			True union Ø 20			x	x	-	-		
		15	G 1/2	4.0	0-0.5	x	x	-	-		
			True union Ø 20			x	x	-	-		
			True union Ø 25			x	x	-	-		
		20	G 3/4	5.0	0-0.25	x	x	-	-		
			True union Ø 25			x	x	-	-		
	D	10	10	G 3/8	2.0	0-1	x	x	x	x	
				G 1/2			x	x	x	x	
				True union Ø 16			x	x	x	x	
				True union Ø 20			x	x	x	172 866	
			15	G 1/2	4.0	0-0.5	x	x	x	x	
				True union Ø 20			x	x	x	x	
		20	True union Ø 25	4.0	0-0.5	x	x	x	x		
			G 3/4			5.0	0-0.25	x	x	x	x
			True union Ø 25						x	x	x
		F	10	10	G 3/8	2.0	0-1	065 194	x	x	052 183
					G 1/2			x	x	x	x
					True union Ø 16			058 362	x	x	052 619
True union Ø 20	x				x			x	x		
15	G 1/2			4.0	0.5	x	x	x	x		
	True union Ø 20					058 710	x	x	050 904		
20	True union Ø 25		4.0	0-0.25	x	020 687	x	042 470			
	G 3/4				5.0	0-0.25	x	x	x	x	
	True union Ø 25							058 363	x	068 352	066 280
PVDF	C		10	Weld end Ø 16	2.0	0-1	x	x	-	-	
			15	Weld end Ø 20	4.0	0-0.5	x	x	-	-	
			20	Weld end Ø 25	5.0	0-0.25	x	x	-	-	
	E	15	G 1/2	4.0	0-0.3	208100	x	-	-		
	F	10	Weld end Ø 16	2.0	0-1	x	x	x	235041		
		15	Weld end Ø 20	4.0	0-0.5	x	x	x	x		
20		Weld end Ø 25	5.0	0-0.25	x	x	x	x			
Brass	C	10	G 3/8	2.0	0-1	x	x	-	-		
		15	G 1/2	4.0	0-0.5	x	x	-	-		
		20	G 3/4	5.0	0-0.25	x	x	-	-		
		D	10	G 3/8	2.0	0-1	x	x	x	x	
			15	G 1/2	4.0	0-0.5	x	x	x	x	
			20	G 3/4	5.0	0-0.25	x	x	x	x	
	F	10	G 3/8	2.0	0-1	x	x	x	x		
		15	G 1/2	4.0	0-0.5	053 050	069 814	x	058 915		
		20	G 3/4	5.0	0-0.25	x	x	x	x		

X on request
 - version not possible

Materials

2/2-way brass version

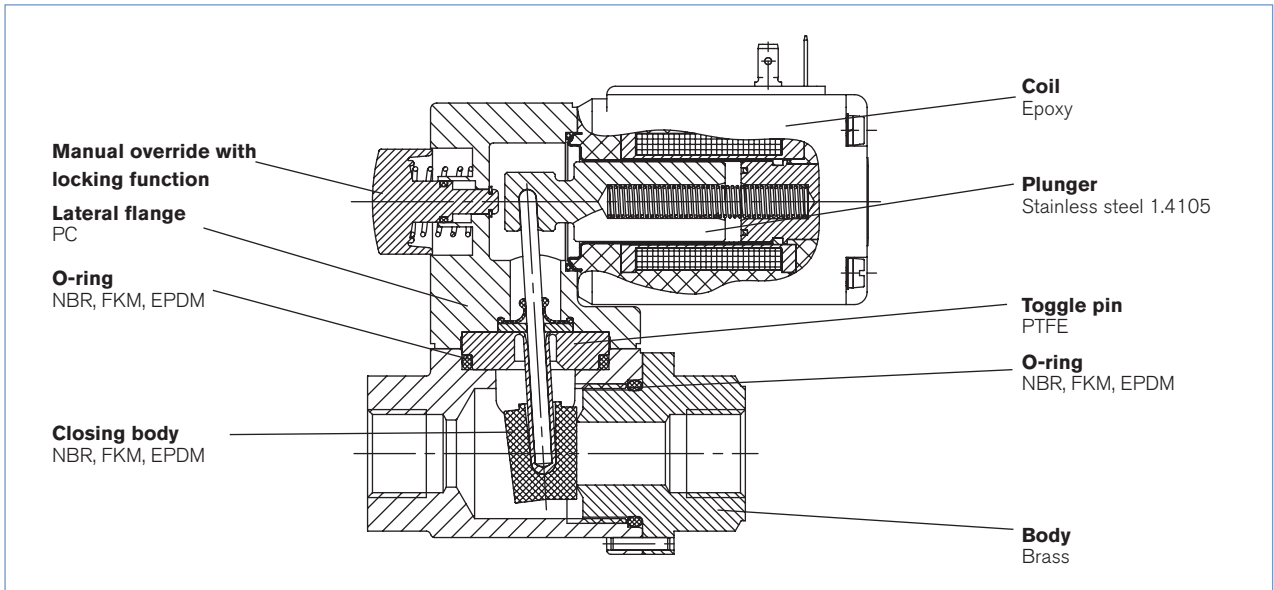

Dimensions [mm]

2/2-way brass version

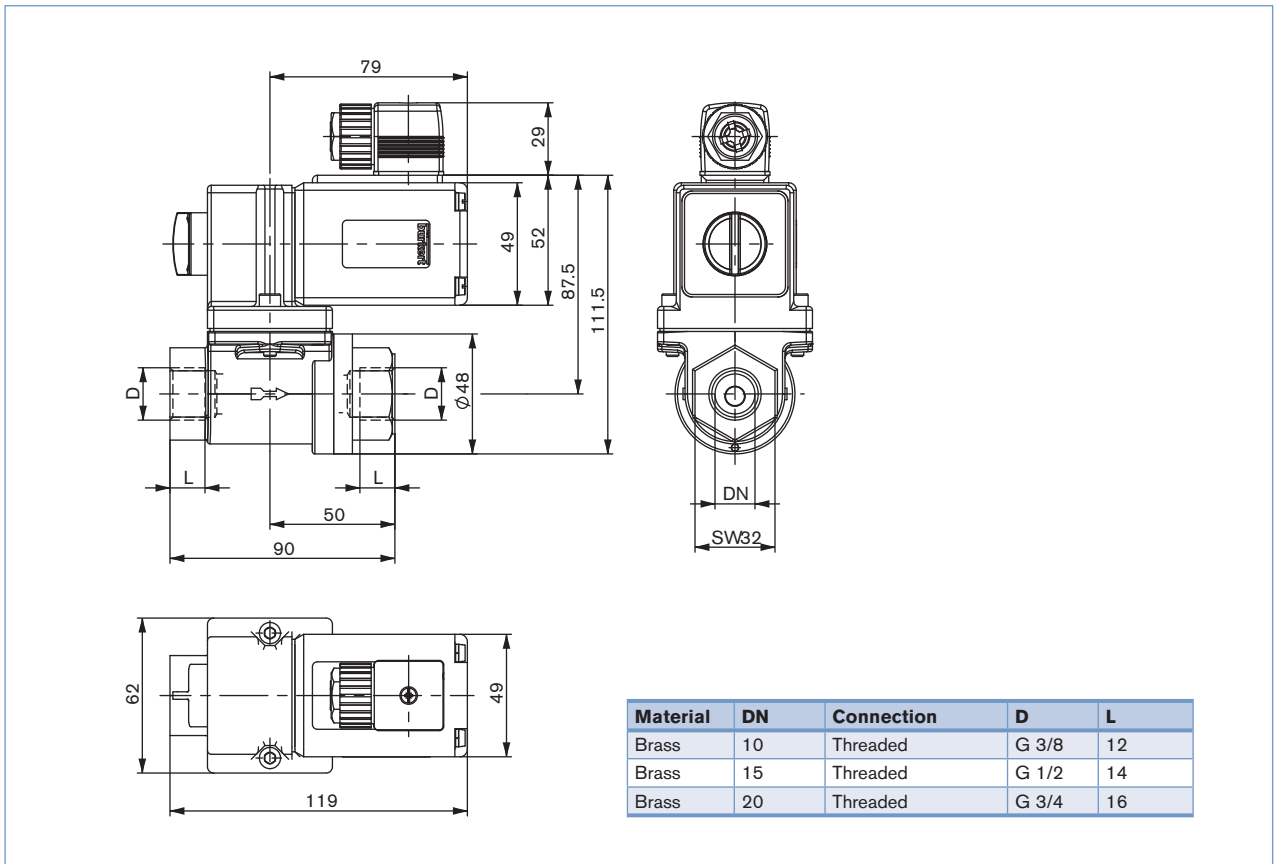

Materials

2/2-way plastic version with true union nut and connection fitting

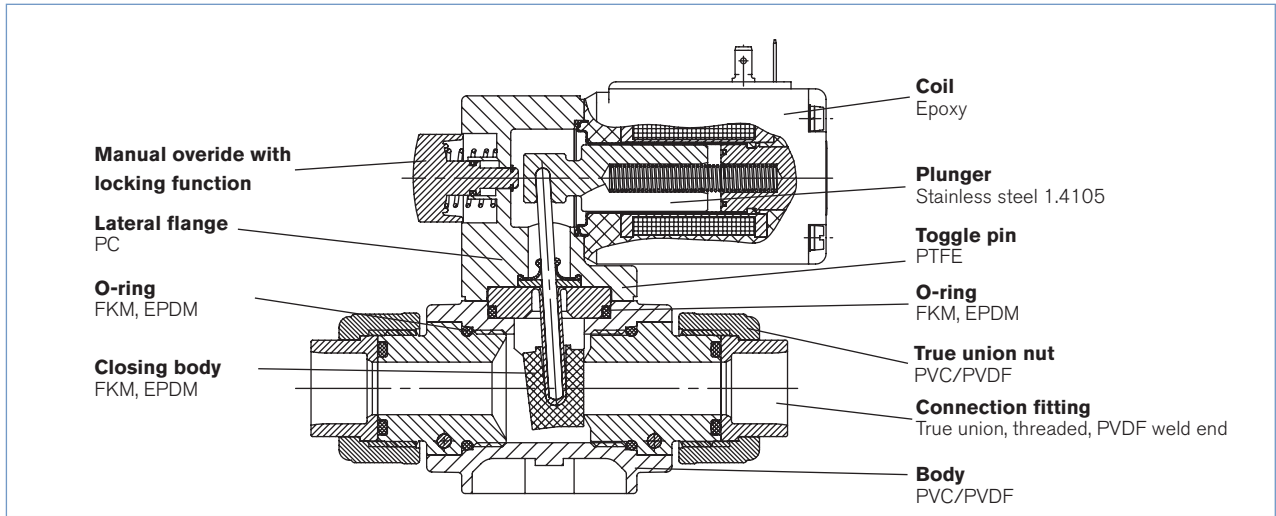

Dimensions [mm]

2/2-way plastic version with true union nut and connection fitting

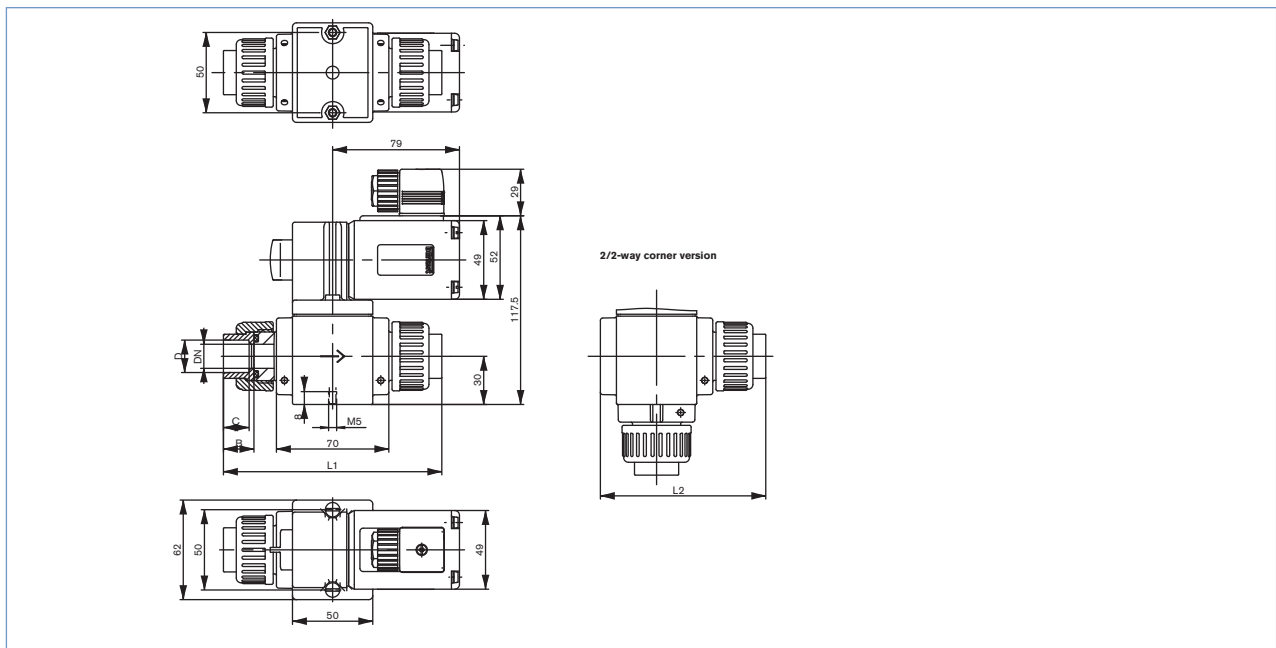

Material	DN	Connection	B	C	D	L 1	L 2
PVC	10	True union	17	14	Ø 16.2	130	99.5
		Threaded	17	12	G 3/8	130	99.5
		Threaded	17	12	NPT 3/8	130	99.5
	10 (with port for DN 15)	True union	19	16	Ø 20.2	134	101.5
		Threaded	19	13	G 1/2	134	101.5
		Threaded	19	14	NPT 1/2	134	101.5
	15	True union	19	16	Ø 20.2	136	103.0
		Threaded	19	13	G 1/2	136	103.0
		Threaded	19	14	NPT 1/2	136	103.0
	15 (with port for DN 20)	True union	22	19	Ø 25.2	142	106.0
		Threaded	22	15	G 3/4	142	106.0
		Threaded	22	16	NPT 3/4	142	106.0
20	True union	22	19	Ø 25.2	144	107.0	
	Threaded	22	15	G 3/4	144	107.0	
	Threaded	22	16	NPT 3/4	144	107.0	
PVDF	10	Weld end	18	15	Ø 15.5	132	100.5
	15	Weld end	19	16	Ø 19.35	136	103.0
	20	Weld end	21	18	Ø 24.5	142	106.0

Ordering chart for valves

2/2-way version, seal material EPDM

Body material	Circuit function	Orifice [mm]	Port connection [inch resp. mm]	Kv value water [m ³ /h]	Pressure range [bar]	Item no. per voltage / frequency					
						24 V/UC	230 V/UC	24 V/50 Hz	230 V/50 Hz		
PVC	A	10	G 3/8	2.0	0-3	058 900	x	x	056 512		
			G 1/2	2.0	0-3	023 759	x	x	056 795		
			True union Ø 16	2.0	0-3	046 949	264 450	x	050 549		
		15	True union Ø 20	2.0	0-3	x	x	x	056 791		
			G 1/2	4.5	0-1	067 832	x	x	054 831		
			True union Ø 20	4.5	0-1	050 809	168 193	051 028	055 423		
	20	True union Ø 25	4.5	0-1	x	x	x	x			
		G 3/4	6.0	0-0.5	049 222	x	x	056 797			
		True union Ø 25	6.0	0-0.5	045 225	x	053 992	051 257			
	B	10	G 3/8	2.0	0-3	x	x	-	-		
			G 1/2	2.0	0-3	x	x	-	-		
			True union Ø 16	2.0	0-3	041 272	x	-	-		
			True union Ø 20	2.0	0-3	x	x	-	-		
		15	G 1/2	4.5	0-1	x	x	-	-		
			True union Ø 20	4.5	0-1	x	x	-	-		
			True union Ø 25	4.5	0-1	x	x	-	-		
			G 3/4	6.0	0-0.5	x	x	-	-		
		20	True union Ø 25	6.0	0-0.5	x	051 748	-	-		
G 3/4			6.0	0-0.5	x	x	-	-			
True union Ø 25			6.0	0-0.5	x	051 748	-	-			
G 3/4			6.0	0-0.5	x	x	-	-			
PVDF	A	10	Weld end Ø 16	2.0	0-3	131 273	274 340	x	x		
		15	Weld end Ø 20	4.5	0-1	x	x	x	197 985		
		20	Weld end Ø 25	6.0	0-0.5	x	x	x	x		
	B	15	Weld end Ø 20	4.5	0-1	x	x	-	-		
		Brass	A	10	G 3/8	2.0	0-3	x	x	x	x
				15	G 1/2	4.5	0-1	x	x	x	056 281
20	G 3/4	6.0		0-0.5	x	x	x	x			
B	10	G 3/8	2.0	0-2	x	x	x	x			
	15	G 1/2	4.5	0-1	049 793	x	x	x			
	20	G 3/4	6.0	0-0.5	x	x	x	x			

2/2-way version, seal material NBR

Body material	Circuit function	Orifice [mm]	Port connection [inch resp. mm]	Kv value water [m ³ /h]	Pressure range [bar]	Item no. per voltage / frequency			
						24 V/UC	230 V/UC	24 V/50 Hz	230 V/50 Hz
Brass	A	10	G 3/8	2.0	0-3	057 475	x	x	053 059
		15	G 1/2	4.5	0-1	054 102	x	x	052 221
		20	G 3/4	6.0	0-0.5	049 751	x	063 602	048 490
	B	10	G 3/8	2.0	0-2	x	051 685	x	x
		15	G 1/2	4.5	0-1	058 371	046 466	x	x
		20	G 3/4	6.0	0-0.5	050 461	053 807	x	x

X on request

- version not possible

Ordering chart for valves

2/2-way version, seal material FKM

Body material	Circuit function	Orifice [mm]	Port connection [inch resp. mm]	Kv value water [m³/h]	Pressure range [bar]	Item no. per voltage / frequency			
						24 V/UC	230 V/UC	24 V/50 Hz	230 V/50 Hz
PVC	A	10	G 3/8	2.0	0-3	x	x	x	x
			G 1/2	2.0	0-3	086 273	x	x	x
			True union Ø 16	2.0	0-3	047 915	x	052 953	050 443
			True union Ø 20	2.0	0-3	056 060	x	055 817	056 789
		15	G 1/2	4.5	0-1	047 398	x	x	056 663
			True union Ø 20	4.5	0-1	053 882	x	051 641	050 787
			True union Ø 25	4.5	0-1	x	x	x	058 369
			20	G 3/4	6.0	0-0.5	x	x	x
	True union Ø 25	6.0		0-0.5	056 495	x	050 551	051 351	
	B	10	G 3/8	2.0	0-3	x	x	-	-
			G 1/2	2.0	0-3	x	x	-	-
			True union Ø 16	2.0	0-3	058 361	053 221	-	-
			True union Ø 20	2.0	0-3	x	x	-	-
		15	G 1/2	4.5	0-1	x	x	-	-
			True union Ø 20	4.5	0-1	047 503	045 439	-	-
			True union Ø 25	4.5	0-1	x	x	-	-
20			G 3/4	6.0	0-0.5	x	x	-	-
	True union Ø 25	6.0	0-0.5	051 969	x	-	-		
PVDF	A	10	Weld end Ø 16	2.0	0-3	78854	x	x	x
		15	Weld end Ø 20	4.5	0-1	x	x	x	130920
		20	Weld end Ø 25	6.0	0-0.5	x	x	x	x
	B	10	Weld end Ø 16	2.0	0-2	x	255332	-	-
		15	Weld end Ø 20	4.5	0-1	x	x	-	-
		20	Weld end Ø 25	6.0	0-0.5	x	x	-	?
Brass	A	10	G 3/8	2.0	0-3	054 053	x	048 664	044 502
		15	G 1/2	4.5	0-1	025 537	x	x	040 549
		20	G 3/4	6.0	0-0.5	069 752	x	x	048 622
	B	10	G 3/8	2.0	0-2	x	x	x	x
		15	G 1/2	4.5	0-1	059 360	046 643	x	x
		20	G 3/4	6.0	0-0.5	x	x	x	x

X on request
- version not possible

To find your nearest Bürkert facility, click on the orange box →

In case of special application conditions,
please consult for advice.

Subject to alterations
© Christian Bürkert GmbH & Co. KG

1502/4_EU-en_00891604

