

2/2-way Solenoid Valve for neutral media and steam



Type 6038 can be combined with...



Type 2508
Cable plug



Type 1078
Timer unit



Type 2511
ASI cable plug



Type 8600
Dosing control

- Piston-operated valve with pressure relief
- Switches without differential pressure
- For neutral media and steam
- Temperatures up to +160 °C
- Fast switching

The Type 6038 valve is a 2/2-way solenoid valve with direct acting switching character, closed by spring force. It is pressure-relieved and switches without differential pressure.

The magnetic core is linked to the seat tube. When the magnetic core is activated, a drilled hole is opened up by a pre-stroke. The core area within the valve is relieved of pressure, and the valve is opened through magnetic force. In the inactive state, the valve is closed by a pressure spring. In doing this, the closing force of the spring is assisted by the pressure of the medium on the magnetic core.

Caution waterhammer danger!

The valves switch very quickly. If liquid media is used with high differential pressures, high pressure peaks (waterhammer) can occur.

Technical data

Orifice	DN 12
Body material	Gunmetal
Valve internals	Stainless steel and brass
Seal material	PTFE
Media	Neutral media, preferably steam
Media temperature	0 to +160 °C
Ambient temperature	Max. +55 °C
Operating voltage	DN 12 24/110/230 V / 50-60 Hz other voltages on request
Voltage tolerance	±10%
Duty cycle	100% continuous rating
Electrical connection	Tag connector sideways acc. DIN EN 175301-803 Form A (for cable plugs Type 2508, see Accessories)
Protection class	IP 65 with cable plug

Technical data

Orifice [mm]	Port connection [inch]	Kv value water (m ³ /h)	Pressure range [bar] ¹⁾	Power consumption		Response times		Weight [kg]
				Inrush [VA]	Hold [VA/W]	Opening [ms]	Closing [ms]	
12	G 3/8, G 1/2	2.2	0-10	106	38/18	20	60	0.9

- Kv value [m³/h]: Flow rate value for water, measured at +20 °C, 1 bar¹⁾ Pressure at valve inlet and 1 bar pressure difference
- Response times [ms]: Measures at valve outlet at 6 bar¹⁾ and +20 °C acc. to ISO 12238
Opening: Pressure build up 0 ... 90 %
Closing: Pressure relief 100 ... 10 %

Materials

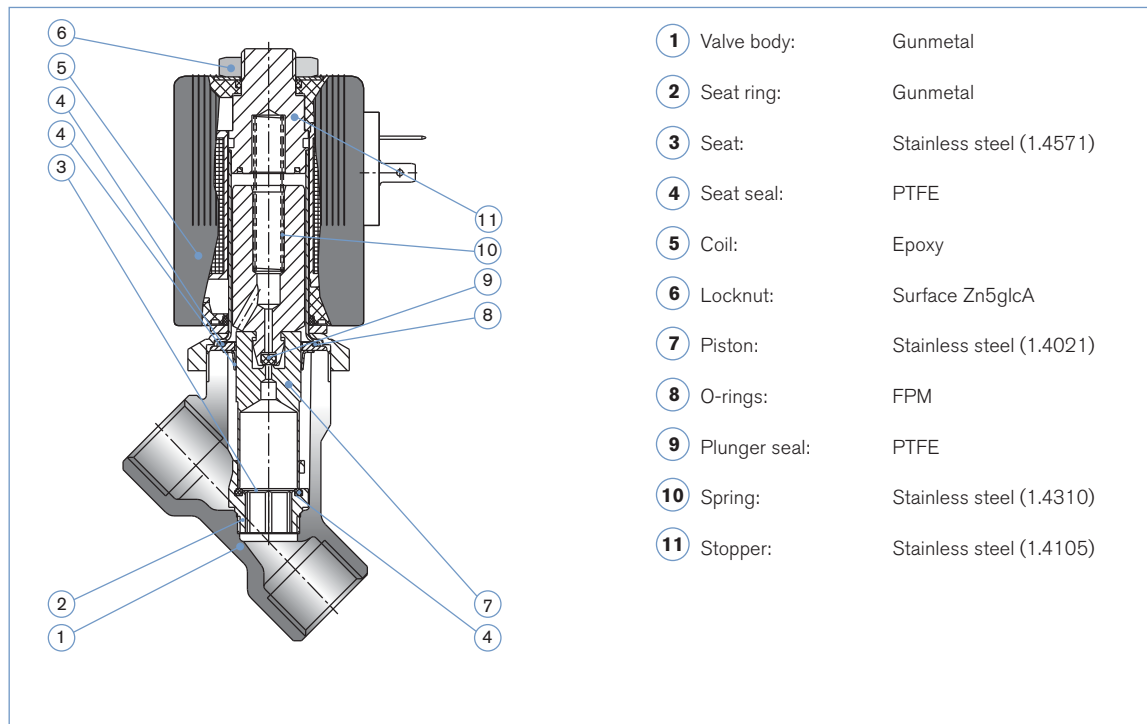

Ordering chart for valves (other versions on request)

All valves with gunmetal body, supplied without cable plug (see Accessories)

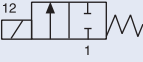
Circuit function	Orifice [mm]	Kv value water [m ³ /h]	Pressure range [bar]	Port connection	Seal material	Voltage/frequency [V/Hz]	Item no.
A 2/2-way valve NC 	12	2.2	0-10	G 3/8	PTFE	024/50-60	140 427
						110/50-60	140 428
						230/50-60	140 429
				G 1/2	PTFE	024/50-60	140 430
						110/50-60	140 431
						230/50-60	140 432

Ordering chart for valves (cable plug Type 2508 acc. DIN EN 175301-803 Form A)

The delivery of a cable plug includes the flat seal and the fixing screw (galvanised and chrome-plated): In the case of stainless steel valves, we recommend a cable plug with a stainless steel screw (see ordering chart, without circuitry)

Circuitry version	Voltage	Item no.
Without circuitry, standard	0-250 V AC/DC	008 376
Without circuitry, SS screw	0-250 V AC/DC	132 445
Without circuitry, silicone seal ¹⁾	0-250 V AC/DC	131 874
With LED	12-24 V AC/DC	008 360
With LED and varistor	12-24 V AC/DC	008 367
With LED	200-240 V AC/DC	008 362
With LED and varistor	200-240 V AC/DC	008 369
Further versions please see Datasheet Type 2508		

¹⁾ Silicone seal for higher temperatures; otherwise NBR flat seal

Cable plug Type 2508

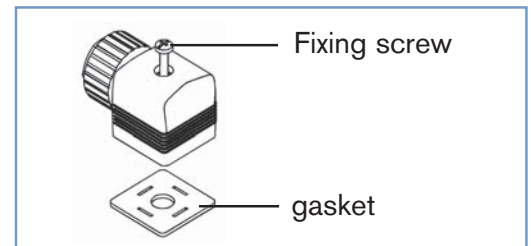

Dimensions [mm]

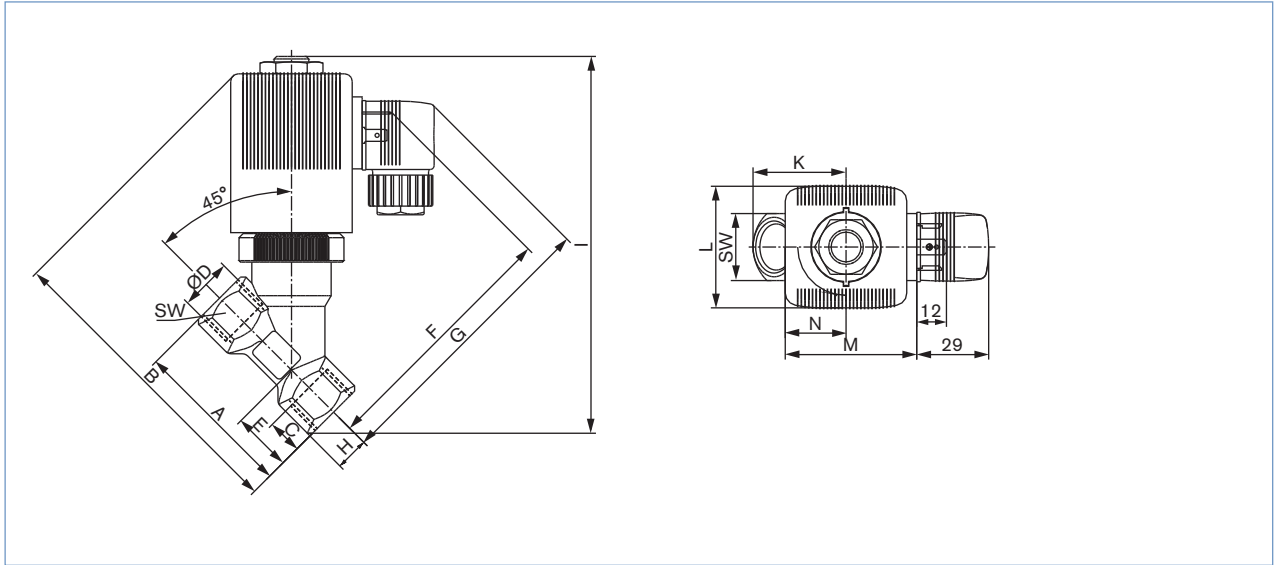

Orifice [mm]	Ø D port conn. [inch]	C thread depth [mm]	A [mm]	B [mm]	E [mm]	F [mm]	G [mm]	H [mm]	I [mm]	K [mm]	L [mm]	M [mm]	N [mm]	SW [mm]
12	G 3/8	12	65	124.5	24	102	116	13.5	152	37.5	49	53	24.5	27
12	G 1/2	14	65	124.5	24	102	116	13.5	152	37.5	49	53	24.5	27

