

По вопросам продаж и поддержки обращайтесь:

Архангельск (8182)63-90-72	Краснодар (861)203-40-90	Рязань (4912)46-61-64
Астана (7172)727-132	Красноярск (391)204-63-61	Самара (846)206-03-16
Белгород (4722)40-23-64	Курск (4712)77-13-04	Санкт-Петербург (812)309-46-40
Брянск (4832)59-03-52	Липецк (4742)52-20-81	Саратов (845)249-38-78
Владивосток (423)249-28-31	Магнитогорск (3519)55-03-13	Смоленск (4812)29-41-54
Волгоград (844)278-03-48	Москва (495)268-04-70	Сочи (862)225-72-31
Вологда (8172)26-41-59	Мурманск (8152)59-64-93	Ставрополь (8652)20-65-13
Воронеж (473)204-51-73	Набережные Челны (8552)20-53-41	Тверь (4822)63-31-35
Екатеринбург (343)384-55-89	Нижний Новгород (831)429-08-12	Томск (3822)98-41-53
Иваново (4932)77-34-06	Новокузнецк (3843)20-46-81	Тула (4872)74-02-29
Ижевск (3412)26-03-58	Новосибирск (383)227-86-73	Тюмень (3452)66-21-18
Казань (843)206-01-48	Орел (4862)44-53-42	Ульяновск (8422)24-23-59
Калининград (4012)72-03-81	Оренбург (3532)37-68-04	Уфа (347)229-48-12
Калуга (4842)92-23-67	Пенза (8412)22-31-16	Челябинск (351)202-03-61
Кемерово (3842)65-04-62	Пермь (342)205-81-47	Череповец (8202)49-02-64
Киров (8332)68-02-04	Ростов-на-Дону (863)308-18-15	Ярославль (4852)69-52-93

Единый адрес: btk@nt-rt.ru **Веб-сайт:** www.burkert.nt-rt.ru

ЭЛЕКТРОМАГНИТНЫЕ КЛАПАНЫ



Piston valve, 3/2-way, servo-assisted

- Servo-assisted piston valve from DN8 to DN40
- Increased operational safety with pivoted armature technology
- Service-friendly manual override
- Energy-saving “Kick and Drop” or pulse coils
- Explosion-proof variants available on request

Product variants described in the data sheet may differ from the product presentation and description.

Can be combined with

	Type 2518 Cable Plug DIN EN 175301-803 - Form A	▶
	Type 2516 Cable plug DIN EN 175301-803 - connector shape C	▶
	Type 1087 Timer	▶

Type description

The valve 6430 is a servo-assisted 3/2-way piston valve. If the valve is not supplied with auxiliary pilot air, a minimum differential pressure is required for the function.

Variants:

- For neutral liquids and gases in the pressure range 1-16 bar in the function NC and NO.
 - For technical vacuums up to 3 bar in the function NC and NO.
 - With auxiliary pilot air for vacuums up to 8 bar in the function NC and NO.
- All variants are available as an impulse version to secure the switching position even in the event of power interruptions. The Type 6430 is equipped with a manual override for start-up or manual operation (exception: impulse version).

To reduce electrical power consumption during operation, coils with integrated “Kick and Drop” (KD) electronics featuring double coil technology are available. A maintenance-free, media-separated 3/2-way pivoted armature valve Type 0331 is used as a pilot valve. In combination with a plug to DIN EN 175301 – 803 Form A, the valves satisfy degree of protection IP65.

1. General technical data

Product properties	
Material	
Body	Brass (DN8...DN20), gunmetal (DN25...DN40)
Coil	Epoxy
Seal	NBR, PUR, FKM, EPDM (on request)
Orifice	DN8, DN12, DN20, DN25, DN40
(Thermal) Insulation class for coil	H
Electrical data	
Voltage tolerance	± 10 %
Duty cycle	Continuous rating 100 % ED (Unless otherwise specified on the type plate)
Protection class	IP65 with cable plug, cable connection or junction box
Power consumption	
Standard version, vacuum version and external air controlled version	Inrush AC: 30 VA Hold AC: 15 VA/8 W DC cold/warm: 11 W/8 W
Vacuum version Low-Power	DC cold/warm: 3.4 W/2 W
Impulse version	Hold AC: 20 VA/11 W DC cold/warm: 11 W/8 W
Explosion-proof version	Inrush/Hold: 40 W/3 W
Performance data	
Response times¹⁾	
DN8	Opening: 25 ms Closing: 30 ms
DN12	Opening: 30 ms Closing: 60 ms
DN20	Opening: 35 ms Closing: 270 ms
DN25	Opening: 50 ms Closing: 300 ms
DN40	Opening: 80 ms Closing: 740 ms
Medium data	
Medium²⁾	
Standard version	Neutral media such as compressed air, water, low-viscosity oils Oil- and grease-free media with EPDM
Vacuum version and external air controlled version	Neutral gases, compressed air, vacuum (low vacuum)
Medium temperature	
NBR	0 °C...+80 °C
PUR	0 °C...+80 °C
FKM	0 °C...+90 °C
EPDM	0 °C...+90 °C
Viscosity	Max. 21 mm ² /s
Approvals and certificates	
Ignition protection type (ATEX and IECEx)	
with cable	II 2G Ex mb IIC T4 Gb II 2D Ex mb IIIC T130 °C Db
with terminal box	II 2G Ex eb mb IIC T4 Gb II 2D Ex mb tb IIIC T130 °C Db
Product connections	
Port connection	G ¼, G ½, G ¾, G 1, G 1½ (NPT on request)
Electrical connection	
Standard version, vacuum version and external air controlled version	Tag connector acc. to DIN EN 175 301 - 803 Form A for cable plug Type 2518
Vacuum version Low-Power	Tag connector acc. to DIN EN 175 301 - 803 Form C for cable plug Type 2516
Explosion-proof version	With cable outlet 3 x 0.5 mm ² or terminal box

Environment and installation

Installation position	As required, preferably with actuator upright
Ambient temperature	0 °C...+55 °C -20 °C...+55 °C (EPDM)

Accessories

Cable plug	Type 2518, see “Cable plug Type 2518, Form A according to DIN EN 175301 -803” on page 18 Type 2516, see “Cable plug Type 2516, Form C according to DIN EN 175301 -803” on page 18
------------	--

- 1.) Measured at valve outlet with 6 bar and +20 °C. Opening: pressure build-up 0...90 %, closing: pressure reduction 100...10 %
2.) Media resistance according to the material combination

2. Circuit functions

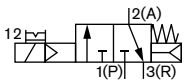
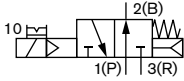
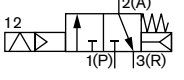
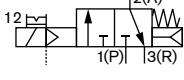
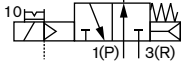
Circuit functions	Description
	Type: C, solenoid valve 3/2 way Servo-controlled, with manual mode Normally closed
	Type: D, solenoid valve 3/2 way Servo-controlled, with manual mode Normally open
	Type: C, Impuls-solenoid valve 3/2 way Servo-controlled Normally closed
	Type: C, solenoid valve 3/2 way Servo-controlled, with auxiliary pilot air, with manual mode Normally closed
	Type: D, solenoid valve 3/2 way Servo-controlled, with auxiliary pilot air, with manual mode Normally open

3. Materials

3.1. Chemical Resistance Chart – Bürkert resistApp



Bürkert resistApp – Chemical Resistance Chart

You want to ensure the reliability and durability of the materials in your individual application case? Verify your combination of media and materials on our website or in our resistApp.

[Start Chemical Resistance Check](#)

3.2. Material specifications

Standard and vacuum version

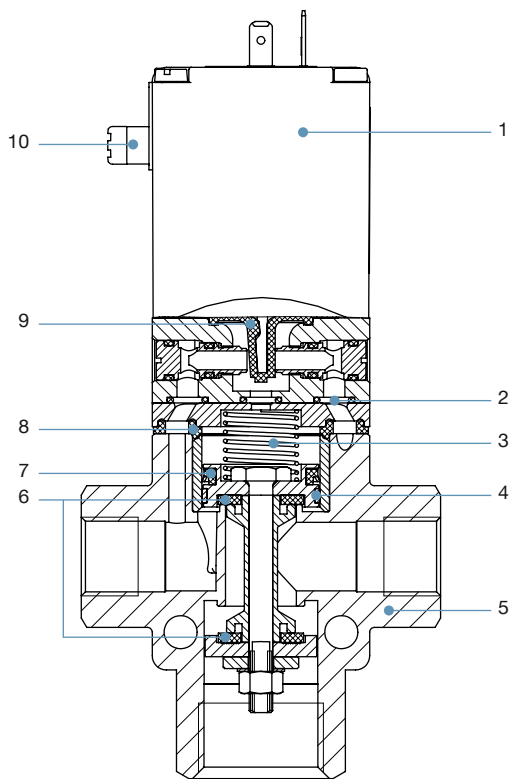

No.	Element	Material
1	Coil	Epoxy
2	O-rings	NBR, FKM, EPDM
3	Spring ^{1.)}	1.4310 stainless steel
4	Piston ring	PTFE
5	Housing	Brass, Gunmetal
6	Seat seal	NBR, PUR, FKM, EPDM
7	Piston seal	NBR, FKM, EPDM
8	Seal	NBR, FKM, EPDM
9	Diaphragm	NBR, FKM, EPDM
10	Manual override	PA

1.) Only for the vacuum version.

External air controlled version

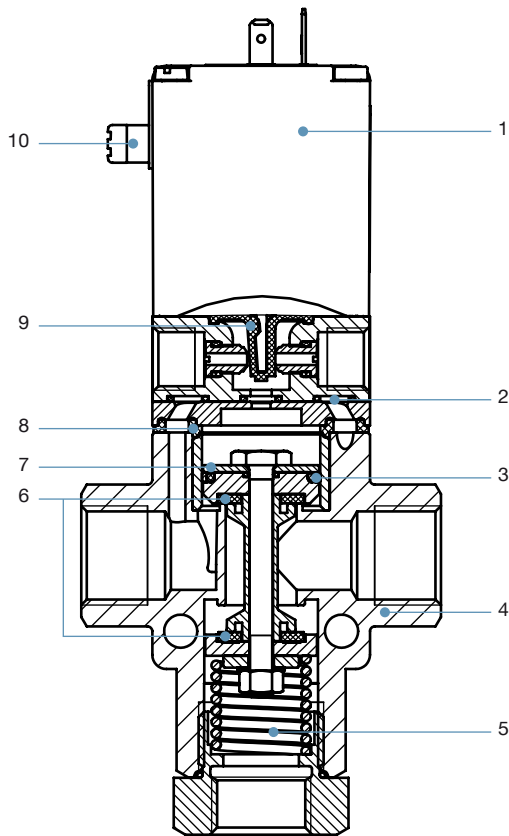

No.	Element	Material
1	Coil	Epoxy
2	O-rings	NBR, FKM, EPDM
3	Piston ring	PTFE
4	Housing	Brass, Gunmetal
5	Spring	1.4310 stainless steel
6	Seat seal	NBR, PUR, FKM, EPDM
7	Piston seal	NBR, FKM, EPDM
8	Seal	NBR, FKM, EPDM
9	Diaphragm	NBR, FKM, EPDM
10	Manual override	PA

4. Dimensions

4.1. Standard and vacuum version

Note:

- Dimensions in mm
- The dimensions A1, B1, E1 and F1 apply to G threads.
- The dimensions A2, B2, E2 and F2 apply to NPT threads.
- The figure shows the valve in circuit function C with ports P, R and A/B (manual override via port P).
In circuit function D, the manual override is located above port A/B.

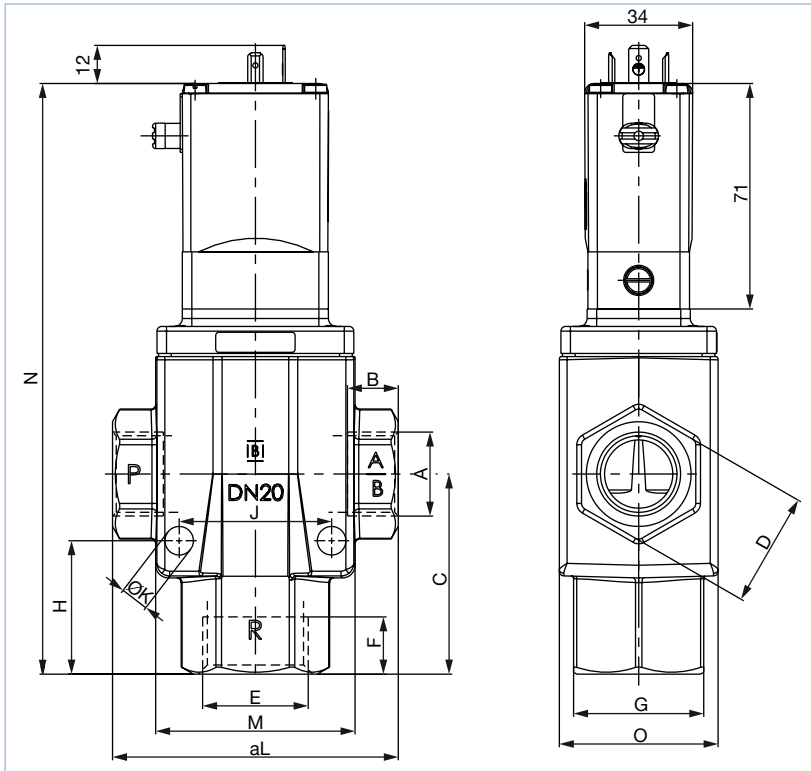

DN	A1	B1	A2	B2	C	D	E1	F1	E2	F2	G	H	J	K	L	M	N	O
8	G ¼	12	NPT ¼	10	34.5	SW22	G ¾	12	NPT ¾	10.3	SW22	23	30	7	65	46	124.8	33
12	G ½	14	NPT ½	13.7	47	SW27	G ¾	16	NPT ¾	14	SW32	31	34	7	76	46	150.5	33
20	G ¾	16	NPT ¾	14	63	SW36	G 1	18	NPT 1	16.8	SW41	42	48	9	90	63	186	50
25	G 1	18	NPT 1	16.8	74.5	SW41	G 1¼	20	NPT 1¼	17.3	54	44	66	9	110	82	210.5	60
40	G 1½	22.5	NPT 1½	17.3	104	SW55	G 2	26.5	NPT 2	17.6	78	65	93	13	153	117	264	88

Pilot valve configuration

Type 6430 WWC | Type 6430 WWD

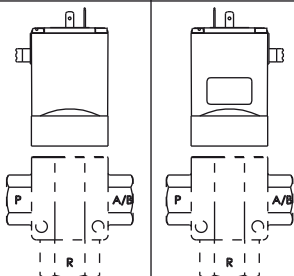

4.2. Vacuum version Low-Power

Note:

- Dimensions in mm
- The dimensions A1, B1, E1 and F1 apply to G threads.
- The dimensions A2, B2, E2 and F2 apply to NPT threads.
- The figure shows the valve in circuit function C with ports P, R and A/B (manual override via port P). In circuit function D, the manual override is located above port A/B.

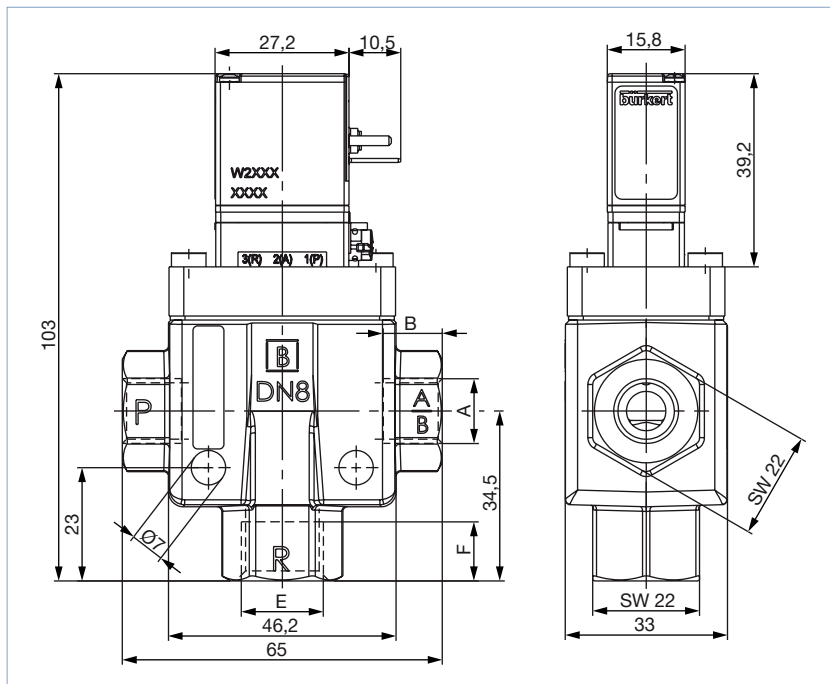

DN	A1	B1	A2	B2	E1	F1	E2	F2
8	G 1/4	12	NPT 1/4	10	G 3/8	12	NPT 3/8	10.3

Pilot valve configuration

Type 6430 WWC | Type 6430 WWD

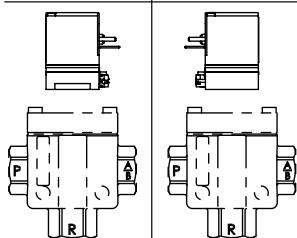

DTS 1000395477 EN Version: B Status: RL (released | freigegeben | validé) printed: 20.11.2019

4.3. External air controlled version

Note:

- Dimensions in mm
- The dimensions A1, B1, E1 and F1 apply to G threads.
- The dimensions A2, B2, E2 and F2 apply to NPT threads.
- The figure shows the valve in circuit function C with ports P, R and A/B (manual override via port P). In circuit function D, the manual override is located above port A/B.

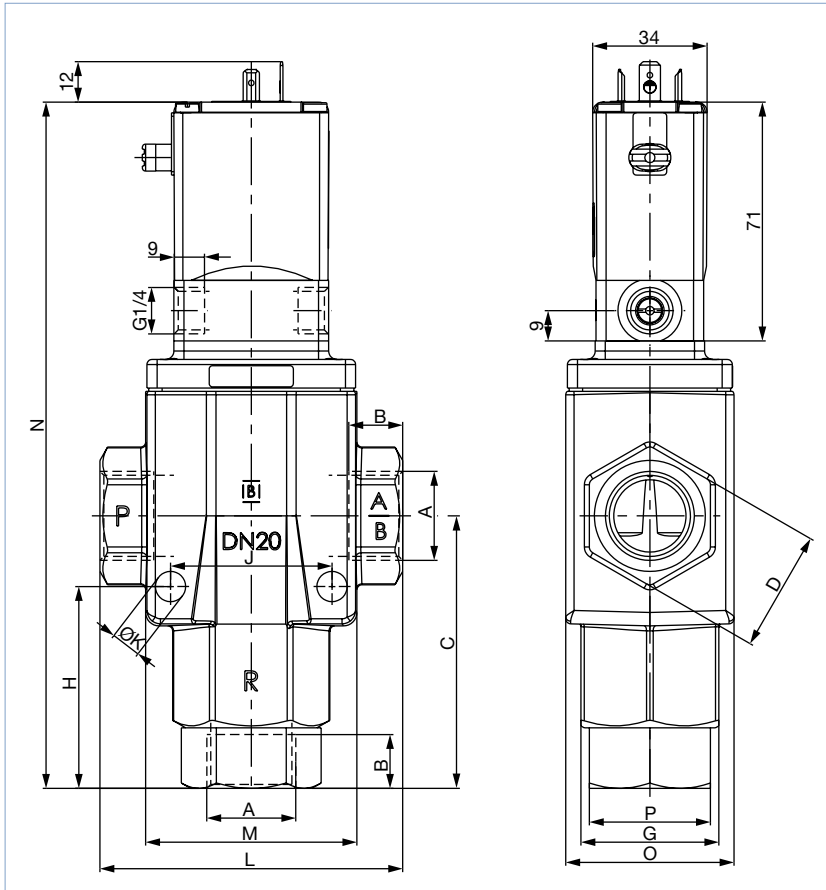

DN	A1	B1	A2	B2	C	D	G	H	J	K	L	M	N	O	P
8	G 1/4	12	NPT 1/4	10	47.5	SW22	SW22	36	30	7	65	46	137.8	33	SW19
12	G 1/2	14	NPT 1/2	13.7	59	SW27	SW32	43	34	7	76	46	162.5	33	SW32
20	G 3/4	16	NPT 3/4	14	81	SW36	SW41	60	48	9	90	63	204	50	SW36

Pilot valve configuration

Type 6430 WWC | Type 6430 WWD

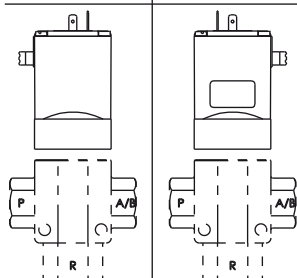

DTS 1000395477 EN Version: B Status: RL (released | freigegeben | valide) printed: 20.11.2019

4.4. ATEX/IECEX version

Note:

- Dimensions in mm
- The dimensions A1, B1, E1 and F1 apply to G threads.
- The dimensions A2, B2, E2 and F2 apply to NPT threads.

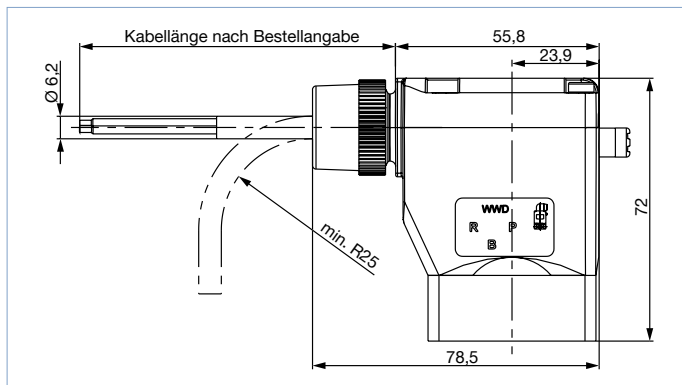
Version with cable outlet

Versions with junction box

Note:

The figure shows the valve in circuit function C with ports P, R and A/B (manual override via port P).
In circuit function D, the manual override is located above port A/B.

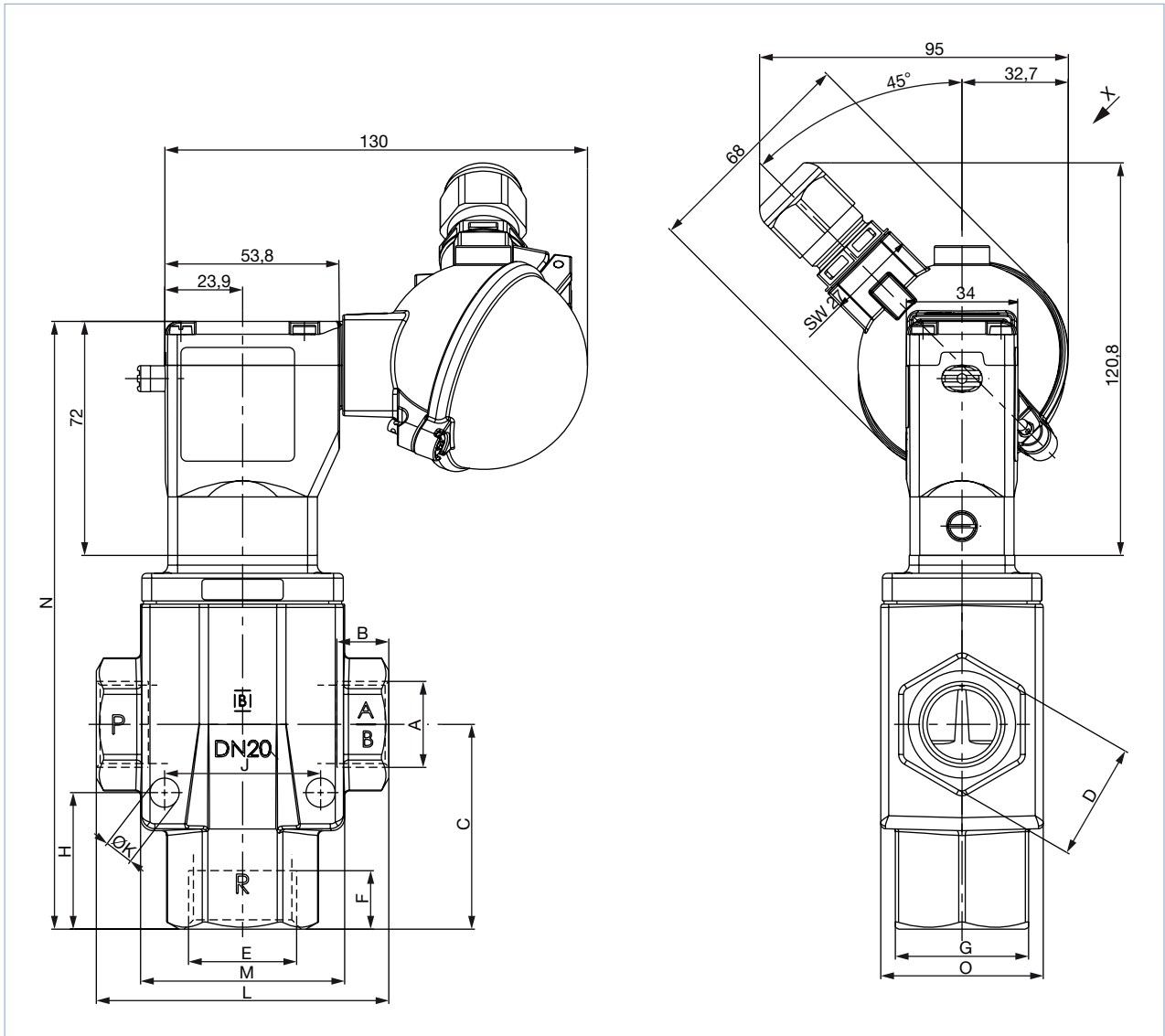

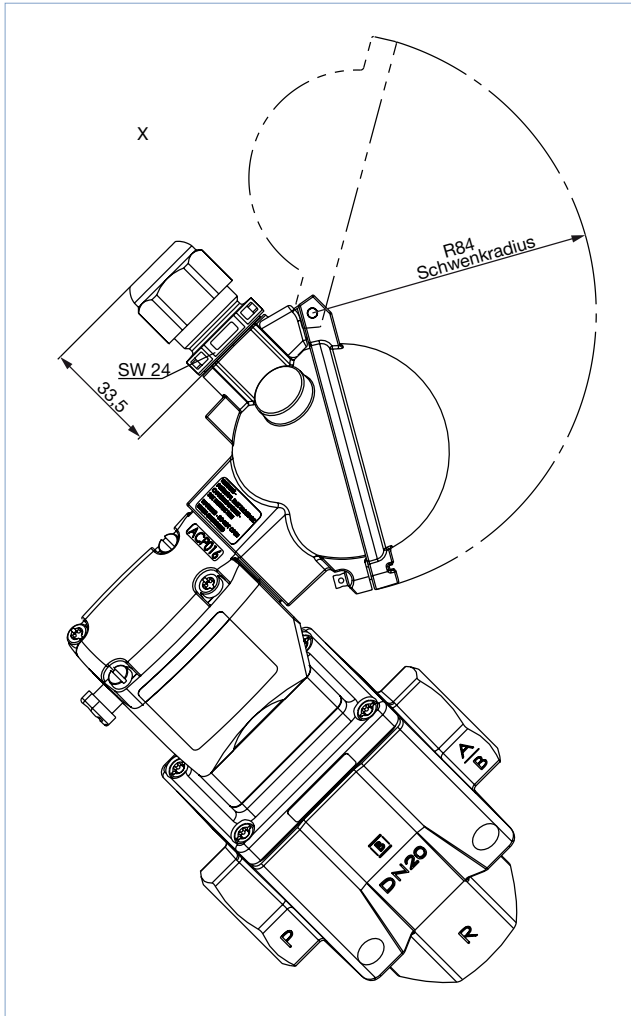

DN	A1	B1	A2	B2	C	D	E1	F1	E2	F2	G	H	J	K	L	M	N	O
8	G ¼	12	NPT ¼	10	34.5	SW22	G ⅝	12	NPT ⅝	10.3	SW22	23	30	7	65	46	124.8	33
12	G ½	14	NPT ½	13.7	47	SW27	G ¾	16	NPT ¾	14	SW32	31	34	7	76	46	150.5	33
20	G ¾	16	NPT ¾	14	63	SW36	G 1	18	NPT 1	16.8	SW41	42	48	9	90	63	186	50
25	G 1	18	NPT 1	16.8	74.5	SW41	G 1¼	20	NPT 1¼	17.3	54	44	66	9	110	82	210.5	60
40	G 1½	22.5	NPT 1½	17.3	104	SW55	G 2	26.5	NPT 2	17.6	78	65	93	13	153	117	264	88

Pilot valve configuration

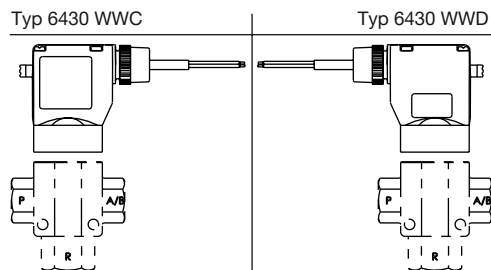

DTS 1000395477 EN Version: B Status: RL (released | freigegeben | validé) printed: 20.11.2019

5. Ordering information

5.1. Bürkert eShop – Easy ordering and quick delivery



Bürkert eShop – Easy ordering and fast delivery

You want to find your desired Bürkert product or spare part quickly and order directly? Our online shop is available for you 24/7. Sign up and enjoy all the benefits.

[Order online now](#)

5.2. Bürkert product filter



Bürkert product filter – Get quickly to the right product

You want to select products comfortably based on your technical requirements? Use the Bürkert product filter and find suitable articles for your application quickly and easily.

[Try out our product filter](#)

5.3. Ordering chart

Standard version

Note:

- Please note that the cable plug has to be ordered separately, see separate data sheet **Type 2518** ► or ordering chart accessories **“Cable plug Type 2518, Form A according to DIN EN 175301 - 803” on page 18.**
- Further versions are available on request.
- Valid for all articles in the following table: Housing material brass (DN25 and DN40 Gunmetal)

Circuit function	Port connection P and A/B	Orifice	K _v value water	Pressure range	Weight	Article no. acc. to voltage/frequency [V/Hz]		
		[mm]	[m ³ /h] ^{1,)}	[bar] ^{2,)}	[kg]	024/DC	024/50	230/50
G-inner thread, seal material NBR (DN12 seat seal PUR / external sealing NBR)								
C, solenoid valve 3/2 way Servo-controlled, with manual mode Normally closed	G ¼	8	0.95	1...16	0.9	351164	357602	357604
	G ½	12	2.6	1...16	1.1	351175	357609	357611
	G ¾	20	6.2	1...16	2.2	351235	357615	357617
	G 1	25	10.0	1...10	2.8	351241	357621	357622
	G 1 ½	40	22.8	1...10	6.1	351247	357623	357624

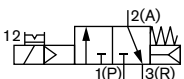

DTS 1000395477 EN Version: B Status: RL (released | freigegeben | valide) printed: 20.11.2019

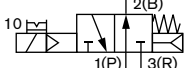
Circuit function	Port connection P and A/B	Orifice	K _v value water	Pressure range	Weight	Article no. acc. to voltage/frequency [V/Hz]		
		[mm]	[m ³ /h] ^{1.)}	[bar] ^{2.)}	[kg]	024/DC	024/50	230/50
G-inner thread, seal material NBR (DN12 seat seal PUR / external sealing NBR)								
D, solenoid valve 3/2 way Servo-controlled, with manual mode normally open 	G ¼	8	0.95	1...16	0.9	357601 ☒	357603 ☒	357605 ☒
	G ½	12	2.6	1...16	1.1	357608 ☒	357610 ☒	357612 ☒
	G ¾	20	6.2	1...16	2.2	357614 ☒	357616 ☒	357618 ☒
	G 1	25	10.0	1...10	2.8	357619 ☒	X	364298 ☒
	G 1 ½	40	22.8	1...10	6.1	364302 ☒	X	364299 ☒

1.) Measured at +20 °C, 1 bar pressure at valve inlet and free outlet

2.) Pressure data: Overpressure with respect to atmospheric pressure

X: on request

Standard version as impulse valve

Note:

Valid for all articles in the following table: Housing material brass (DN25 and DN40 Gunmetal)

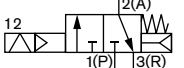
Circuit function	Port connection P and A/B	Orifice	K _v value water	Pressure range	Weight	Article no. acc. to voltage/frequency [V/Hz]	
		[mm]	[m ³ /h] ^{1.)}	[bar] ^{2.)}	[kg]	024/DC	024/50
G-inner thread, seal material NBR (DN12 seat seal PUR / external seal NBR)							
C, Impuls-solenoid valve 3/2 way Servo-controlled Normally closed without manual mode 	G ¼	8	0.95	1...16	0.9	357606 ☒	X
	G ½	12	2.6	1...16	1.1	357613 ☒	X
	G ¾	20	6.2	1...16	2.2	X	X
	G 1	25	10.0	1...10	2.8	X	X
	G 1 ½	40	22.8	1...10	6.1	X	X

1.) Measured at +20 °C, 1 bar pressure at valve inlet and free outlet

2.) Pressure data: Overpressure with respect to atmospheric pressure

X: on request

Vacuum version

Note:

- Please note that the cable plug has to be ordered separately, see separate data sheet **Type 2518** ► or ordering chart accessories "**Cable plug Type 2518, Form A according to DIN EN 175301-803**" on page 18.
- Please note that the vacuum version requires a minimum pressure difference of 0.5 bar and is only suitable for low vacuum (atmospheric pressure (1013 hPa) to 100 Pa (1 mbar)).
- Further versions are available on request.
- Valid for all articles in the following table: Housing material brass (DN25 and DN40 Gunmetal)

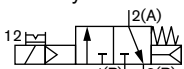
Circuit function	Port connection P and A/B	Orifice	K _v value water	Pressure range	Weight	Article no. acc. to voltage/frequency [V/Hz]	
		[mm]	[m ³ /h] ^{1.)}	[bar] ^{2.)} , ^{3.)}	[kg]	024/DC	024/50
G-inner thread, seal material NBR							
C, solenoid valve 3/2 way Servo-controlled, with manual mode Normally closed 	G ¼	8	0.95	Vacuum up to 3	0.9	351169 ☒	357628 ☒
	G ½	12	2.6	Vacuum up to 3	1.1	351179 ☒	357631 ☒
	G ¾	20	6.2	Vacuum up to 3	2.2	351237 ☒	357634 ☒
	G 1	25	10.0	Vacuum up to 3	2.8	351243 ☒	357637 ☒
	G 1 ½	40	22.8	Vacuum up to 3	6.1	351249 ☒	X

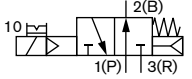
Circuit function	Port connection P and A/B	Orifice	K _v value water	Pressure range	Weight	Article no. acc. to voltage/frequency [V/Hz]	
		[mm]	[m ³ /h] ^{1.)}	[bar] ^{2.)3.)}	[kg]	024/DC	024/50
G-inner thread, seal material NBR							
D, solenoid valve 3/2 way Servo-controlled, with manual mode Normally open 	G ¼	8	0.95	Vacuum up to 3	0.9	357627 ☹	357629 ☹
	G ½	12	2.6	Vacuum up to 3	1.1	357630 ☹	357632 ☹
	G ¾	20	6.2	Vacuum up to 3	2.2	357633 ☹	357635 ☹
	G 1	25	10.0	Vacuum up to 3	2.8	357636 ☹	357638 ☹
	G 1 ½	40	22.8	Vacuum up to 3	6.1	X	X

1.) Measured at +20 °C, 1 bar pressure at valve inlet and free outlet

2.) Pressure data: Overpressure with respect to atmospheric pressure

3.) For switching a minimum pressure difference of 0.5 bar is required

X: on request

Vacuum version as impulse valve

Note:

Valid for all articles in the following table: Housing material brass (DN25 and DN40 Gunmetal)

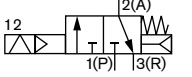
Circuit function	Port connection P and A/B	Orifice	K _v value water	Pressure range	Weight	Article no. acc. to voltage/frequency [V/Hz]	
		[mm]	[m ³ /h] ^{1.)}	[bar] ^{2.)3.)}	[kg]	024/DC	024/50
G-inner thread, seal material NBR							
C, Impuls-solenoid valve 3/2 way Servo-controlled, without manual mode Normally closed 	G ¼	8	0.95	Vacuum up to 3	0.9	357639 ☹	X
	G ½	12	2.6	Vacuum up to 3	1.1	357640 ☹	X
	G ¾	20	6.2	Vacuum up to 3	2.2	357641 ☹	X
	G 1	25	10.0	Vacuum up to 3	2.8	357642 ☹	X
	G 1 ½	40	22.8	Vacuum up to 3	6.1	357643 ☹	X

1.) Measured at +20 °C, 1 bar pressure at valve inlet and free outlet

2.) Pressure data: Overpressure with respect to atmospheric pressure

3.) For switching a minimum pressure difference of 0.5 bar is required

X: on request

Vacuum version Low-Power

Note:

- Please note that the cable plug has to be ordered separately, see separate data sheet **Type 2516** ▶ or ordering chart accessories “Cable plug Type 2516, Form C according to DIN EN 175301-803” on page 18.
- Please note that the vacuum version requires a minimum pressure difference of 0.5 bar and is only suitable for low vacuum (atmospheric pressure (1013 hPa) to 100 Pa (1 mbar)).
- Further versions are available on request.
- Valid for all articles in the following table: Housing material brass (DN25 and DN40 Gunmetal)

Circuit function	Port connection P and A/B	Orifice	K _v value water	Pressure range	Weight	Article no. acc. to voltage/frequency [V/Hz]
		[mm]	[m ³ /h] ^{1.)}	[bar] ^{2.)3.)}	[kg]	024/DC
G-inner thread, seal material NBR						
C, solenoid valve 3/2 way Servo-controlled, with manual mode Normally closed	G ¼	8	0.95	Vacuum up to 1	0.6	357626
D, solenoid valve 3/2 way Servo-controlled, with manual mode Normally open	G ¼	8	0.95	Vacuum up to 1	0.6	357625

1.) Measured at +20 °C, 1 bar pressure at valve inlet and free outlet

2.) Pressure data: Overpressure with respect to atmospheric pressure

3.) For switching a minimum pressure difference of 0.5 bar is required

5.4. External air controlled version

Note

- Please note that the cable plug has to be ordered separately, see separate data sheet **Type 2518** ▶.
- Please note that the version controlled by external air requires an auxiliary control air of at least 2 bar above the operating pressure.
- Further versions are available on request.
- Valid for all articles in the following table: Housing material brass (DN25 and DN40 Gunmetal)

Circuit function	Port connection P and A/B	Orifice	K _v value water	Pressure range	Weight	Article no. acc. to voltage/frequency [V/Hz]
		[mm]	[m ³ /h] ^{1.)}	[bar] ^{2.)3.)}	[kg]	024/DC
G-inner thread, seal material NBR (DN8 and DN12 seat seal PUR / external seal NBR)						
C, solenoid valve 3/2 way Servogesteuert Normally closed mit Steuerhilfsluft mit Handbetätigung	G ¼	8	0.95	Vacuum up to 8	0.9	351172
	G ½	12	2.6	Vacuum up to 8	1.1	351181
	G ¾	20	6.2	Vacuum up to 8	2.3	351239

Circuit function	Port connection P and A/B	Orifice	K _v value water	Pressure range	Weight	Article no. acc. to voltage/ frequency [V/Hz]
		[mm]	[m ³ /h] ^{1.)}	[bar] ^{2.)3.)}	[kg]	024/DC
G-inner thread, seal material NBR (DN8 and DN12 seat seal PUR / external seal NBR)						
D, solenoid valve 3/2 way Servogesteuert Stromlos geöffnet mit Steuerhilfsluft mit Handbetätigung	G ¼	8	0.95	Vacuum up to 8	0.9	357644
	G ½	12	2.6	Vacuum up to 8	1.1	357645
	G ¾	20	6.2	Vacuum up to 8	2.3	357646

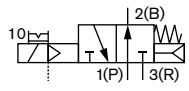

3.) The version controlled by external air requires an auxiliary control air of at least 2 bar above the operating pressure.

1.) Measured at +20 °C, 1 bar pressure at valve inlet and free outlet

2.) Pressure data: Overpressure with respect to atmospheric pressure

3.) For switching a minimum pressure difference of 0.5 bar is required

Further versions on request	
Additional Electrical position feedback	Material <ul style="list-style-type: none"> • FKM • EPDM
Approval <ul style="list-style-type: none"> • cURus – coil approval • Pilot valve cURus (UL-recognized) – approval • ATEX/IECEx – approval 	Voltage Further voltages on request
Process connection NPT	

DTS 1000395477 EN Version: B Status: RL (released | freigegeben | valide) printed: 20.11.2019

5.5. Ordering chart accessories

Cable plug Type 2518, Form A according to DIN EN 175301 - 803

Note:

- The scope of delivery of a cable plug includes a flat gasket and a fixing screw.
- Further versions see data sheet **Type 2518** ▶.

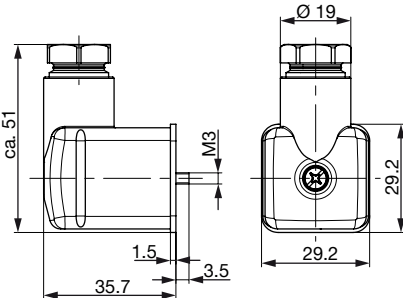
Cable plug	Dimensions	Version	Voltage	Continuous current	Article no.
		Without circuitry (AC/DC)	0...250 V AC/DC	16 A 10 A (VDE, UL) 8 A (CSA)	314802
		Without circuitry, 3 pin and protective conductor (for impulse version)	0...250 V AC/DC	16 A 10 A (VDE)	315329
		With LED (AC/DC)	12...24 V AC/DC	10 A	314812
		With LED and varistor (AC/DC)	12...24 V AC/DC	10 A	314820
		With rectifier, LED and varistor	12...24 V AC/DC	1 A	314816

Cable plug Type 2516, Form C according to DIN EN 175301 - 803

Note:

- Nur für Vakuumausführung Low-Power
- The scope of delivery of a cable plug includes a flat gasket and a fixing screw.
- Further versions see data sheet **Type 2516** ▶.

Cable plug	Version	Voltage	Continuous current	Article no. without cable
	Without circuitry	0...250 V AC/DC	Max. 6 A	303141

Threaded connection, reduction, cylindrical UNI-ISO 228/1

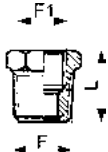
Reduction	Material	Max. nominal pressure [bar]	F	F1	L	Packaging unit	Article no.
					[mm]	[piece]	
	brass, nickel-plated	60	G ½	G ¾	15.5	10	780140

DTS 1000395477 EN Version: B Status: RL (released | freigegeben | valide) printed: 20.11.2019

