

По вопросам продаж и поддержки обращайтесь:

Архангельск (8182)63-90-72	Краснодар (861)203-40-90	Рязань (4912)46-61-64
Астана (7172)727-132	Красноярск (391)204-63-61	Самара (846)206-03-16
Белгород (4722)40-23-64	Курск (4712)77-13-04	Санкт-Петербург (812)309-46-40
Брянск (4832)59-03-52	Липецк (4742)52-20-81	Саратов (845)249-38-78
Владивосток (423)249-28-31	Магнитогорск (3519)55-03-13	Смоленск (4812)29-41-54
Волгоград (844)278-03-48	Москва (495)268-04-70	Сочи (862)225-72-31
Вологда (8172)26-41-59	Мурманск (8152)59-64-93	Ставрополь (8652)20-65-13
Воронеж (473)204-51-73	Набережные Челны (8552)20-53-41	Тверь (4822)63-31-35
Екатеринбург (343)384-55-89	Нижний Новгород (831)429-08-12	Томск (3822)98-41-53
Иваново (4932)77-34-06	Новокузнецк (3843)20-46-81	Тула (4872)74-02-29
Ижевск (3412)26-03-58	Новосибирск (383)227-86-73	Тюмень (3452)66-21-18
Казань (843)206-01-48	Орел (4862)44-53-42	Ульяновск (8422)24-23-59
Калининград (4012)72-03-81	Оренбург (3532)37-68-04	Уфа (347)229-48-12
Калуга (4842)92-23-67	Пенза (8412)22-31-16	Челябинск (351)202-03-61
Кемерово (3842)65-04-62	Пермь (342)205-81-47	Череповец (8202)49-02-64
Киров (8332)68-02-04	Ростов-на-Дону (863)308-18-15	Ярославль (4852)69-52-93

Единый адрес: btk@nt-rt.ru **Веб-сайт:** www.burkert.nt-rt.ru

Электромагнитные клапаны для нейтральных и слабоагрессивных сред Burkert

2/2-way fast switching solenoid valve with media separation

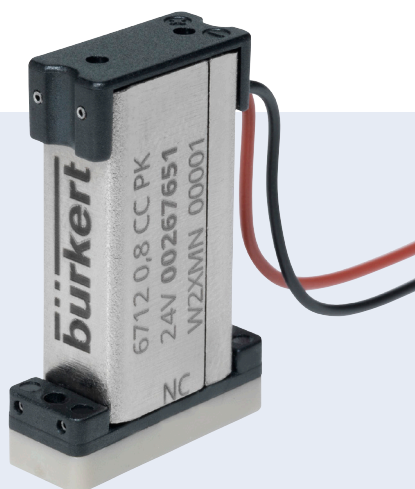

- Highest chemical resistance with minimal internal volume
- Compact design with 7 mm width
- Orifice size 0.8 mm (3 bar)
- Switching noise < 36 dB
- For dosing applications with excellent flush ability

Fluidical „point-of-care“ applications, as dialysis or artificial respiration, and applications at the „point-of-use“ for example at pipetting arms in biological analysis have special requirements. The new media separated solenoid valve type 6712 was particularly developed for these applications. Especially the reduced switching noise and the good flush ability set a new benchmark. But also in industrial applications like inkjet printers, the type 6712 is the first choice due to the high lifecycle and the excellent switching dynamic.

With the modular design and the available material variants this valve is applicable with virtually all liquids and gases in life science and industrial applications.

A valve that combines dosing accuracy and flush ability.

Circuit function A

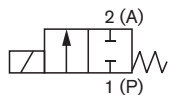

2/2-way valve, direct-acting, normally closed

Technical data	
Orifice sizes and pressure ranges	DN 0.8 mm with 0 to 3 bar ¹⁾ (DN 0.4 mm with 0 to 5 bar on request)
Tightness to outside	8 bar (rel.)
Body material	PEEK, PPS
Seal material	FFKM (EPDM and FKM on request)
Medium	Resistant to neutral and aggressive gases and liquids (acc. to Bürkert resistance chart)
Media temperature FFKM, FKM and EPDM	+15 to +55 °C
Ambient temperature FFKM, FKM and EPDM	+15 to +55 °C
Typical service life	30.000.000 (acc. to laboratory duration tests) ²⁾
Internal volume	< 5 µl
Viscosity	Max. 21 mm ² /s
Port connection	Bürkert flange (7 x 18.2 mm)
Electrical connection	Single flying leads, AWG26, 500 mm (Plug connector on request)
Power supply	24 V DC (12 V on request)
Voltage tolerance	±10 %
Power consumption	0.9 W ³⁾
Duty cycle	100 % continuous operation
Installation	As required, preferably with actuator upright
Protection class	IP40
Response times	Measurement at valve output with 1 bar and 20 °C acc. to DIN ISO 12238:2001 1 ms (pressure build-up 0-10 %) 5 ms (pressure build-up 100-90 %)
Switching frequency	50 Hz
Switching noise	< 36 dB ⁴⁾
Approvals and compliance (on request)	FDA KTW

¹⁾ Maximum tightened relative pressure at the seat. Max. pressure at the outlet: 1,5 bar (rel.).

²⁾ Service life depends on the type of medium, the temperature, the pressure, the seal material and the specific operational conditions.

³⁾ No further power reduction possible.

⁴⁾ Tested under Bürkert test conditions. The switching noise may vary with conditions.

Materials

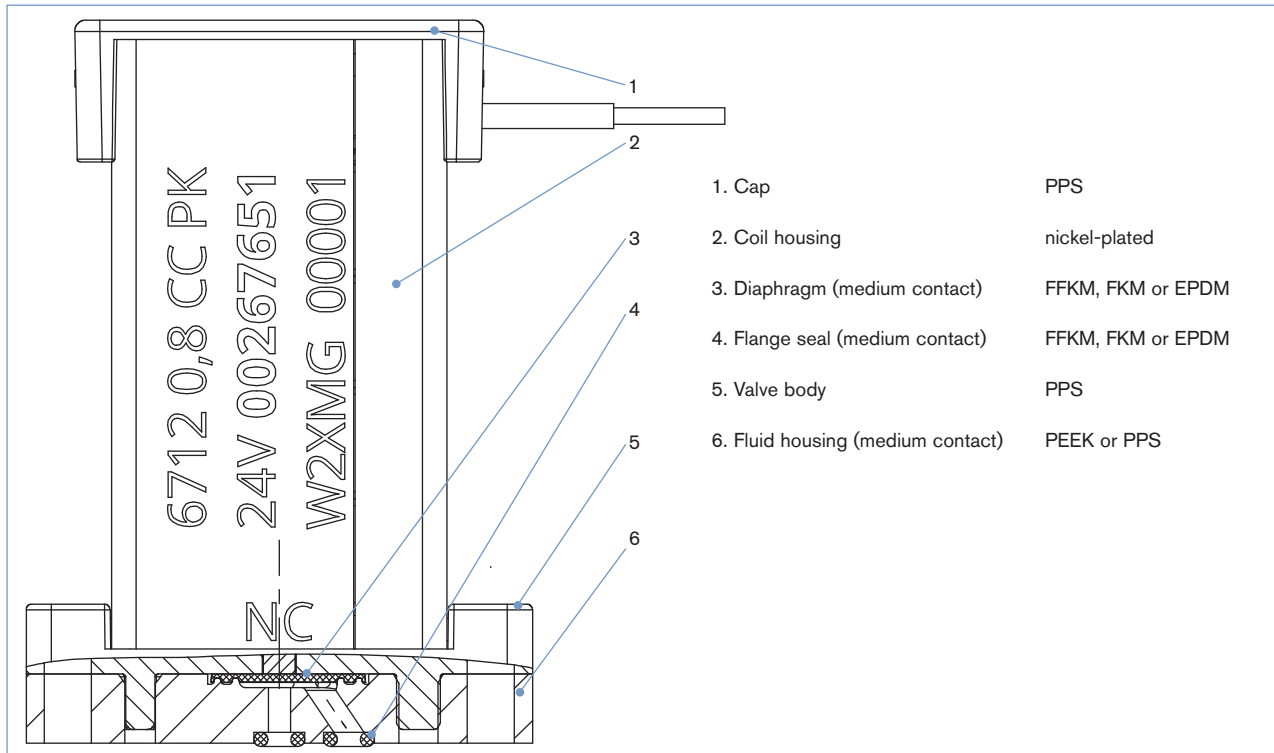

Dimensions [mm]

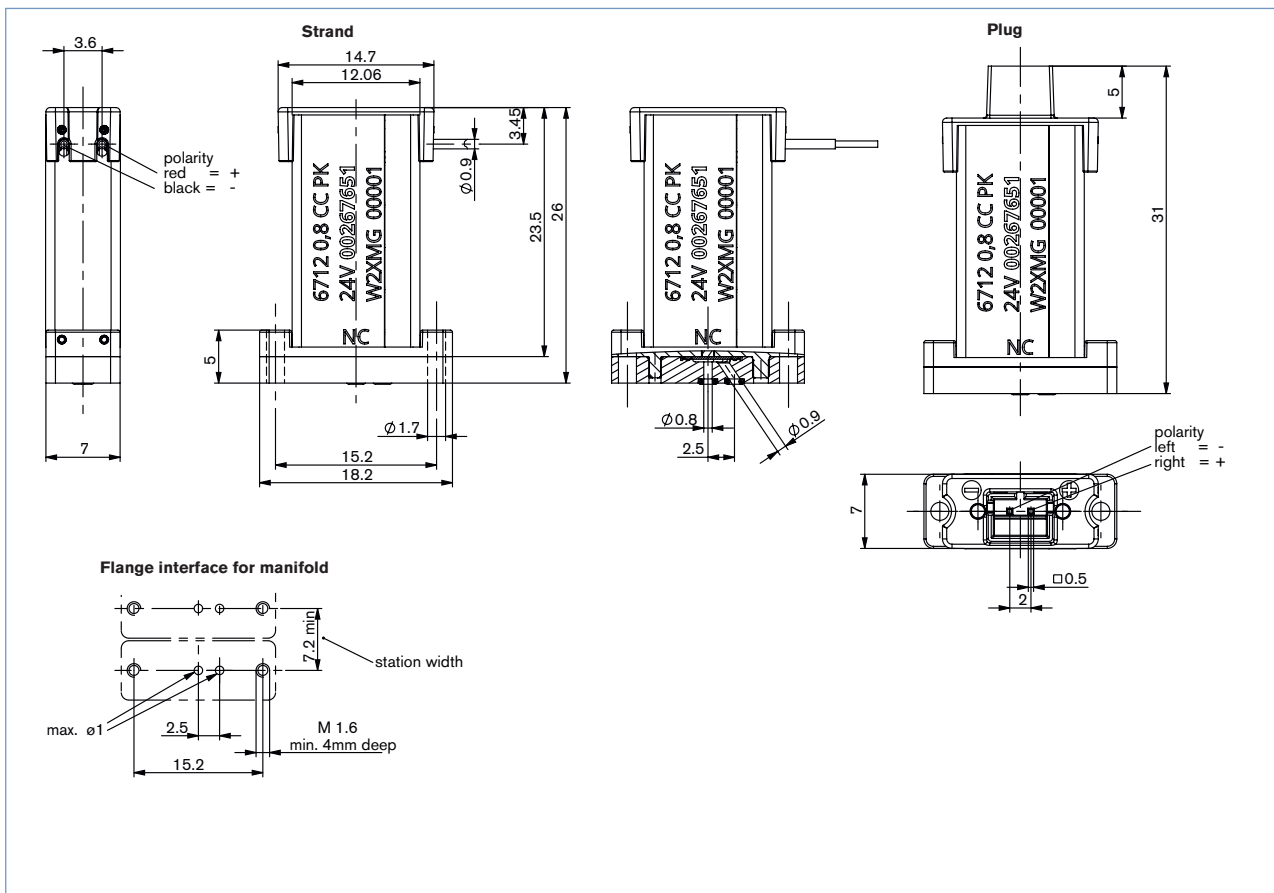

Ordering chart for valves

Circuit function	Orifice [mm]	Port connection	Kv value water [m ³ /h] ¹⁾	Cv value water [gpm]	QnN value air [l/min]	Pressure range [bar]	Max. pressure difference [bar]	Seal material	Body material	Electrical connection ²⁾	Voltage/frequency [V/Hz]	Item no.
A 2/2-way valve, direct acting, NC 	0.4	Bürkert flange	0.004	0.005	4.8	0-5	5	EPDM	PPS	Plug	12 V/DC	273 226 ³⁾
	0.8							FFKM	PEEK	Strand	24 V/DC	273 206 ³⁾
			EPDM	PPS	Plug	12 V/DC	273 232 ³⁾					
			FKM									
			FFKM	PEEK								
			EPDM	PPS	Strand		273 188 ³⁾					
			FKM									
			FFKM	PEEK	273 187 ³⁾							
			EPDM	PPS		Plug	24 V/DC	273 236 ³⁾				
			FKM									
			FFKM	PEEK	273 237 ³⁾							
	EPDM		PPS	Strand		273 190 ³⁾						
	FKM											
	FFKM		PEEK	267 651								

¹⁾ Kv value water [m³/h]: water flow rate measured at +20° C, 1 bar relative pressure. Kv value 0.013 m³/h only applies for p > 0.5 bar.
²⁾ Valves with plug connection are delivered without a mating plug. Suitable plug on request (compatibility to W+P, JST, Würth and Molex).
³⁾ On request.

i Further versions on request

Ordering chart for Manifold

Manifold with UNF connection; Delivery without valves; Material: PEEK

Manifold	Description	Item no.
1-fold	Manifold UNF 1/4"-28 PEEK	694 895

Other versions on request. UNF connectors and tubes are available as type TVU003.

To find your nearest Bürkert facility, click on the orange box →

