



## Guided microwave level measurement device

- Universal level measurement device for liquids
- Liquid interface measurement
- Insensitive to dust and steam
- 4... 20 mA/HART - 2 wires, ATEX/IECEx approvals 

Type 8188 can be combined with...



**Type 8619**  
multiCELL  
Transmitter/Controller



**Type 2035**  
Diaphragm valve



**Type 8802-GD**  
Continuous  
TopControl system

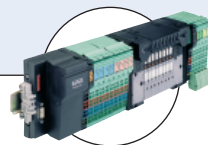

**Type 8644**  
Valve islands

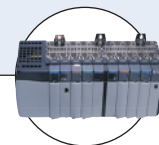

**PLC**

The Type 8188 is a level measurement device with cable, rod, both interchangeable probe or with coax probe, designed for continuous level measurement. The unit is suitable for liquids, for industrial use in all areas of process technology. With a measuring range up to 75 m, the 8188 is best suited for tall vessels. Even process conditions such as strong steam generation, density fluctuations or changes of the dielectric constant do not influence the accuracy of the measurement. Build-up or condensation on the probe or vessel wall do not influence the measuring result. A liquid interface measurement is also possible with the Type 8188, typically an oil/water interface.

### General data

#### Materials

Housing / Cover  
Seal ring / Ground terminal  
Wetted parts  
Process fitting  
Rod and cable

PBT, Stainless steel 316L (1.4404) / PC  
NBR / Stainless steel 316L

Coax- $\varnothing$  21.3 mm -  
Process seal  
Inner conductor  
(up to the separation cable/rod)  
Spacers  
Rod- $\varnothing$  8 mm  
Cable- $\varnothing$  4 mm with gravity weight  
Coax- $\varnothing$  21.3 mm (tube)

Stainless steel 316L\* and PPS for version up to 6 bar  
Stainless steel 316L\* and PEEK for version up to 40 bar  
Stainless steel 316L\* and PEEK  
FKM

Stainless steel 316L\*  
PFA (only for coax. probe version)  
Stainless steel 316L\*  
Stainless steel 316L\*  
Stainless steel 316L\*

#### Display

LCD in full dot matrix

#### Weight

Housing  
Rod- $\varnothing$  8 mm  
Cable- $\varnothing$  4 mm  
Coax- $\varnothing$  21.3 mm  
Gravity weight (only with cable version)

890 g  
approx. 400 g/m  
approx. 60 g/m  
approx. 1110 g/m  
approx. 200 g

#### Process fitting

Thread G or NPT - 3/4", 1"

#### Length

Rod- $\varnothing$  8 mm  
Cable- $\varnothing$  4 mm  
Coax- $\varnothing$  21.3 mm

0.3... 6 m - Lateral load: 10 Nm  
0.5... 75 m - Max. tensile load: 2.5 KN  
0.3... 6 m - Lateral load: 60 Nm

#### Electrical connections

Cable gland M20 x 1.5

#### Measurement type

Level of liquids

#### Min. dielectric figure

Rod and cable  
Coax- $\varnothing$  21.3 mm

$\epsilon_r > 1.6$   
 $\epsilon_r > 1.4$

\* (1.4404 or 1.4435)

General data (continued)	
<b>Dead band</b> in water Rod-ø 8 mm Cable-ø 4 mm Coax-ø 21.3 mm in oil Rod-ø 8 mm Cable-ø 4 mm Coax-ø 21.3 mm	From top of probe: 80 mm - from bottom of probe: 0 mm From top of probe: 80 mm - from bottom of probe: 0 mm From top of probe: 30 mm - from bottom of probe: 0 mm From top of probe: 150 mm - from bottom of probe: 50 mm From top of probe: 150 mm - from bottom of probe: 150 mm From top of probe: 100 mm - from bottom of probe: 50 mm
<b>Measurement range</b>	0.03... 6 m or 0.08... 75 m (see diagram on next pages)
<b>Process temperature</b>	-40 to 150°C (-40 to 302°F) (restricted up to 80°C (176°F) for rod and cable probe version up to 6 bar)
<b>Process pressure</b> (depends on the process fitting)	For process fitting in: stainless steel 316L*/PPS: -1 to 6 bar (-14.5 to 87 PSI) (-100... 600 kPa) stainless steel 316L*/PEEK: -1 to 40 bar (-14.5 to 580.1 PSI) (-100... 4000 kPa)
<b>Temperature drift</b>	0.03%/10K (Relating to the max. measurement range)
<b>Repeatability</b>	< ±1 mm
<b>Deviation</b>	±2 mm (see deviation diagram, on next pages)
Electrical data	
<b>Operating voltage (U<sub>n</sub>)</b>	9.6 - 35 V DC or 9.6 - 30 V DC (Ex ia instrument)
<b>Output signal</b>	4... 20 mA/HART [Range of the output signal 3.8... 20.5 mA/HART (default setting)]
<b>Resolution</b>	0.3 µA
<b>Fault signal</b> (adjustable)	Last valid measured value or ≥ 21 mA; ≤ 3.6 mA
<b>Current limitation</b>	21.5 mA (max. output current)
<b>Load</b>	(U <sub>n</sub> - U <sub>min.</sub> )/0.0215 A
<b>Integration time</b> (63% of the input variable)	0... 999 s, adjustable
Environment	
<b>Ambient temperature</b> with display, adjustment elements	-40 to +80°C (-4 to 176°F) (operation and storage)
<b>Relative humidity</b>	max. 75% (operation), max. 85% (storage); without condensation
Standards and approvals	
<b>Protection</b>	IP66/IP67 with M20 x 1.5 gland mounted and tightened
<b>Overvoltage category</b>	III (IEC 61010-1)
<b>Protection class</b>	III (IEC 61010-1)
<b>Standard</b>	
EMC	EN61326
Safety	EN61010-1
ATEX <sup>1)</sup>	EN60079-0; EN60079-11; EN60079-26
NAMUR	NE 21; NE 43
Specifications Ex	
<b>Ⓢ - Protection</b>	Categories 1 G, 1/2 G or 2 G
<b>Ⓢ - Certification</b>	Ex ia IIC T6
<b>Conformity specifications<sup>1)</sup></b>	
Operating voltage U <sub>i</sub>	30 V
Short circuit rating I <sub>i</sub>	131 mA
Power limitation P <sub>i</sub>	983 mW
Ambient temperature	-50 to +46°C (-40 to 105.8°F) (depend on categories)
Internal capacity C <sub>i</sub>	negligible
Internal inductivity L <sub>i</sub>	≤ 5 µH

<sup>1)</sup> homologation certificate IECEx TUR 14.0014 X / TÜV 14 ATEX 7490 X

### Measurement range diagram

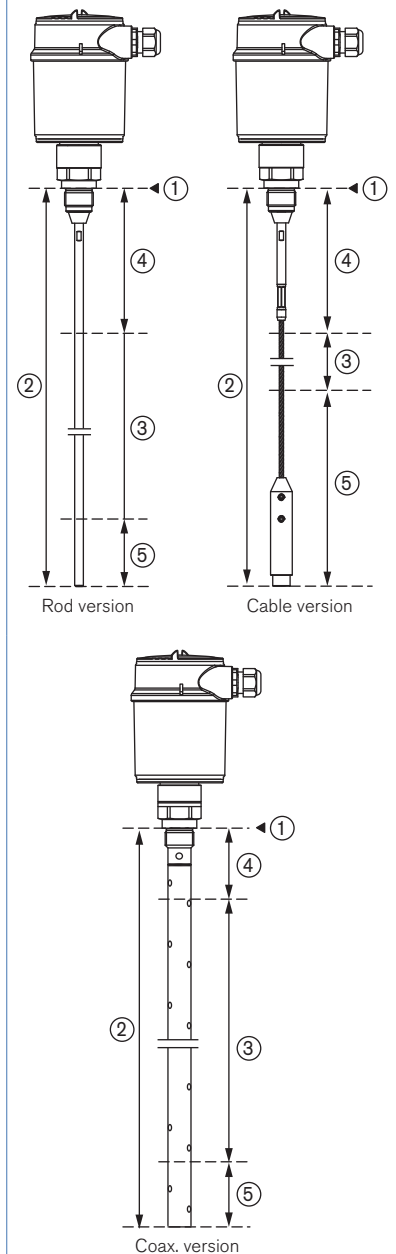

- 1 Reference plane
- 2 Probe length
- 3 Measurement range
- 4 Upper dead band
- 5 Lower dwead band

Deviation diagram

Rod probe version in water

- ① Dead band - no measurement possible in this area
- L Probe length

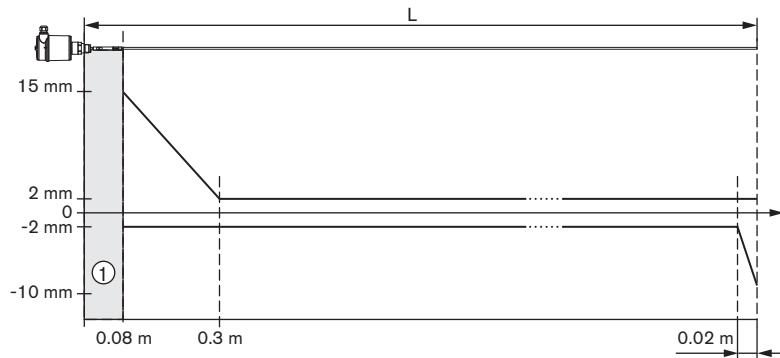

Rod probe version in oil

- ① Dead band - no measurement possible in this area
- L Probe length

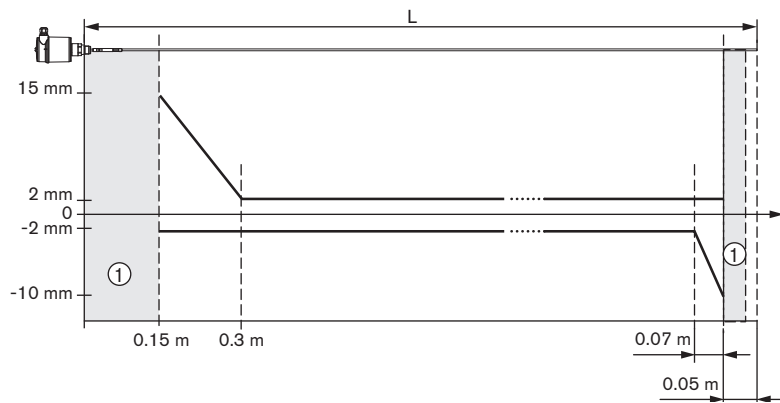

Cable probe version in water

- ① Dead band - no measurement possible in this area
- L Probe length

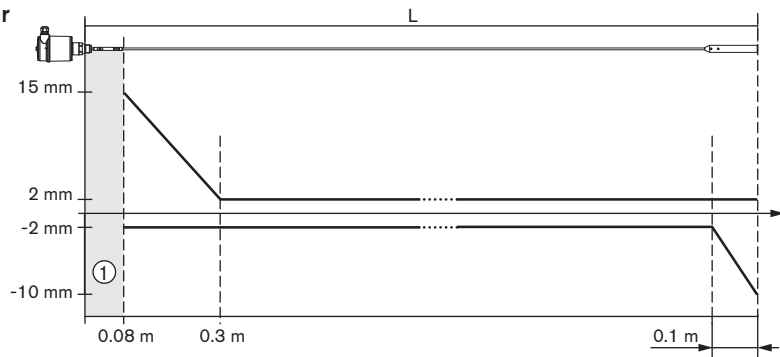

Cable probe version in oil

- ① Dead band - no measurement possible in this area
- L Probe length

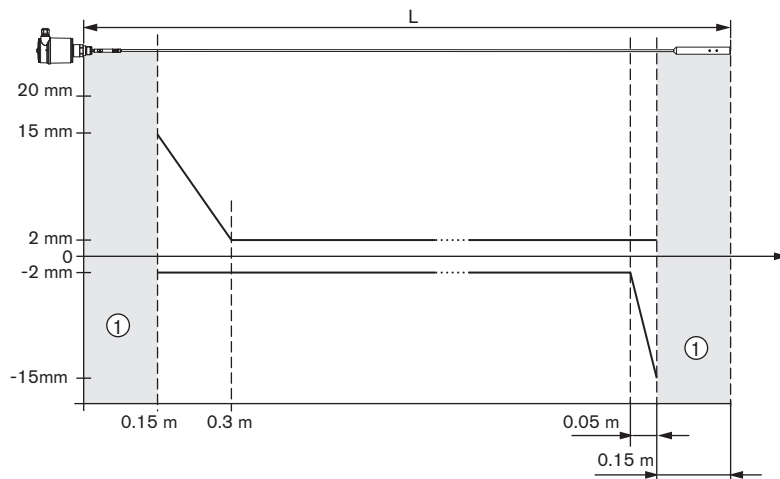

Deviation diagram (continued)

Rod probe version in water

- ① Dead band - no measurement possible in this area
- L Probe length

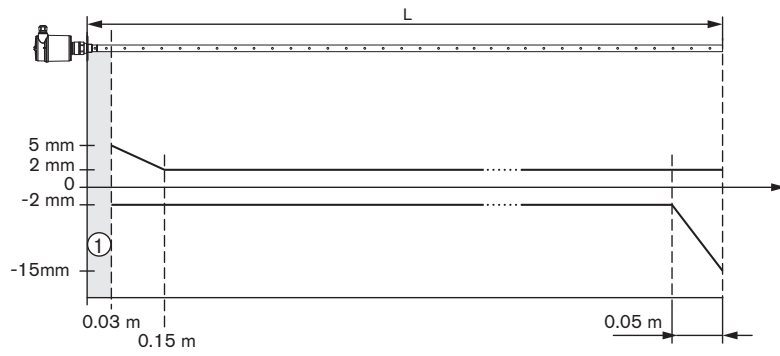

Rod probe version in oil

- ① Dead band - no measurement possible in this area
- L Probe length

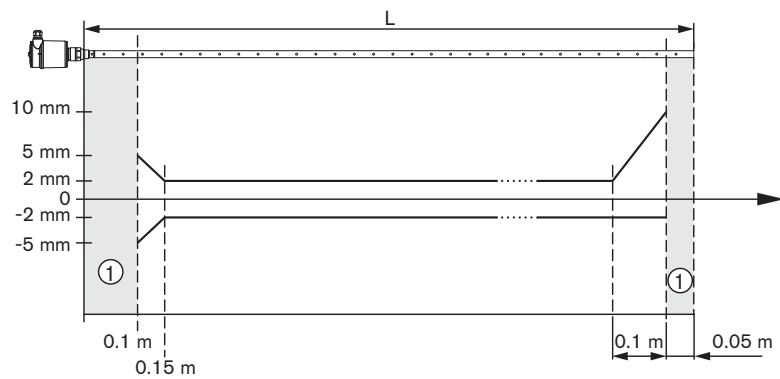

Load diagram

- 1 HART load
- 2 Voltage limit Ex ia instrument
- 3 Voltage limit non-Ex instrument
- 4 Supply voltage

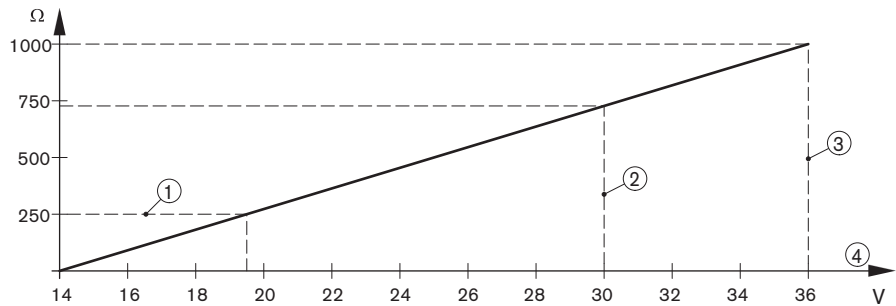

## Application examples with Type 8188

### Level measurement in

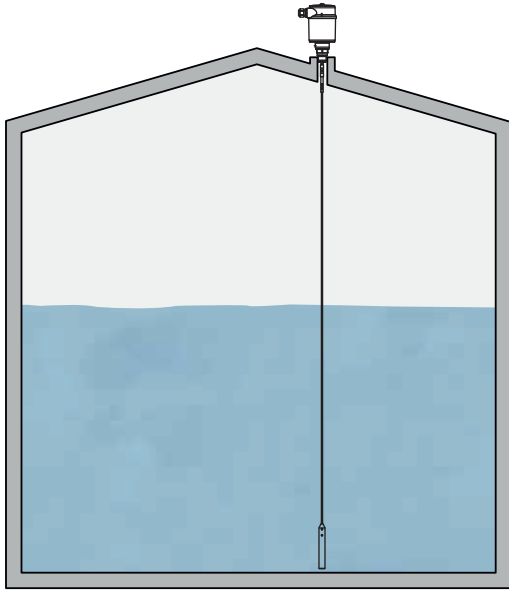

**bio-ethanol storage tanks**

After running through all process steps, the ethanol is ready for delivery to the consumer and is stored in a tank storage depot. Accurate measurement of the tank contents is a prerequisite for reliable logistics planning and ensures the supply to customers. Since the tanks often cannot be emptied after an initial filling, maintenance-free operation is an important criteria when selecting a suitable measurement technology

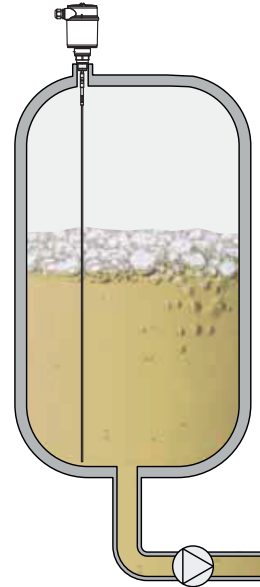

**volatile and low-viscosity solvents vessels**

The very low viscosity solvents diffuse through many plastics. This increases the demands placed on the measurement technology. To protect against overfilling, a separate level detection setup is also recommended. It increases system safety and guarantees protection of human health and the environment.

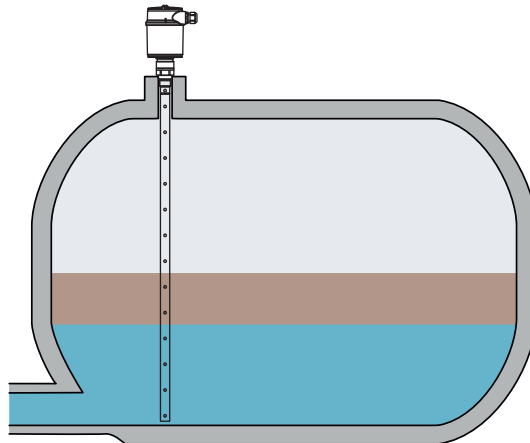

**separating tank,  
to determine the exact proportion of each substance**

Distillation products are often mixed with other substances of varying density and consistency. In the separating tank, for example, water is separated from the hydrocarbons and collected at the bottom of the tank. To determine the exact proportion of each substance, a so-called interface measurement is necessary

## Principle of operation

High frequency microwave pulses are guided along a steel cable, a rod or a coax. When they reach the product surface, the microwave pulses are reflected and received by the processing electronics. The running time is valuated by the instrument and outputted as distance.

Time consuming adjustment with medium is not necessary. The instruments are preset to the ordered probe length.

The shortenable cable, rod and coax. versions can be adapted individually to the local requirements.

The measuring device can be adjusted with:

- the display/configuration module
- the suitable Bürkert DTM in conjunction with adjustment software according to the FDT/DTM standard, e.g. PACTware™ and PC.
- a HART handheld

The entered parameters are generally saved in the measuring device Type 8188. Optionally, parameters may also be uploaded and downloaded with the display/configuration module or in PACTware™

### ▶ Set up with display/configuration module

The display/configuration module can be inserted into the measuring device and removed again at any time. It is not necessary to interrupt the power supply. The measuring device is adjusted via the four keys of the display/configuration module

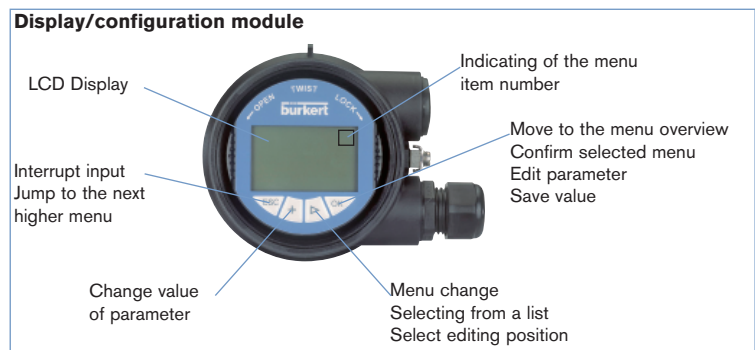

### Connecting the PC via HART

1. Measuring device 8188
2. HART-USB Modem
3. Resistance 250 Ohms

#### Necessary components:

- Measuring device 8188
- PC with PACTware™ and suitable Bürkert DTM
- HART-USB Modem
- Resistance approx. 250 Ohms
- Power supply unit

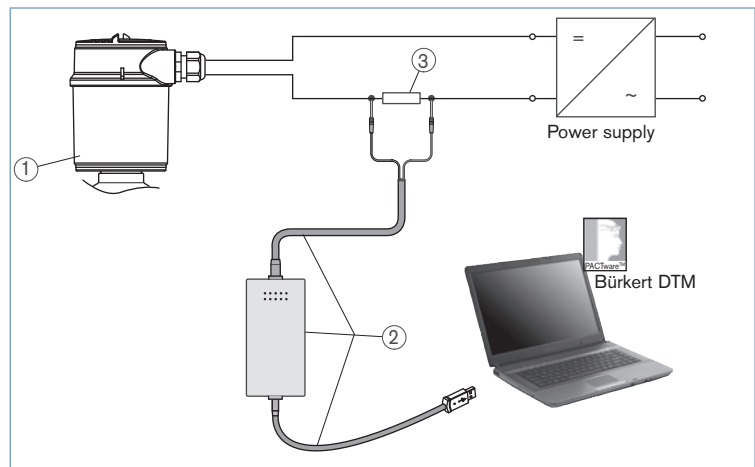

Dimensions [mm]

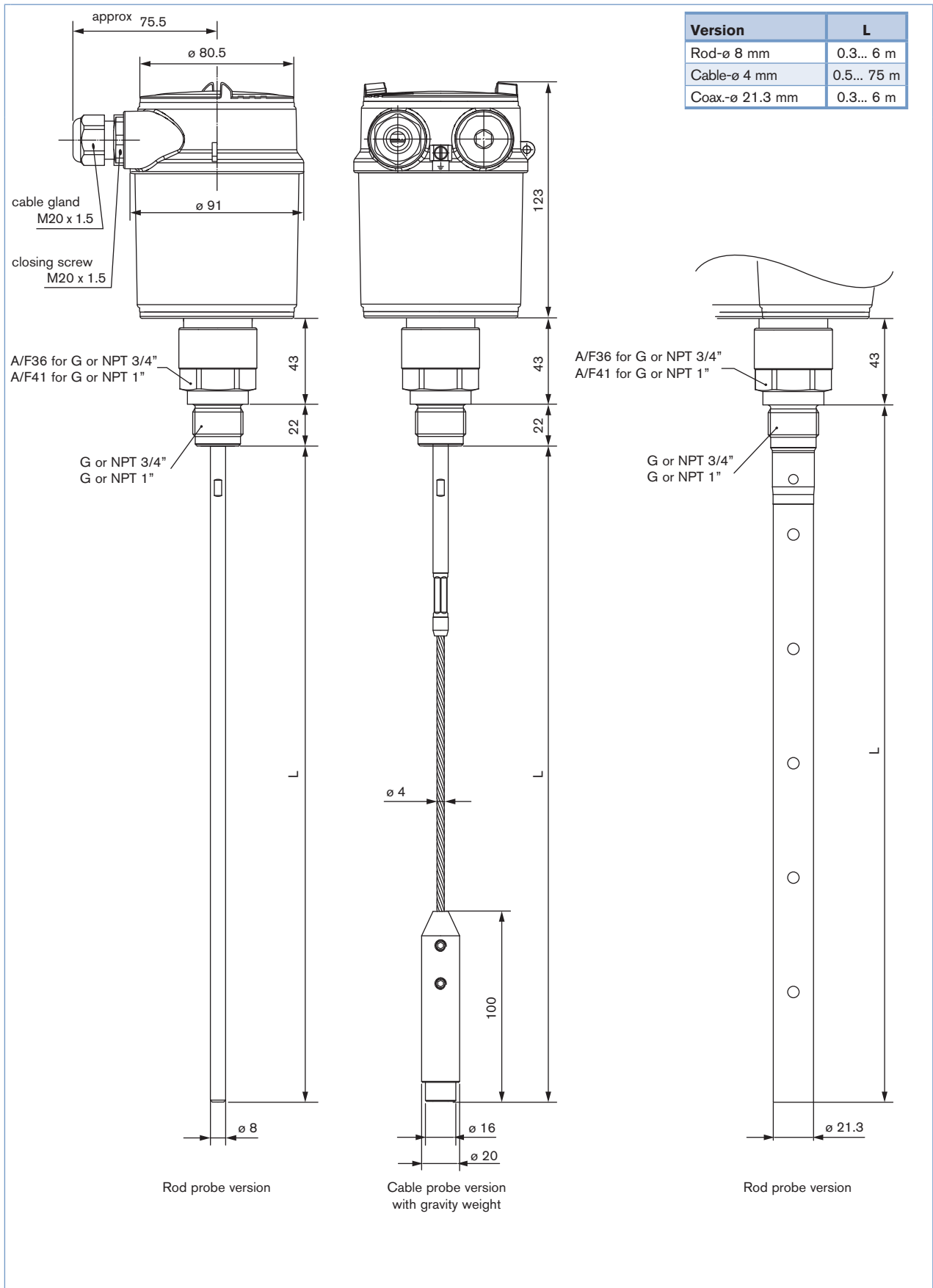



## Ordering chart for compact measurement device Type 8188

Specifications	Voltage supply	Output	Probe	Length	Electrical connection	Item no. with display/ configuration module
G 3/4" mounting thread, PN6, temp. max. 80°C	9.6 - 35 V DC	4 - 20 mA/HART (2 wires)	Rod	1 m	Cable gland M20 x 1.5	565 800
				2 m	Cable gland M20 x 1.5	565 804
			Cable	5 m	Cable gland M20 x 1.5	565 812
				10 m	Cable gland M20 x 1.5	565 816
			Coax.	1 m	Cable gland M20 x 1.5	565 823
				2 m	Cable gland M20 x 1.5	565 824
G 1" mounting thread, PN40, temp. max. 150°C	9.6 - 35 V DC	4 - 20 mA/HART (2 wires)	Rod	1 m	Cable gland M20 x 1.5	565 802
				2 m	Cable gland M20 x 1.5	565 806
			Cable	5 m	Cable gland M20 x 1.5	565 814
				10 m	Cable gland M20 x 1.5	565 818
			Coax.	1 m	Cable gland M20 x 1.5	565 825
				2 m	Cable gland M20 x 1.5	565 826
NPT 3/4" mounting thread, PN6, temp. max. 80°C	9.6 - 35 V DC	4 - 20 mA/HART (2 wires)	Rod	1 m	Cable gland M20 x 1.5	565 801
				2 m	Cable gland M20 x 1.5	565 805
			Cable	5 m	Cable gland M20 x 1.5	565 813
				10 m	Cable gland M20 x 1.5	565 817
			Coax.	1 m	Cable gland M20 x 1.5	565 827
				2 m	Cable gland M20 x 1.5	565 828
NPT 1" mounting thread, PN40, temp. max. 150°C	9.6 - 35 V DC	4 - 20 mA/HART (2 wires)	Rod	1 m	Cable gland M20 x 1.5	865 803
				2 m	Cable gland M20 x 1.5	565 807
			Cable	5 m	Cable gland M20 x 1.5	565 815
				10 m	Cable gland M20 x 1.5	565 819
			Coax.	1 m	Cable gland M20 x 1.5	565 829
				2 m	Cable gland M20 x 1.5	565 830

## Ordering chart for compact measurement device Type 8188 (continued)

Specifications	Voltage supply	Output	Probe	Length	Electrical connection	Item no. with display/ configuration module	
Ex version - ATEX approval - G 3/4" mounting thread, PN6, temp. max. 80°C	9.6 - 30 V DC	4 - 20 mA/HART (2 wires)	Rod	1 m	Cable gland M20 x 1.5	565 808	
				2 m	Cable gland M20 x 1.5	565 810	
			Cable	5 m	Cable gland M20 x 1.5	565 820	
				Coax.	1 m	Cable gland M20 x 1.5	565 831
					2 m	Cable gland M20 x 1.5	565 832
				Ex version - ATEX approval - G 1" mounting thread, PN40, temp. max. 150°C	9.6 - 30 V DC	4 - 20 mA/HART (2 wires)	Rod
2 m	Cable gland M20 x 1.5	565 811					
Cable	5 m	Cable gland M20 x 1.5	565 821				
	Coax.	1 m	Cable gland M20 x 1.5				565 833
		2 m	Cable gland M20 x 1.5				565 834
	Ex version - IECEx approval - NPT 3/4" mounting thread, PN6, temp. max. 80°C	9.6 - 30 V DC	4 - 20 mA/HART (2 wires)				Rod
2 m				Cable gland M20 x 1.5	565 840		
Cable				5 m	Cable gland M20 x 1.5	565 841	
				Coax.	1 m	Cable gland M20 x 1.5	565 835
					2 m	Cable gland M20 x 1.5	565 836
				Ex version - IECEx approval - NPT 1" mounting thread, PN40, temp. max. 150°C	9.6 - 30 V DC	4 - 20 mA/HART (2 wires)	Rod
2 m	Cable gland M20 x 1.5	565 843					
Cable	5 m	Cable gland M20 x 1.5	565 844				
	Coax.	1 m	Cable gland M20 x 1.5				565 837
		2 m	Cable gland M20 x 1.5				565 838

 Further versions on request

## Port connection

Thread G or NPT 1/2" (PN40, 150°C), 1"1/2  
 Flange DN25, DN40, DN50, DN80, DN100, DN150  
 Flange 1", 1"1/2, 2", 3", 4", 6"



## Additional

Without display

## Ordering chart - accessories for measurement device Type 8188 (has to be ordered separately)

Specifications	Item no.
Set with 2 reductions M20 x 1.5/NPT1/2" + 2 neoprene flat seals for cable gland + 2 screw-plugs M20 x 1.5	551 782
Hart-USB Modem	560 177
Set with a display/configuration module, a transparent cover and a seal ring	559 279
Set with a transparent cover and a seal ring	561 006

**Guided microwave level measurement device Type 8188 - request for quotation**

**Note**  
You can fill out the fields directly in the PDF file before printing out the form.

Please fill in and send to your local Bürkert Sales Centre\* with your inquiry or order.

Company:	Contact person:
Customer No.:	Department:
Address:	Tel. / Fax.:
Postcode / Town:	E-mail:

**Guided microwave level measuring device 8188**

Quantity:       Desired delivery date:

■ **Process connection:**

**External thread**     G 3/4", PN6, 80°C     G 1"     G 1 1/2"     G 3/4", PN40, 150°C  
 NPT 3/4", PN6, 80°C     NPT 1"     NPT 1 1/2"     NPT 3/4", PN40, 150°C

**Flange**     DN25     DN40     DN50  
 DN80     DN100     DN150  
 ANSI 1"     ANSI 1 1/2"     ANSI 2"  
 ANSI 3"     ANSI 4"     ANSI 6"

■ **Sensor version:**

**Probe**     Rod     Cable     Coax.  
**Length**     1 m     2 m     5 m     10 m  
 Spec. length  mm (multiple of 100 mm between 300 and 6000 mm for Rod version or coax version - multiple of 100 mm between 500 and 75000 mm for cable version)

■ **Display/configuration module**     Yes     No

■ **ATEX approval**     Yes     No

■ **IECEX approval**     Yes     No

**Interconnection possibilities with other Bürkert devices**

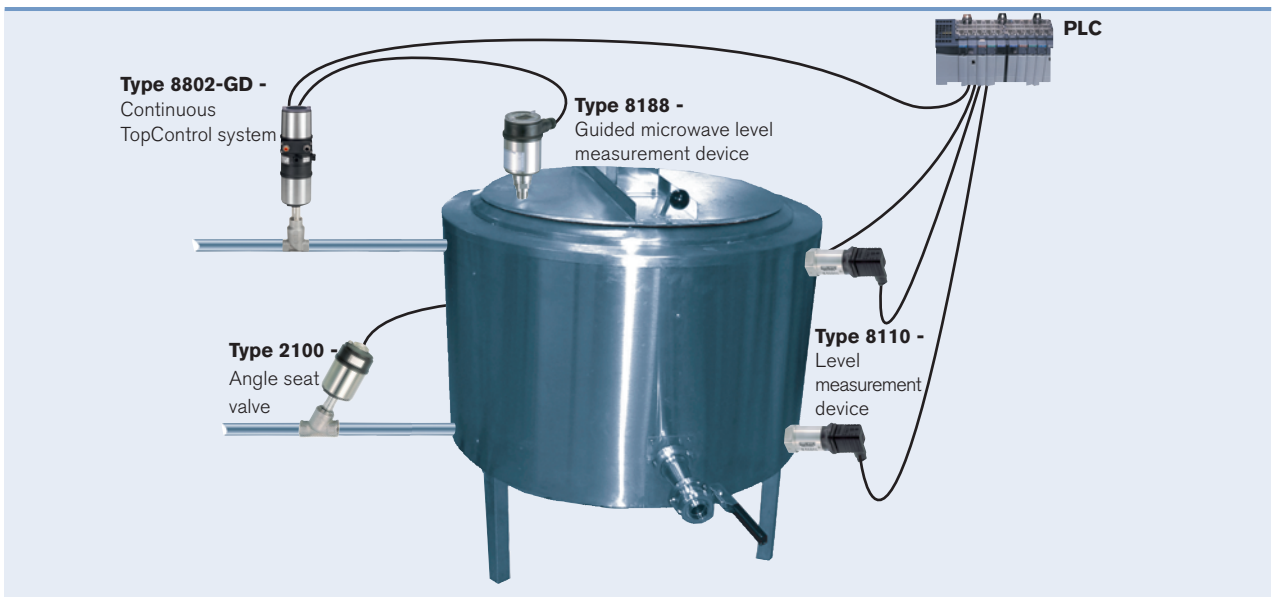

\*To find your nearest Bürkert facility, click on the orange box →

## Guided microwave level measurement device - sanitary version

- Universal level measurement device for liquids
- Liquid interface measurement
- Insensitive to dust and steam

- 4... 20 mA/Hart - 2 wires, ATEX/IECEx approvals 

Type 8189 can be combined with...

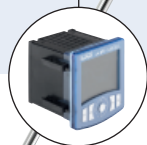

**Type 8619**  
multiCELL  
Transmitter/Controller



**Type 2035**  
Diaphragm valve



**Type 8802-GD**  
Continuous  
TopControl system

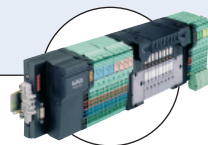

**Type 8644**  
Valve islands

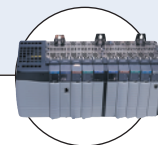

**PLC**

The Type 8189 is a level measurement device with interchangeable rod probe, designed for continuous level measurement. The unit is suitable for liquids, for industrial use in all areas of process technology. But the main application targets are in Food and Beverage (F&B) and pharmaceutical tanks to the new rod in stainless steel 1.4435 with  $R_a < 0.76 \mu\text{m}$ . For applications with corrosive liquids a PFA coated version is available.

Even process conditions such as strong steam generation, density fluctuations or changes of the dielectric constant do not influence the accuracy of the measurement.

Build-up or condensation on the probe or vessel wall do not influence the measurement result.

### General data

<b>Materials</b>	
Housing / Cover	PBT, Stainless steel 316L (1.4404) / PC
Seal ring / Ground terminal	NBR / Stainless steel 316L
Wetted parts	
Process fitting / process seal	Stainless steel 316L (1.4404 or 1.4435) and PEEK / EPDM
Rod- $\varnothing$ 8 mm - polished	Stainless steel 316L (1.4435)
<b>Rod surface finish</b>	$R_a < 0.76 \mu\text{m}$ (BN2)
<b>Display</b>	LCD in full dot matrix
<b>Weight</b>	
Housing	890 g
Rod- $\varnothing$ 8 mm	approx. 400 g/m
<b>Process fitting</b>	Clamp 2" or DIN11851 DN50
<b>Length</b>	0.3... 4 m - Lateral load: 10 Nm
<b>Electrical connections</b>	Cable gland M20 x 1.5
<b>Measurement type</b>	Level of liquids
<b>Min. dielectric figure</b>	$\epsilon_r > 1.6$
<b>Dead band</b>	
in water	From top of probe: 80 mm - from bottom of probe: 0 mm
in oil	From top of probe: 150 mm - from bottom of probe: 100 mm
<b>Measurement range</b>	0.08... 4 m (see diagram on next page)
<b>Process temperature</b>	-20 to 150°C (-4 to 302°F)
<b>Process pressure</b>	-1 to 16 bar (-14.51 to 232.16 PSI) (-100... 1600 kPa) (depends on the process fitting)
<b>Temperature drift</b>	0.03%/10K (Relating to the max. measurement range)
<b>Repeatability</b>	$< \pm 1 \text{ mm}$
<b>Deviation</b>	$\pm 2 \text{ mm}$ (see deviation diagram, on next page)

Electrical data	
<b>Operating voltage (U<sub>n</sub>)</b>	9.6 - 35 V DC or 9.6 - 30 V DC (Ex ia instrument)
<b>Output signal</b>	4... 20 mA/HART [Range of the output signal 3.8... 20.5 mA/HART (default setting)]
<b>Resolution</b>	0.3 $\mu$ A
<b>Fault signal</b> (adjustable)	Last valid measured value or $\geq 21$ mA or $\leq 3.6$ mA
<b>Current limitation</b>	21.5 mA (max. output current)
<b>Load</b>	(U <sub>n</sub> - U <sub>min.</sub> )/0.0215 A
<b>Integration time</b> (63% of the input variable)	0... 999 s, adjustable
Environment	
<b>Ambient temperature</b> with display, adjustment elements	-40 to +80°C (-4 to 176°F) (operation and storage)
<b>Relative humidity</b>	max. 75% (operation), max. 85% (storage); without condensation
Standards and approvals	
<b>Protection</b>	IP66/IP67 with M20 x 1.5 gland mounted and tightened
<b>Overvoltage category</b>	III (IEC 61010-1)
<b>Protection class</b>	III (IEC 61010-1)
<b>Standard</b>	EN61326 / EN61010-1
EMC / Safety	EN60079-0; EN60079-11; EN60079-26
ATEX <sup>1)</sup>	NE 21; NE 43
NAMUR	
<b>Approvals</b>	FDA
Specifications Ex	
<b>⊕ - Protection</b>	Categories 1 G, 1/2 G or 2 G
<b>⊕ - Certification</b>	Ex ia IIC T6
<b>Conformity specifications<sup>1)</sup></b>	
Operating voltage U <sub>i</sub>	30 V
Short circuit rating I <sub>i</sub>	131 mA
Power limitation P <sub>i</sub>	983 mW
Ambient temperature	-50 to +46°C (-40 to 105.8°F) (depend on categories)
Internal capacity C <sub>i</sub>	negligible
Internal inductivity L <sub>i</sub>	$\leq 5$ $\mu$ H

1) homologation certificate IECEx TUR 14.0014 X / TÜV 14 ATEX 7490 X

### Measurement range diagram

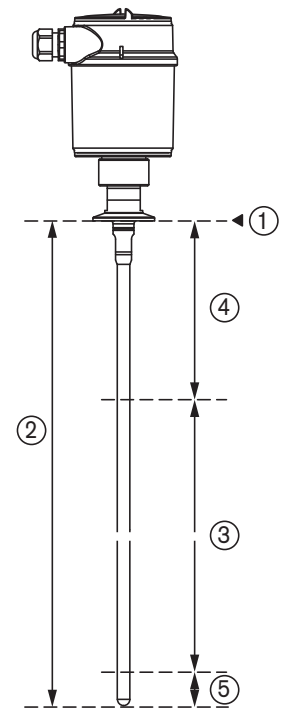

- 1 Reference plane
- 2 Probe length
- 3 Measurement range
- 4 Upper dead band
- 5 Lower dead band

### Deviation diagram

#### Rod probe version in water

- ① Dead band - no measurement possible in this area  
L Probe length

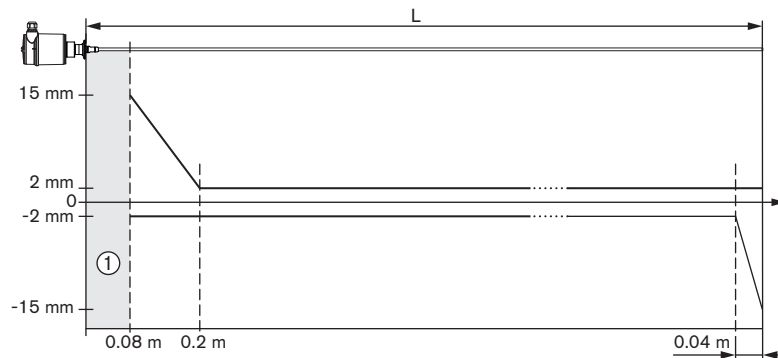

#### Rod probe version in oil

- ① Dead band - no measurement possible in this area  
L Probe length

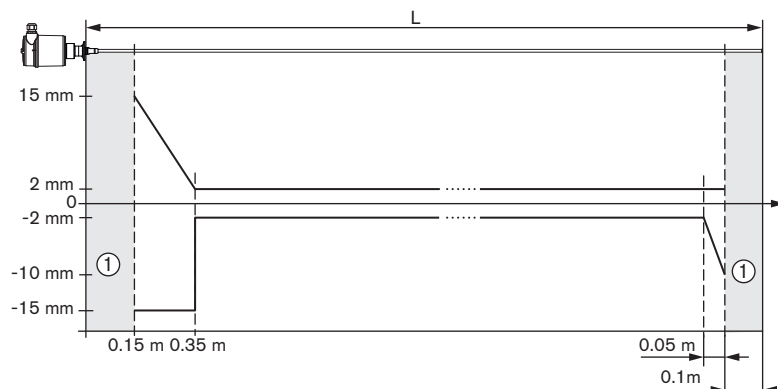

**Load diagram**

- 1 HART load
- 2 Voltage limit Ex ia instrument
- 3 Voltage limit non-Ex instrument
- 4 Supply voltage

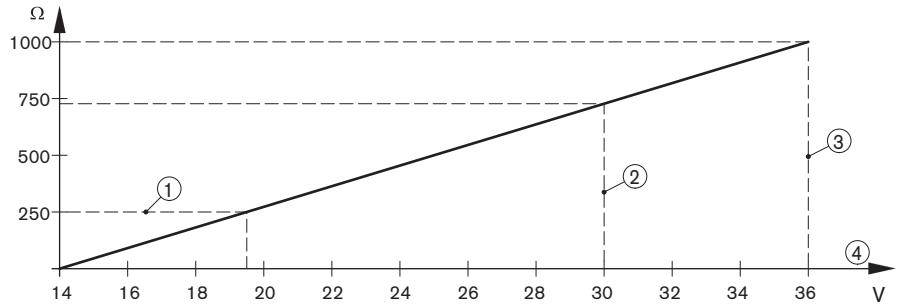
**Target applications with Type 8189****Foodstuffs and animal feed**

Products such as beer, milk, wine, cereals, sugar, flour, coffee, cornflakes, cacao, instant powder, animal feed - liquids or bulk solids levels must be measured everywhere in the food industry.

The microwave principle works independent of products characteristics such as moisture, intense dust or noise generation, density, temperature, over-pressure, foam dielectric value and the shape of the material cone.

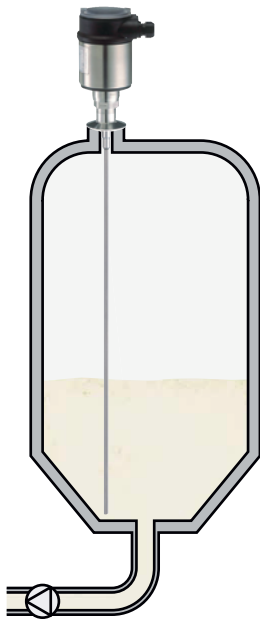
**Application examples**

Level measurement in a milk vessel

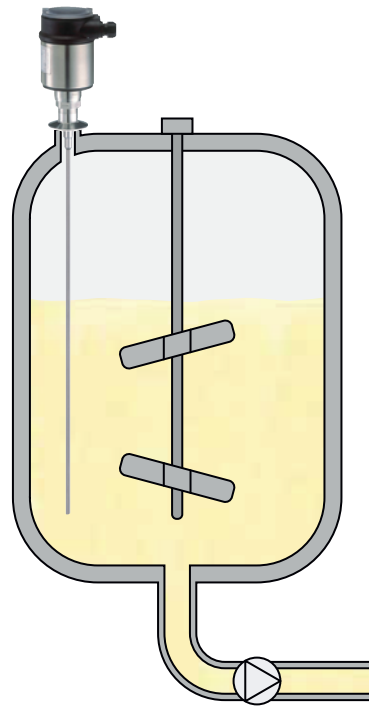

Level measurement in an ice cream vessel

## Principle of operation

High frequency microwave pulses are guided along a rod. When they reach the product surface, the microwave pulses are reflected and received by the processing electronics. The running time is valuated by the instrument and outputted as distance.

Time consuming adjustment with medium is not necessary. The instruments are preset to the ordered probe length.

The shortenable rod versions can be adapted individually to the local requirements.

The measuring device can be adjusted with:

- the display/configuration module
- the suitable Bürkert DTM in conjunction with adjustment software according to the FDT/DTM standard, e.g. PACTware™ and PC.
- a HART handheld

The entered parameters are generally saved in the measuring device Type 8189. Optionally, parameters may also be uploaded and downloaded with the display/configuration module or in PACTware™

### ▶ Set up with display/configuration module

The display/configuration module can be inserted into the measuring device and removed again at any time. It is not necessary to interrupt the power supply. The measuring device is adjusted via the four keys of the display/configuration module

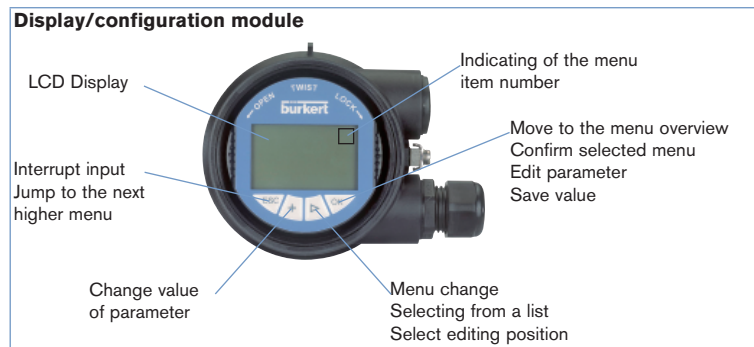

### Connecting the PC via HART

1. Measuring device 8189
2. HART-USB Modem
3. Resistance 250 Ohms

#### Necessary components:

- Measuring device 8189
- PC with PACTware™ and suitable Bürkert DTM
- HART-USB Modem
- Resistance approx. 250 Ohms
- Power supply unit

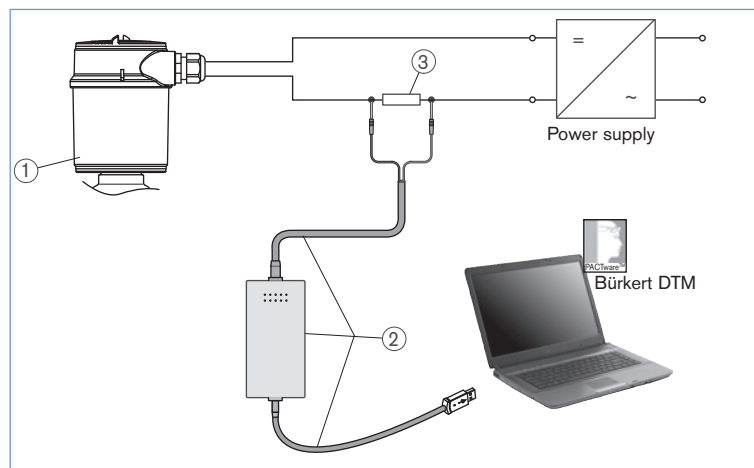

Dimensions [mm]

with Clamp connection

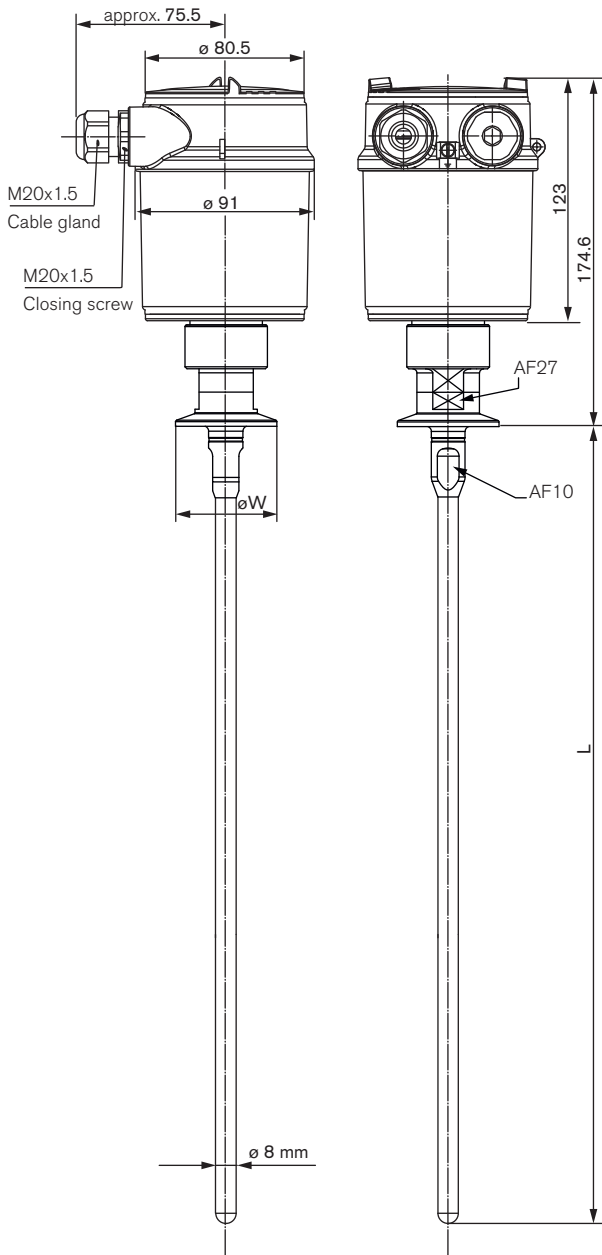

Clamp connection	ø W	L
1", 1 1/2"	50.5	0.3... 4 m
2"	64.0	
2 1/2"	77.5	
3"	91.0	

with DIN 11851 connection

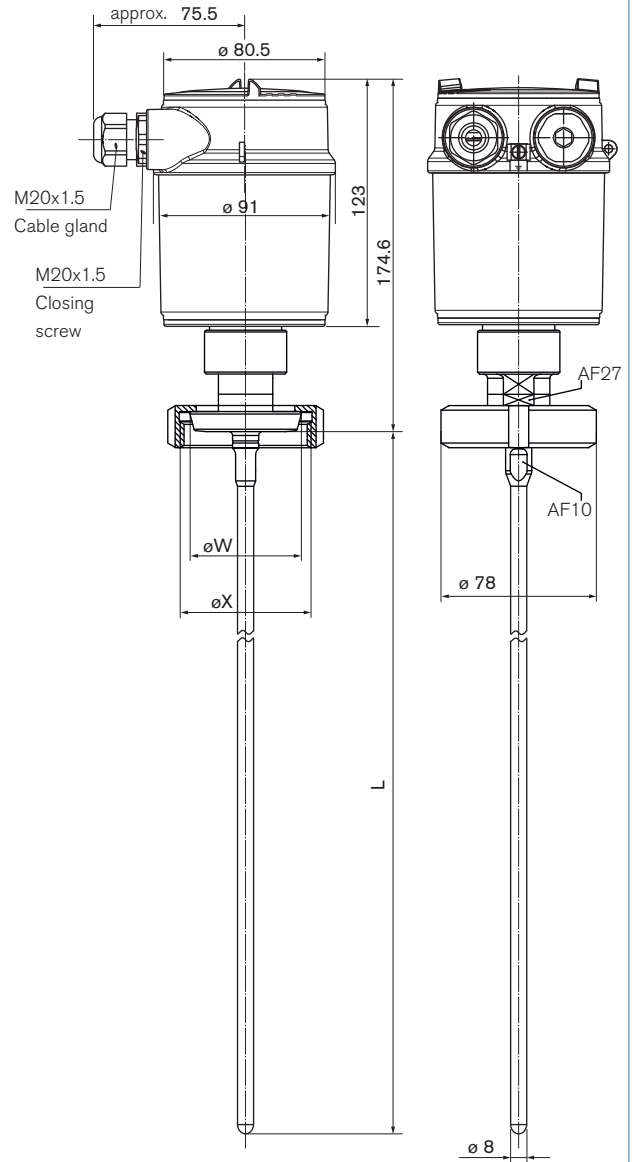

DIN 11851 connection	ø W	ø X	L
DN32	50.0	Rd 58x1/6	0.3... 4 m
DN40	56.0	Rd 65x1/6	
DN50	68.5	Rd 78x1/6	
DN65	86.0	Rd 95x1/6	



## Ordering chart for compact measurement device Type 8189

Specifications	Voltage supply	Output	Probe	Length	Electrical connection	Item no. with display/ configuration module
Clamp 2"	9.6 - 35 V DC	4 - 20 mA/HART (2 wires)	Rod	1 m	Cable gland M20 x 1.5	565 850
				2 m	Cable gland M20 x 1.5	565 852
DIN11851 - DN50	9.6 - 35 V DC	4 - 20 mA/HART (2 wires)	Rod	1 m	Cable gland M20 x 1.5	565 851
				2 m	Cable gland M20 x 1.5	565 853
Ex version - ATEX approval - Clamp 2"	9.6 - 30 V DC	4 - 20 mA/HART (2 wires)	Rod	1 m	Cable gland M20 x 1.5	565 854
				2 m	Cable gland M20 x 1.5	565 856
Ex version - ATEX approval - DIN11851 DN50	9.6 - 30 V DC	4 - 20 mA/HART (2 wires)	Rod	1 m	Cable gland M20 x 1.5	565 855
				2 m	Cable gland M20 x 1.5	565 857
Ex version - IECEx approval - Clamp 2"	9.6 - 30 V DC	4 - 20 mA/HART (2 wires)	Rod	1 m	Cable gland M20 x 1.5	565 858
				2 m	Cable gland M20 x 1.5	565 860
Ex version - IECEx approval - DIN11851 DN50	9.6 - 30 V DC	4 - 20 mA/HART (2 wires)	Rod	1 m	Cable gland M20 x 1.5	565 859
				2 m	Cable gland M20 x 1.5	565 861

 Further versions on request

## Port connection

Clamp 1"1/2, 2"1/2, 3"  
DIN 11851 DN32, DN40, DN65



## Additional

Without display/configuration module

## Ordering chart - accessories for measurement device Type 8189 (has to be ordered separately)

Specifications	Item no.
Set with 2 reductions M20 x 1.5/NPT1/2" + 2 neoprene flat seals for cable gland + 2 screw-plugs M20 x 1.5	551 782
Hart-USB Modem	560 177
Set with a display/configuration module, a transparent cover and a seal ring	559 279
Set with a transparent cover and a seal ring	561 006

**Guided microwave level measurement device Type 8189 - request for quotation**

**Note**  
You can fill out the fields directly in the PDF file before printing out the form.

Please fill in and send to your local Bürkert Sales Centre\* with your inquiry or order.

Company:	Contact person:
Customer No.:	Department:
Address:	Tel. / Fax.:
Postcode / Town:	E-mail:

**Guided microwave level measurement device 8189**

Quantity:       Desired delivery date:

■ **Process connection:**

**Clamp**       1"1/2       2"       2"1/2       3"

**DIN 11851**       DN32       DN40       DN50       DN65

■ **Sensor version:**

**Length**       1 m       2 m  
 Spec. length  mm (multiple of 100 mm between 300 and 4000 mm for Rod version)

■ **Display/configuration module**       Yes       No

■ **ATEX approval**       Yes       No

■ **IECEX approval**       Yes       No

■ **FDA approval**       Yes       No

**Interconnection possibilities with other Bürkert devices**

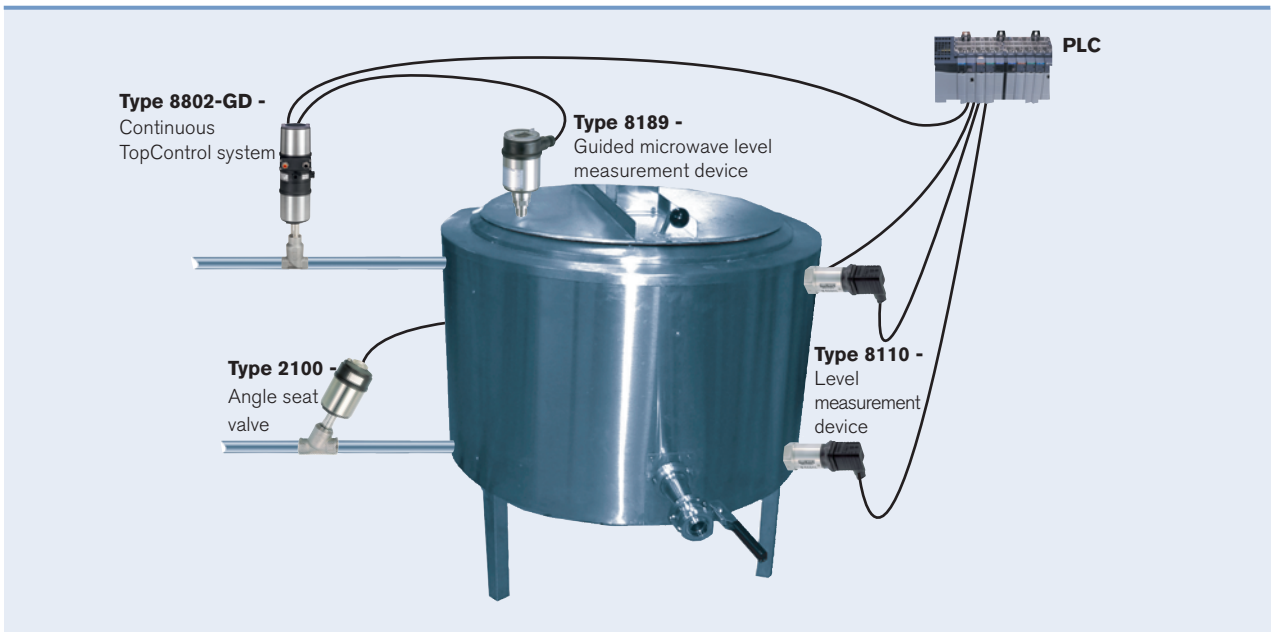

\*To find your nearest Bürkert facility, click on the orange box →

