

По вопросам продаж и поддержки обращайтесь:

Архангельск (8182)63-90-72	Краснодар (861)203-40-90	Рязань (4912)46-61-64
Астана (7172)727-132	Красноярск (391)204-63-61	Самара (846)206-03-16
Белгород (4722)40-23-64	Курск (4712)77-13-04	Санкт-Петербург (812)309-46-40
Брянск (4832)59-03-52	Липецк (4742)52-20-81	Саратов (845)249-38-78
Владивосток (423)249-28-31	Магнитогорск (3519)55-03-13	Смоленск (4812)29-41-54
Волгоград (844)278-03-48	Москва (495)268-04-70	Сочи (862)225-72-31
Вологда (8172)26-41-59	Мурманск (8152)59-64-93	Ставрополь (8652)20-65-13
Воронеж (473)204-51-73	Набережные Челны (8552)20-53-41	Тверь (4822)63-31-35
Екатеринбург (343)384-55-89	Нижний Новгород (831)429-08-12	Томск (3822)98-41-53
Иваново (4932)77-34-06	Новокузнецк (3843)20-46-81	Тула (4872)74-02-29
Ижевск (3412)26-03-58	Новосибирск (383)227-86-73	Тюмень (3452)66-21-18
Казань (843)206-01-48	Орел (4862)44-53-42	Ульяновск (8422)24-23-59
Калининград (4012)72-03-81	Оренбург (3532)37-68-04	Уфа (347)229-48-12
Калуга (4842)92-23-67	Пенза (8412)22-31-16	Челябинск (351)202-03-61
Кемерово (3842)65-04-62	Пермь (342)205-81-47	Череповец (8202)49-02-64
Киров (8332)68-02-04	Ростов-на-Дону (863)308-18-15	Ярославль (4852)69-52-93

Единый адрес: btk@nt-rt.ru **Веб-сайт:** www.burkert.nt-rt.ru

**ШАРОВЫЕ КРАНЫ,
ЗАТВОРЫ ДИСКОВЫЕ**

2671
double eccentric

Butterfly Valve, high performance



- Pressure rating: 285 psig-based on service temperature
- ISO 5211 direct actuator mount
- Range of body, disc, stem, and seat options
- Wafer and Lug Style, PTFE/Metal Seated

Type 2671 can be combined with...



Type 6519 NAMUR
Pilot valve, direct mount to actuator



Type 2051
Pneumatic rotary actuator



Type 3003
Electric rotary actuator



Type 3004
Electric explosion proof actuator



Type 3005
Electric rotary actuator



Type 8792
Positioner

The Burkert Double Eccentric High Performance Butterfly Valve has many configurations available to meet a wide range of demanding applications. The 2671 Double Eccentric is automation ready with an ISO 5211 mounting flange for direct coupling of the actuator. A full range of actuators, pilot valves, digital positioners, feedback switches and bus network options are available for integration in plant process control systems.

Technical data

Valve size	2"-24" wafer and lug style
Body materials	Carbon Steel, 304 and 316 stainless steel
Disc material	Carbon Steel, 304 and 316 stainless steel
Seat material	PTFE, PTFE+15% Glass, PTFE+15% Graphite
Stem material	Stainless Steel
Media temperature	-20 °F to 410 °F based on valve seat limit
Connections	Wafer and Lug
Installation	As required
Pressure rating	285 psig based on the seat material temperature rating

Specifications

Scope:

The specification covers the design and testing of high performance double eccentric design butterfly valves.

Applicable standards:

The following standards shall apply

ANSI B16.5:	Pipe Flanges and Flanged Fittings (24" size and smaller)
ANSI B16.34:	Valves-Flanged and Butt welding End.
ANSI/FCI 70-2:	Control Valve Seat leakage.
MSS SP-25:	Standard Marking System for Valves, Fittings, Flanges and Unions
MSS SP-61:	Pressure Testing of Steel Valves
MSS SP-68:	High Pressure-Offset Seat Butterfly Valves
API 598:	Valve Inspection and Testing
API 609:	Butterfly Valves, Lug-Type and Wafer-Type
API 607:	Fire Test for Soft-seated Quarter-turn Valves
PED:	Pressure Equipment Directive Module H
ISO 5208:	Inspection regulation of valve
ISO 5211:	Part-turn actuator attachment
ISO 5752:	Face-to-Face and center-to-face dimensions
ISO 9001:	Quality assurance system

Design features:

1. Valves are high performance with offset seat and double eccentric disc design.
2. Valve seats are designed for full pressure, bidirectional sealing.
3. Valve is equipped with upper and lower low friction bearings.
4. One-Piece shaft design equipped with Blow-Out Proof and Anti-Static devices.
5. Patented Seat Retainer Ring fixed without bolts and offering complete uninterrupted seal face.
6. Valve has integral body stop to prevent over travel

Inspection and test:

1. Valves shall be hydrostatically shell tested as per ANSI B16.34, MSS SP-61 , API 598 , and ISO 5208
2. Valves shall be seat tested per MSS SP-61 or ISO 5208 No leakage is permitted for resilient seated valves.
And allowable leakage of metal seated valves are as per ANSI/FCI 70-2.
3. API 598 testing available upon request.

Materials:

1. Stainless steel valves shall be constructed from materials below:
 - Body-ASTM A351 CF8 or CF8M
 - Disc-ASTM A351 CF8 or CF8M
2. Carbon steel valves shall be constructed form materials below:
 - Body-ASTM A105 or A216 WCB
 - Disc-ASTM A351 CF8 or CF8M
3. Stem material shall be one of the following ASTM A564 Type 630 (17-4PH)
A182 F304 or F316

Construction details

Stem (10) - One-Piece design with ISO 5211 square drive. **Packing (7)** - Multiply Rows of Teflon Chevron. **Retainer (4)** - Patented design of square thread, ensures an uninterrupted sealing face. Flange face equipped with 125 - 200AARH finish and is compatible with both flat and spiral wound gaskets. **Integral Disc stop (10)** - To prevent disc from over travel. **Teflon Seat (3)** - Pressure assisted to give Bidirectional bubble tight shut off at all pressures. (Valve must be installed with retaining ring upstream for dead end service.) **Thrust Ring (11)** - Anti blowout shaft and Anti static design. **Bearings (5&6)** - Upper and Lower bearings are constructed of PTFE impregnated 316 SS. **Yoke (15)** - Investment Cast, per ISO 5211. **Fugitive Emissions Packing System** is available on customer required.

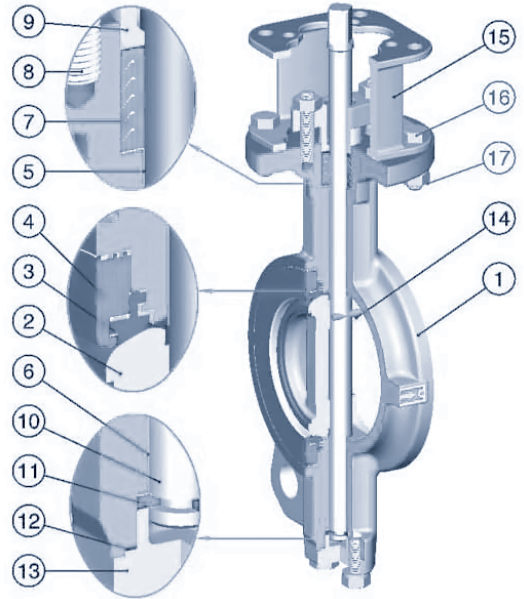

Item	Part name	Materials	Specifications		Comments
			JIS	ASTM	
1	Body	Carbon Steel	SC480	A216 Gr. WCB	
		Stainless steel	SCS 13A	A351 Gr. CF8	
			SCS 14A	A351 Gr. CF8M	
			SCS 16A	A351 Gr. CF3M	
2	Disc	Stainless Steel	SCS 13A	A351 Gr. CF8	Disc edge has to be hard chrome plated when equipped RTFE seat
			SCS 14A	A351 Gr. CF8M	
			SCS 16A	A351 Gr. CF3M	
3	Seat	PTFE			-20.2 °F to 320 °F (-29 °C to 160 °C)
		PTFE+15%Glass	RPTFE		-20.2 °F to 356 °F (-29 °C to 180 °C)
		PTFE+15%Graphite	RPTFE		-20.2 °F to 410 °F (-29 °C to 210 °C)
4	Retainer	Stainless steel	SCS 13A	A351 Gr. CF8	
			SCS 14A	A351 Gr. CF8M	
			SCS 16A	A351 Gr. CF3M	
5	Bushing	PTFE+316SS			
6	Bushing	PTFE+316SS			
7	Gland Packing	PTFE			-20.2 °F to 320 °F (-29 °C to 160 °C)
		PTFE+15%Graphite	RPTFE		-20.2 °F to 410 °F (-29 °C to 210 °C)
8	Stud	Steel	SUS 304	A193 Gr. B8	
9	Gland	Stainless Steel	SCS 13A	A351 Gr. CF8	
			SCS 14A	A351 Gr. CF8M	
10	Stem	Stainless Steel	SUS 410	A182 Gr. F6a	Stem has to be hard chrome plated when equipped with PTFE + Graphite gland packing
			SUS 304	A182 Gr. F304	
			SUS 316	A182 Gr. F316	
			SUS 630	A564 Gr. 630	
			XM-19	A479 Gr. XM-19	
11	Thrust Ring	Stainless Steel	SUS 316	A240 Gr. 316	
12	Seal	PTFE			
13	Bottom Cover	Stainless Steel	SCS 13A	A351 Gr. CF8	
			SCS 14A	A351 Gr. CF8M	
			SCS 16A	A351 Gr. CF3M	
		Carbon Steel	SC480	A216 Gr. WCB	
14	Pin	Stainless Steel	SUS 316	A182 Gr. F316	
15	Yoke	Ductile Iron	FCD 450	A536 Gr. 65-45-12	For 24" valve only
		Carbon Steel	SC480	A216 Gr. WCB	Regular
		Stainless Steel	SCS 13A	A351 Gr. CF8	Option
16	Bolt	Stainless Steel	SUS 304	A193 Gr. B8	
17	Nut	Stainless Steel	SUS 304	A194 Gr. 8	

Construction details

Stem (10) - One-Piece design with ISO 5211 square drive. **Packing (7)** - Graphite packing ensures no leakage during fire. **Retainer (4)** - Patented design of square thread, ensures an uninterrupted sealing face. Flange face equipped with 125 - 200 AARH finish and is compatible with both flat and spiral wound gaskets. **Integral Disc stop (1)** - To prevent disc from over travel. **Fire-safe Seat (3&19)** - Bidirectional soft seat(3) design for zero leakage in normal operation and a metal-to-metal seal(19) after fire, meets "Fire-safe" requirement. (Valve must be installed with retaining ring upstream for dead end service.) **Thrust Ring (11)** - Anti blowout shaft and Anti static design. **Bearings (5&6)** - Upper and Lower bearings are constructed of PTFE impregnated 316 SS. **Yoke (15)** - Investment Cast, per ISO 5211 . **Fugitive Emissions Packing System** is available on customer required.

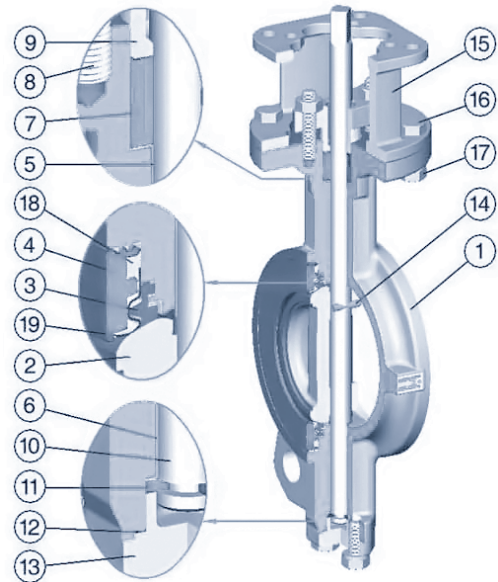

Item	Part name	Materials	Specifications		Comments
			JIS	ASTM	
1	Body	Carbon Steel	SC480	A216 Gr. WCB	
		Stainless steel	SCS 13A	A351 Gr. CF8	
			SCS 14A	A351 Gr. CF8M	
			SCS 16A	A351 Gr. CF3M	
2	Disc	Stainless Steel	SCS 13A	A351 Gr. CF8	Disc edge has to be hard chrome plated
			SCS 14A	A351 Gr. CF8M	
			SCS 16A	A351 Gr. CF3M	
3	Seat	PTFE			-20.2 °F to 320 °F (-29 °C to 160 °C)
		PTFE+15%Glass			-20.2 °F to 356 °F (-29 °C to 180 °C)
		PTFE+15%Graphite			-20.2 °F to 410 °F (-29 °C to 210 °C)
4	Retainer	Stainless steel	SCS 13A	A351 Gr. CF8	
			SCS 14A	A351 Gr. CF8M	
			SCS 16A	A351 Gr. CF3M	
5	Bushing	PTFE+316SS			
6	Bushing	PTFE+316SS			
7	Gland Packing	Graphite			
8	Stud	Stainless Steel	SUS 304	A193 Gr. B8	
9	Gland	Stainless Steel	SCS 14A	A351 Gr. CF8	
			SCS 16A	A351 Gr. CF8M	
10	Stem	Stainless Steel	SUS 410	A182 Gr. F6a	Stem equipped with hard chrome plated
			SUS 304	A182 Gr. F304	
			SUS 316	A182 Gr. F316	
			SUS 630	A564 Gr. 630	
			XM-19	A479 Gr. XM-19	
11	Thrust Ring	Stainless Steel	SUS 316	A240 Gr. 316	
12	Seal	Graphite			
13	Bottom Cover	Stainless Steel	SCS 13A	A351 Gr. CF8	
			SCS 14A	A351 Gr. CF8M	
			SCS 16A	A351 Gr. CF3M	
		Carbon Steel	SC480	A216 Gr. WCB	
14	Pin	Stainless Steel	SUS 316	A182 Gr. F316	
15	Yoke	Ductile Iron	FCD 450	A536 Gr. 65-45-12	For 24" valve only
		Carbon Steel	SC480	A216 Gr. WCB	Regular
		Stainless Steel	SCS 13A	A351 Gr. CF8	Option
16	Bolt	Stainless Steel	SUS 304	A193 Gr. B8	
17	Nut	Stainless Steel	SUS 304	A194 Gr. 8	
18	Gasket	Graphite			
19	Metal Seat	Stainless Steel	SUS 316	A240 Gr. 316	Nitrided

Construction details

Stem (10) - One-Piece design with ISO 5211 square drive. **Packing (7)** - Graphite packing ensures no leakage during fire. **Retainer (4)** - Patented design of square thread, ensures an uninterrupted sealing face. Flange face equipped with 125 - 200 AARH finish and is compatible with both flat and spiral wound gaskets. **Integral Disc stop (1)** - To prevent disc from over travel. **Metal Seat (3)** - Bidirectional self sealing metal seat design for leakage rated at Class IV per ANSI FCI 70-2 or better. (Retaining ring fixed at upstream when dead end service.) **Thrust Ring (11)** - Anti blow out shaft and Anti static design. **Bearings (5&6)** - Upper and Lower bearings are constructed of 316 SS Nitrided. **Yoke (15)** - Investment Cast, per ISO 5211. **Fugitive Emissions Packing System** is available on customer required.

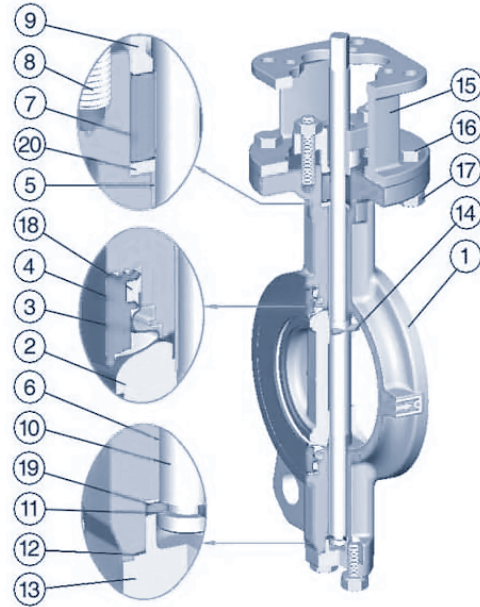

Item	Part name	Materials	Specifications		Comments
			JIS	ASTM	
1	Body	Carbon Steel	SC480	A216 Gr. WCB	
		Stainless steel	SCS 13A	A351 Gr. CF8	
2	Disc	Stainless Steel	SCS 14A	A351 Gr. CF8M	
			SCS 16A	A351 Gr. CF3M	
			SCS 13A	A351 Gr. CF8	Disc edge has to be hard chrome plated
3	Metal Seat	Stainless Steel	SUS 316	A240 Gr. 316	Nitrided
4	Retainer	Stainless steel	SCS 13A	A351 Gr. CF8	
			SCS 14A	A351 Gr. CF8M	
			SCS 16A	A351 Gr. CF3M	
5	Bushing	Stainless Steel	SUS 316	A182 Gr. F316	Nitrided
6	Bushing	Stainless Steel	SUS 316	A182 Gr. F316	Nitrided
7	Gland Packing	Graphite			
8	Stud	Stainless Steel	SUS 304	A193 Gr. B8	
9	Gland	Stainless Steel	SCS 13A	A351 Gr. CF8	
			SCS 14A	A351 Gr. CF8M	
10	Stem	Stainless Steel	SUS 410	A182 Gr. F6a	Stem equipped with hard chrome plated
			SUS 304	A182 Gr. F304	
			SUS 316	A182 Gr. F316	
			SUS 630	A564 Gr. 630	
			XM-19	A479 Gr. XM-19	
11	Thrust Ring	Stainless Steel	SUS 316	A240 Gr. 316	
12	Seal	Graphite			
13	Bottom Cover	Stainless Steel	SCS 13A	A351 Gr. CF8	
			SCS 14A	A351 Gr. CF8M	
			SCS 16A	A351 Gr. CF3M	
14	Pin	Carbon Steel	SC480	A216 Gr. WCB	
		Stainless Steel	SUS 316	A182 Gr. F316	
15	Yoke	Ductile Iron	FCD 450	A536 Gr. 65-45-12	For 24" valve only
		Carbon Steel	SC480	A216 Gr. WCB	Regular
		Stainless Steel	SCS 13A	A351 Gr. CF8	Option
16	Bolt	Stainless Steel	SUS 304	A193 Gr. B8	
17	Nut	Stainless Steel	SUS 304	A194 Gr. 8	
18	Gasket	Graphite			
19	Washer	Stainless Steel	SUS 316	A240 Gr. 316	
20	Washer	Stainless Steel	SUS 316	A240 Gr. 316	

Specifications

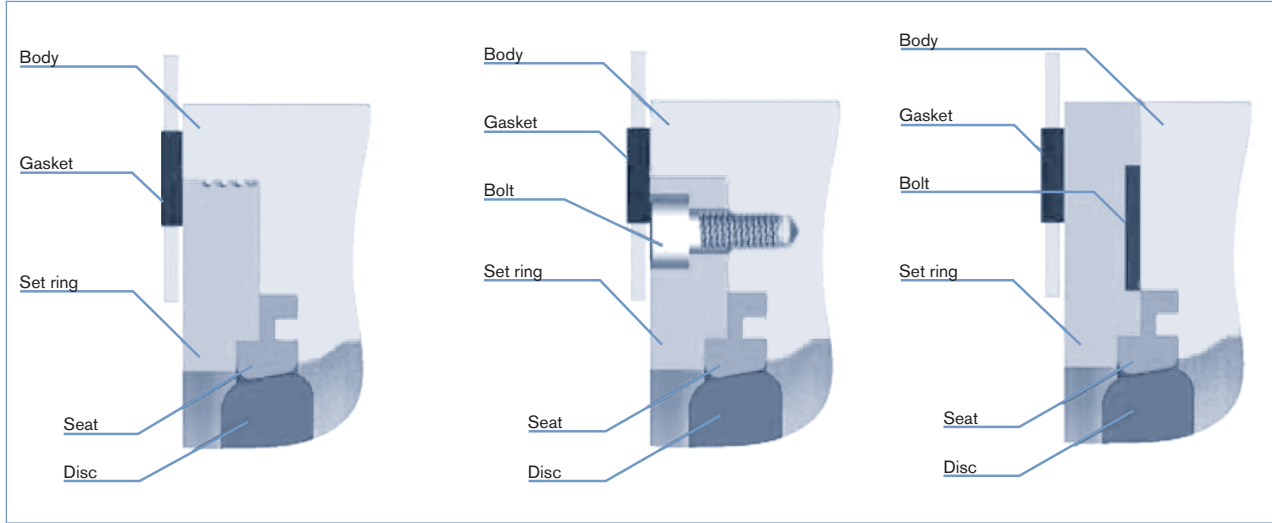

CV-values

Size		Valve open degree								
inch	mm	10°	20°	30°	40°	50°	60°	70°	80°	90°
2"	50	0.3	2	6	12	20	32	50	62	66
2½"	65	1	11	27	40	60	83	106	133	140
3"	80	2	20	50	73	110	154	200	250	260
4"	100	4	32	80	120	180	250	320	400	420
5"	125	7	55	140	200	300	430	550	680	720
6"	150	11	90	230	340	510	710	910	1140	1200
8"	200	20	150	390	560	850	1190	1520	1900	2000
10"	250	30	240	600	870	1310	1840	2360	2940	3100
12"	300	40	360	920	1330	2000	2800	3600	4500	4750
14"	350	55	450	1130	1640	2500	3500	4500	5500	5850
16"	400	75	650	1600	2300	3500	4900	6300	7850	8300
18"	450	95	800	2000	2900	4400	6100	7900	9900	10400
20"	500	125	1000	2700	3900	5900	8200	10500	13000	13800
24"	600	200	1700	4400	6300	9500	13300	17000	21300	22500

NOTE: Retaining ring must be upstream for dead end service.

Seat Rating (psig)

Temperature		Class 150	
°F	°C	PTFE	RPTFE
-20 °F to 100 °F	-29 °C to 38 °C	285	285
150 °F	66 °C	273	273
200 °F	93 °C	260	260
250 °F	121 °C	245	245
300 °F	149 °C	230	230
350 °F	177 °C	140	215
400 °F	204 °C	50	100
410 °F	210 °C	39	78

Wafer type dimension [mm]

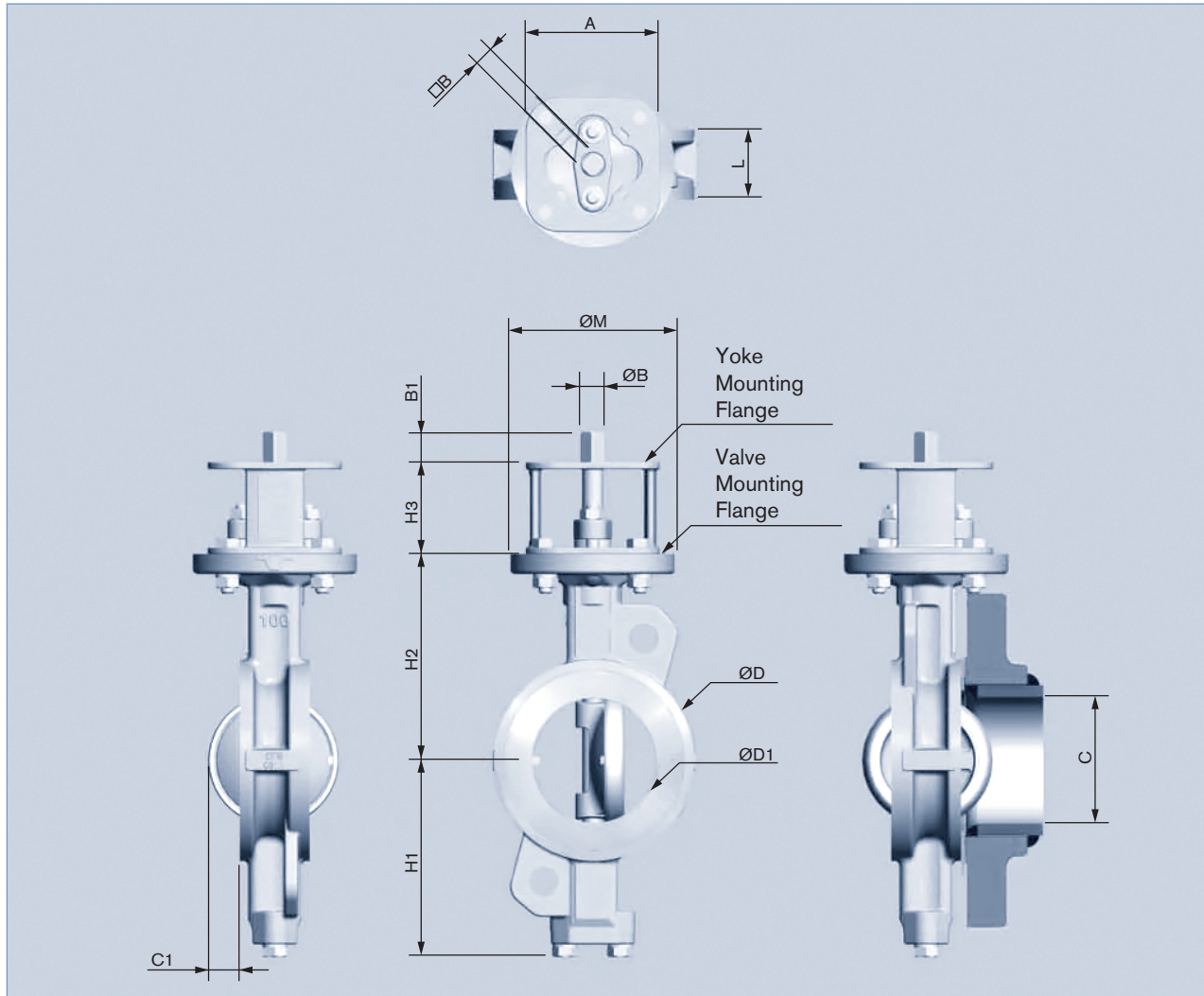

Size	Face to face	Dimensions							Mounting flange (ISO 5211)				Shaft end			Suitable pipe flange	Weight
		L	H1	H2	H3	ØD	ØD1	C	C1	Valve Type	ØM	Yoke Type	M1	ØB	□B		
50	43	99	118	60	92	37	49.5	2	F07	90	F05	70	14	11	18	ACDEFKMN	8.59
65	46	110	125	60	108	63	62.3	15	F07	90	F05	70	14	11	18	ABCDEFHGKMN	9.92
80	47	128	140	70	126	78	65.9	22	F10	125	F07	102	18	14	23	ABCDEFHGKMN	15.43
100	53	150	157	70	153	95	93	25	F10	125	F07	102	18	14	23	ABCDEFHGKMN	19.84
125	57	163	170	70	184	118	120	36	F10	125	F07	102	22	17	23	ABCDEFHGKMN	26.45
150	56	176	185	70	212	143	149	50	F10	125	F07	102	22	17	23	ACDEFKMNP	29.76
200	62	206	220	80	268	188	196	70	F12	150	F10	125	25	19	28	ACDEFKMNP	48.50
250	68	238	260	80	326	236	243	90	F12	150	F10	125	28	22	28	ACDEFKMNP	70.54
300	78	269	290	100	375	282	289	106	F14	175	F12	160	35	27	37	ACDEFKMNP	105.82
350	78/92	306	326	100	416	322	329	125	F14	175	F12	160	36	27	37	ACDEFKMNP	145.50
400	102	342	370	120	476	371	377	140	F16	210	F14	195	48	36	47	ACDEFKMNP	235.89
450	114	370	395	120	534	418	423	157	F16	210	F14	195	48	36	47	ACDEFKMNP	286.60
500	127	399	430	120	588	466	471	177	F16	210	F14	195	60	46	56	ACDEFKMNP	359.35
600	154	455	490	150	692	570	572	210	F25	300	-	300	60	46	56	ACDEFKMN	612.88
600	154	455	490	150	692	570	572	210	F25	300	-	300	60	46	56	ACDEFKMN	612.88

A: 150LB B:300LB C:PN10 D:PN16 E: PN20 F:PN25 G:PN40 H:PN50 K:10K M:16K N: B.S. 10 TABLE E P:20K
Pipe limit size > C

Wafer type dimension [inch]

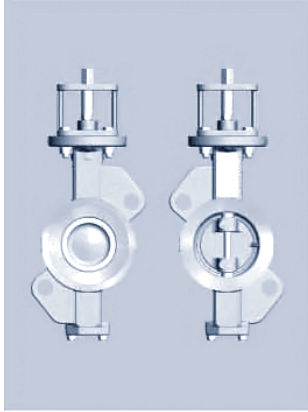

Size: 2" to 3"

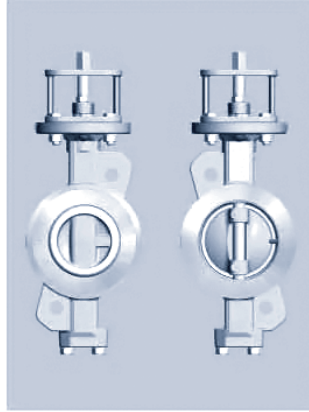

Size: 4" to 5"

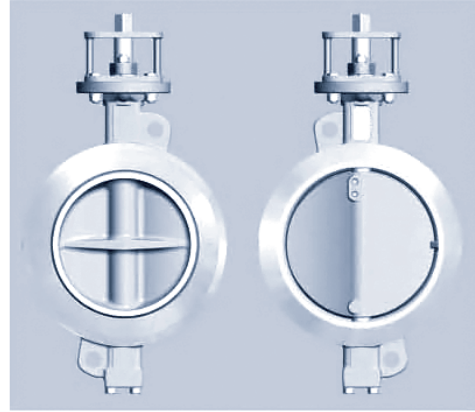

Size: 6" to 12"

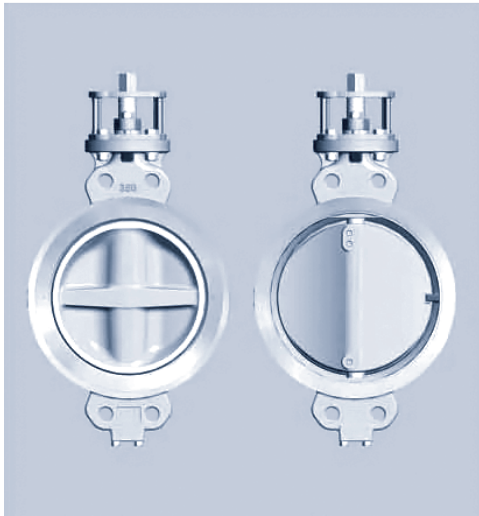

Size: 14" to 20"

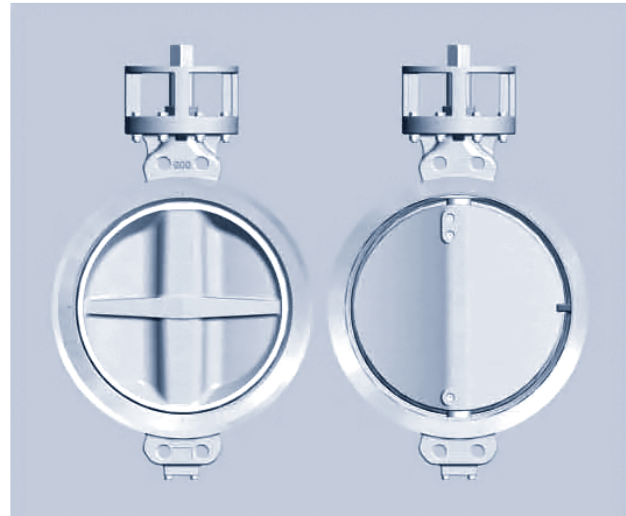

Size: 24"

Size	Face to face	Dimensions							Mounting flange (ISO 5211)				Shaft end			Weight	
		L	H1	H2	H3	∅D	∅D1	C	C1	Valve		Yoke		M1	∅B		□B
inch	L	H1	H2	H3	∅D	∅D1	C	C1	Type	∅M	Type	M1	∅B	□B	B1	lbs.	
2"	1.69	3.90	4.65	2.36	3.62	1.46	1.95	0.08	F07	3.54	F07	F05	2.76	0.55	0.43	0.71	9
2½"	1.81	4.33	4.92	2.36	4.25	2.48	2.45	0.59	F07	3.54	F07	F05	2.76	0.55	0.43	0.71	10
3"	1.85	5.04	5.51	2.76	4.96	3.07	2.59	0.87	F10	4.92	F10	F07	4.02	0.71	0.55	0.91	15
4"	2.09	5.91	6.18	2.76	6.02	3.74	3.66	0.98	F10	4.92	F10	F07	4.02	0.71	0.55	0.91	20
5"	2.24	6.42	6.69	2.76	7.24	4.65	4.72	1.42	F10	4.92	F10	F07	4.02	0.87	0.67	0.91	26
6"	2.20	6.93	7.28	2.76	8.35	5.63	5.87	1.97	F10	4.92	F10	F07	4.02	0.87	0.67	0.91	30
8"	2.44	8.11	8.66	3.15	10.55	7.39	7.72	2.76	F12	5.91	F12	F10	4.90	0.98	0.75	1.10	48
10"	2.68	9.37	10.24	3.15	12.83	9.27	9.57	3.54	F12	5.91	F12	F10	4.92	1.10	0.87	1.10	70
12"	3.07	10.59	11.42	3.94	14.76	11.10	11.38	4.17	F14	6.89	F14	F12	6.30	1.38	1.06	1.46	106
14"	3.07/3.62	12.05	12.83	3.94	16.38	12.68	12.95	4.92	F14	6.89	F14	F12	6.30	1.42	1.06	1.46	145
16"	4.02	13.46	14.57	4.72	18.74	14.61	14.84	5.51	F16	8.27	F16	F14	7.68	1.89	1.42	1.85	236
18"	4.49	14.57	15.55	4.72	21.02	16.46	16.65	6.18	F16	8.27	F16	F14	7.68	1.89	1.42	1.85	286
20"	5.00	15.71	16.93	4.72	23.15	18.35	18.54	6.97	F16	8.27	F16	F14	7.68	2.36	1.81	2.20	359
24"	6.06	17.91	19.29	5.91	27.24	22.44	22.52	8.27	F25	11.81	F16	-	11.81	2.36	1.81	2.20	612
24"	6.06	17.91	19.29	5.91	27.24	22.44	22.52	8.27	F25	11.81	F25	-	11.81	2.36	1.81	2.20	612

Pipe limit size > C

Lug type dimension [mm]

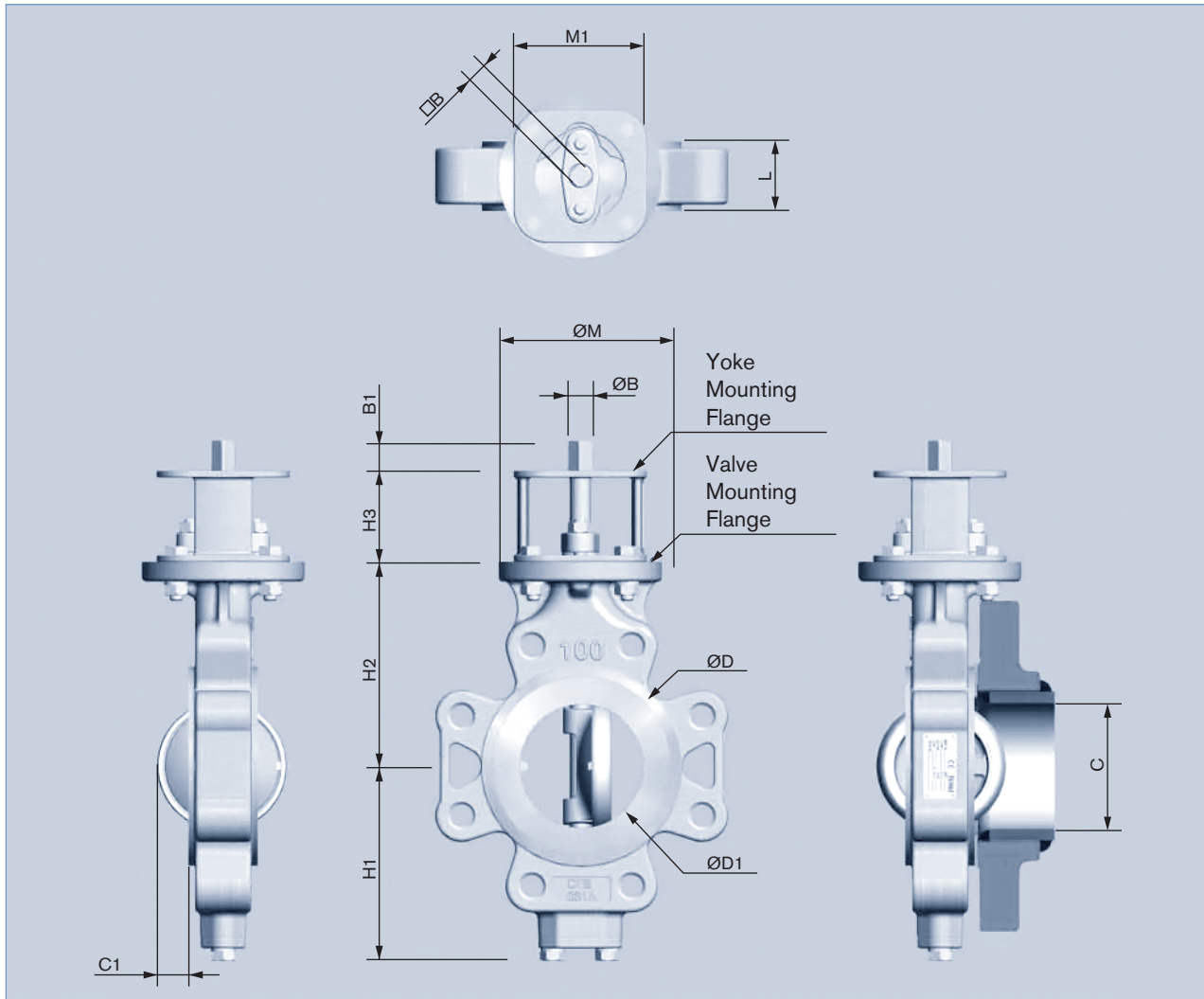

Size	Face to face	Dimensions							Mounting flange (ISO 5211)				Shaft end			Suitable pipe flange	Weight	
		L	H1	H2	H3	ØD	ØD1	C	C1	Valve Type	ØM	Yoke Type	M1	ØB	B			B1
50	43	99	118	60	92	37	49.5	2	F07	90	F07	F05	70	14	11	18	ACDEFKN	10.80
65	46	110	125	60	108	63	62.3	15	F07	90	F07	F05	70	14	11	18	ABCDEFGHIKMN	12.12
80	47	128	140	70	126	78	65.9	22	F10	125	F10	F07	102	18	14	23	ABCDEFGHIKMN	18.73
100	53	150	127	70	153	95	93	25	F10	125	F10	F07	102	18	14	23	ABCDEFGHIKMN	30.86
125	57	163	170	70	184	118	120	36	F10	125	F10	F07	102	22	17	23	ABCDEFGHIKMN	39.68
150	56	176	185	70	212	143	149	50	F10	125	F10	F07	102	22	17	23	ACDEFKMNP	42.99
200	62	206	220	80	268	188	196	70	F12	150	F12	F10	125	25	19	28	ACDEFKMNP	68.34
250	28	238	260	80	326	236	243	90	F12	150	F12	F10	125	28	22	28	ACDEFKMNP	103.61
300	78	269	290	100	282	282	289	106	F14	175	F14	F12	160	35	27	37	ACDEFKMNP	147.71
350	78/92	306	326	100	322	322	329	125	F14	175	F14	F12	160	36	27	37	ACDEFKMNP	178.57
400	102	342	370	120	371	371	377	140	F16	210	F16	F14	195	48	36	47	ACDEFKMNP	315.26
450	114	370	395	120	418	418	423	157	F16	210	F16	F14	195	48	36	47	ACDEFKMNP	359.35
500	127	399	460	120	466	466	471	177	F16	210	F16	F14	195	60	46	56	ACDEFKMNP	507.06
600	154	455	490	150	570	570	572	210	F25	300	F16	-	300	60	46	56	ACDEF	831.14
600	154	455	490	150	570	570	572	210	F25	300	F25	-	300	60	46	56	ACDEF	831.14

A:150LB B:300LB C:PN10 D:PN16 E:PN20 F:PN25 G:PN40 G:PN40 H:PN50 K:10K M:16K N:B.S. 10 TABLE E P:20K
Pipe limit size > C

Lug type dimension [inch]

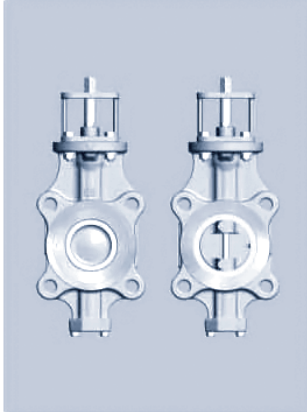

Size: 2" to 3"

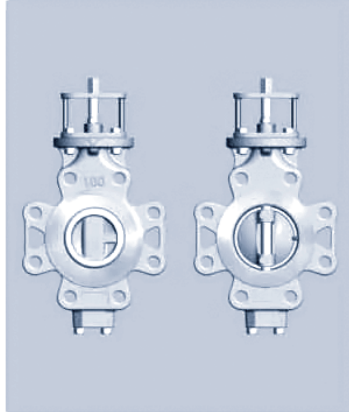

Size: 4" to 5"

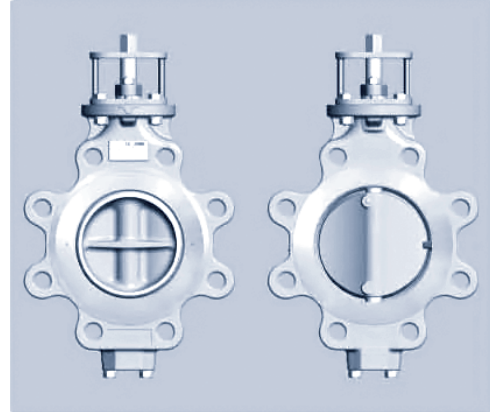

Size: 6" to 8"

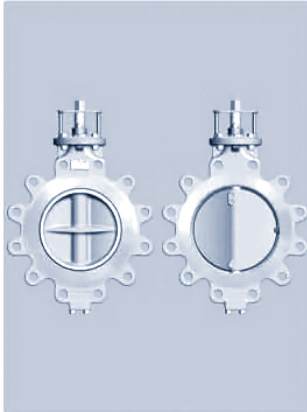

Size: 10" to 14"



Size: 16" to 18"

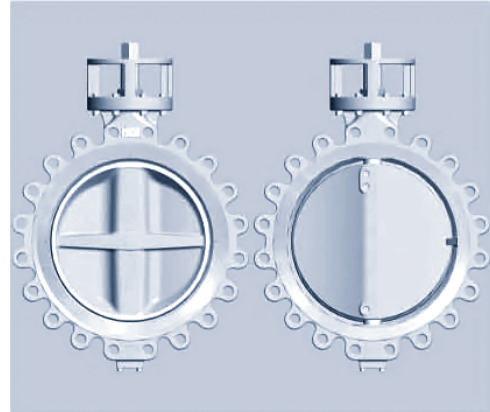

Size: 20" to 24"

Size	Face to face	Dimensions							Mounting flange (ISO 5211)				Shaft end			Weight	
		L	H1	H2	H3	∅D	∅D1	C	C1	Valve Type	∅M	Yoke Type	M1	∅B	□B		B1
2"	1.69	3.90	4.65	2.36	3.62	1.46	1.95	0.08	F07	3.54	F07	F05	2.76	0.55	0.43	1.71	10
2½"	1.81	4.33	4.92	2.36	4.25	2.48	2.45	0.59	F07	3.54	F07	F05	2.76	0.55	0.43	0.71	12
3"	1.85	5.04	5.51	2.76	4.96	3.07	3.07	0.87	F10	4.92	F10	F07	4.02	0.71	0.55	0.91	19
4"	2.09	5.91	6.18	2.76	6.02	3.74	3.66	0.98	F10	4.92	F10	F07	4.02	0.71	0.55	0.91	31
5"	2.24	6.42	6.69	2.76	7.24	4.65	4.72	1.42	F10	4.92	F10	F07	4.02	0.87	0.67	0.91	40
6"	2.20	6.93	7.28	2.76	8.35	5.63	5.87	1.97	F10	4.92	F10	F07	4.02	0.87	0.67	0.91	43
8"	2.44	8.11	8.66	3.15	10.55	7.39	7.72	2.76	F12	5.91	F12	F10	4.90	0.98	0.75	1.10	68
10"	2.68	9.37	10.24	3.15	12.83	9.27	9.57	3.54	F12	5.91	F12	F10	4.92	1.10	0.87	1.10	104
12"	3.07	10.59	11.42	3.94	14.76	11.10	11.38	4.17	F14	6.89	F14	F12	6.30	1.38	1.06	1.46	148
14"	3.07/3.62	12.05	12.83	3.94	16.38	12.68	12.95	4.92	F14	6.89	F14	F12	6.30	1.42	1.06	1.46	178
16"	4.02	13.46	14.57	4.72	18.74	14.61	14.84	5.51	F16	8.27	F16	F14	7.68	1.89	1.42	1.85	315
18"	4.49	14.57	15.55	4.72	21.02	16.46	16.65	6.18	F16	8.27	F16	F14	7.68	1.89	1.42	1.85	359
20"	5.00	15.71	16.93	4.72	23.15	18.35	18.54	6.97	F16	8.27	F16	F14	7.68	2.36	1.81	2.20	507
24"	6.06	17.91	19.29	5.91	27.24	22.44	22.52	8.27	F25	11.81	F16	-	11.81	2.36	1.81	2.20	830
24"	6.06	17.91	19.29	5.91	27.24	22.44	22.52	8.27	F25	11.81	F25	-	11.81	2.36	1.81	2.20	830

Pipe limit size > C

Lever & gear operated

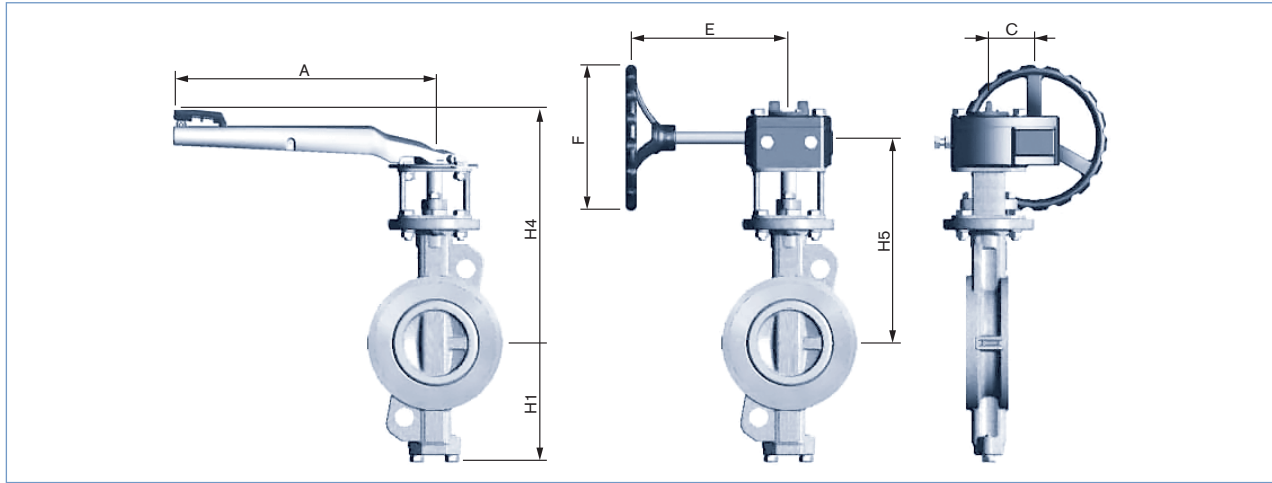

Size		Lever operator				Gear operator					
mm	inch	Dimensions [mm]		Weight [lbs.]		Dimensions [mm]				Weight [lbs.]	
		H4	L	Wafer	Lug	H5	C	E	F	Wafer	Lug
50	2"	250	200	10.8	12	215	41	155	150	16	18
65	2½"	257	200	11	14	222	41	155	150	17	19
80	3"	282	250	17	20	247	41	155	200	23	26
100	4"	299	250	22	33	268.5	63	195	200	36	47
125	5"	318	355	30	43	281.5	63	195	200	43	56
150	6"	333	355	33	46	296.5	63	195	200	46	59
200	8"	378	335	52.03	71.87	341	61	255	310	68	88
250	10"	-	-	-	-	381	61	255	310	90	123
300	12"	-	-	-	-	443	81	340	400	154	196
350	14"	-	-	-	-	479	81	340	400	194	227
400	16"	-	-	-	-	546	123	307	400	302	381
450	18"	-	-	-	-	571	123	307	400	352	425
500	20"	-	-	-	-	606	123	307	400	425	573
600	24"	-	-	-	-	692	123	307	400	672	891
						785	160	370	400	760	978

Size		Lever operator				Gear operator						Hand-wheel turns	Mounting flange (ISO 5211)		
mm	inch	Dimensions [inch]		Weight [lbs.]		Dimensions [inch]				Weight [lbs.]		On/Off	Type	PCD	
		H4	L	Wafer	Lug	H5	C	E	F	Wafer	Lug	N		mm	inch
50	2"	9.84	7.87	10.8	12	8.46	1.61	6.10	5.91	16	18	10	F07	70	2.76"
65	2½"	10.19	7.87	11	14	8.74	1.61	6.10	5.91	17	19	10	F07	70	2.76"
80	3"	11.10	9.84	17	20	9.72	1.61	6.10	5.91	23	26	10	F07	70	2.76"
100	4"	11.77	9.84	22	33	10.57	2.48	7.68	7.87	36	47	9	F10	102	4.02"
125	5"	12.52	13.98	30	43	11.08	2.48	7.68	7.87	43	56	9	F10	102	4.02"
150	6"	13.11	13.98	33	46	11.67	2.48	7.68	7.87	46	59	9	F10	102	4.02"
200	8"	14.88	13.98	52.03	71.87	13.43	2.40	10.04	12.20	68	88	9.5	F12	125	4.92"
250	10"	-	-	-	-	15.00	2.40	10.04	12.20	90	123	9.5	F12	125	4.92"
300	12"	-	-	-	-	17.44	3.19	13.39	15.75	154	196	12	F14	140	5.51"
350	14"	-	-	-	-	18.86	3.19	13.39	15.75	194	227	12	F14	140	5.51"
400	16"	-	-	-	-	21.50	4.84	12.09	15.75	302	381	17.5	F16	165	6.50"
450	18"	-	-	-	-	22.48	4.84	12.09	15.75	352	425	17.5	F16	165	6.50"
500	20"	-	-	-	-	23.86	4.84	12.09	15.75	425	573	17.5	F16	165	6.50"
600	24"	-	-	-	-	27.24	4.84	12.09	15.75	672	891	17.5	F16	165	6.50"
						30.91	6.30	14.57	15.75	760	978	52.5	F25	254	10.00"

Bolting & gasket for installation [mm]

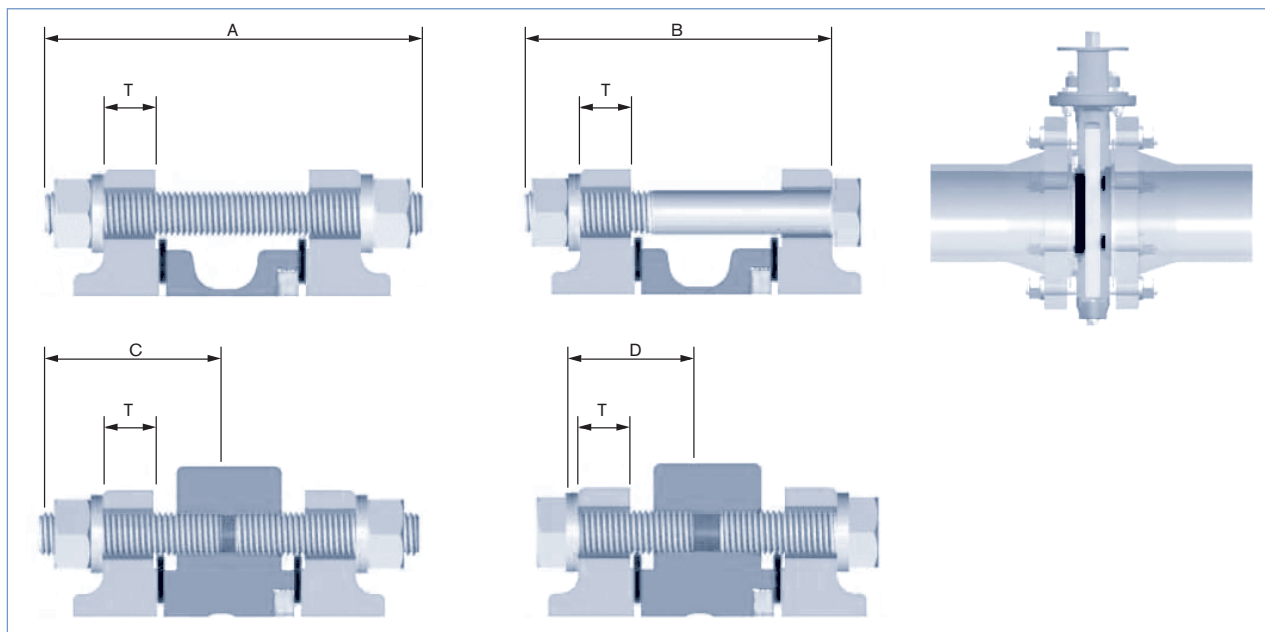

Size		PN10						PN16					
mm	inch	Bolt size	A	B	C	D	T	Bolt size	A	B	C	D	T
50	2"	M16	130	120	65	45	20	M16	130	120	65	45	20
65	2½"	M16	130	120	65	45	20	M16	130	120	65	45	20
80	3"	M16	135	120	65	45	20	M16	135	120	65	45	20
100	4"	M16	145	130	70	50	22	M16	145	130	70	50	22
125	5"	M16	145	135	75	50	22	M16	145	135	75	50	22
150	6"	M20	160	140	80	55	24	M20	160	140	80	55	24
200	8"	M20	160	145	80	55	24	M20	160	145	80	55	24
250	10"	M20	175	160	85	60	26	M24	185	165	85	60	26
300	12"	M20	185	170	90	65	26	M24	200	180	90	70	28
350	14"	M20	185	170	90	65	26	M24	200	185	90	70	30
400	16"	M24	220	200	110	70	26	M27	235	215	110	80	32
450	18"	M24	235	215	115	75	28	M27	265	240	115	90	40
500	20"	M24	245	230	125	75	28	M30	295	270	125	100	44
600	24"	M27	290	270	145	85	34	M33	345	320	145	110	54

Size		PN20						PN25					
mm	inch	Bolt size	A	B	C	D	T	Bolt size	A	B	C	D	T
50	2"	M16	135	125	70	50	22.5	M16	135	125	70	50	22
65	2½"	M16	135	125	70	50	23	M16	135	125	70	50	22
80	3"	M16	140	130	70	50	24	M16	140	130	70	50	24
100	4"	M16	145	135	75	55	24	M20	155	140	80	55	24
125	5"	M20	155	140	75	55	24	M24	175	155	85	60	26
150	6"	M20	160	145	80	55	26	M24	175	155	90	60	28
200	8"	M20	170	155	85	60	29	M24	185	165	90	65	30
250	10"	M24	195	175	95	70	31	M27	200	180	100	70	32
300	12"	M24	205	185	105	70	32	M27	215	195	110	75	34
350	14"	M27	220	195	105	75	35	M30	230	205	115	80	38
400	16"	M27	245	225	125	85	37	M33	265	240	130	95	40
450	18"	M30	270	240	130	95	40	M33	290	265	145	105	48
500	20"	M30	290	265	140	95	43	M33	305	280	155	105	48
600	24"	M33	335	310	165	105	48	M36	360	330	180	120	58

Bolting & gasket for installation [mm] (continued...)

Size		ANSI B16.5 150LB						JIS10K					
mm	inch	Bolt size	A	B	C	D	T	Bolt size	A	B	C	D	T
50	2"	5/8"	135	125	70	50	20	M16	130	115	65	45	16
65	2½"	5/8"	135	125	70	50	22	M16	130	115	65	45	18
80	3"	5/8"	140	130	70	50	24	M16	130	115	65	45	18
100	4"	5/8"	145	135	75	55	24	M16	135	120	70	50	18
125	5"	¾"	160	145	80	55	24	M20	150	135	75	55	20
150	6"	¾"	160	145	80	55	25	M20	155	140	80	55	22
200	8"	¾"	170	155	85	60	28	M20	160	140	80	55	22
250	10"	7/8"	185	170	95	65	30	M22	175	155	85	60	24
300	12"	7/8"	200	180	100	70	32	M22	185	165	90	60	24
350	14"	1"	215	195	105	75	35	M22	190	170	95	65	26
400	16"	1"	240	220	120	80	37	M24	220	205	110	70	28
450	18"	1 1/8"	265	240	130	90	40	M24	240	220	120	75	30
500	20"	1 1/8"	285	260	140	90	43	M24	250	230	125	75	30
600	24"	1 ¼"	330	305	165	100	48	M30	295	270	145	85	32

Size		JIS 16K & 20K						B.S. 10 Table E					
mm	inch	Bolt size	A	B	C	D	T	Bolt size	A	B	C	D	T
50	2"	M16	130	115	65	45	16	5/8"	120	110	60	40	10
65	2½"	M16	130	115	65	45	18	5/8"	120	110	60	40	14
80	3"	M20	140	125	70	50	20	5/8"	120	110	60	40	14
100	4"	M20	150	135	75	55	22	5/8"	135	120	65	45	17
125	5"	M22	160	140	80	55	22	5/8"	140	125	70	50	17
150	6"	M22	160	145	80	55	24	¾"	145	130	70	50	17
200	8"	M22	170	150	85	60	26	¾"	152	135	75	50	19
250	10"	M24	190	170	95	65	28	¾"	165	150	85	55	22
300	12"	M24	200	185	100	70	30	7/8"	185	170	95	65	25
350	14"	M30	220	200	110	80	34	7/8"	195	175	95	70	29
400	16"	M30	255	230	130	85	38	7/8"	225	205	110	75	32
450	18"	M30	270	245	135	90	40	7/8"	240	225	120	80	35
500	20"	M30	290	265	145	95	42	7/8"	260	245	130	80	38
600	24"	M36	335	310	170	105	46	1 1/8"	325	300	165	100	48

High performance butterfly valve specification chart

Size	Type	Style	Body	Seat	Disc	Stem	Operator	Limit Switch	Solenoid	Positioner
4.0"	2	1	3	8	1	1	1	A	0	A
2.5"	2-high performance	1-wafer	3-316SS	8-PTFE	1-316SS	1-410SS	0-bare stem	A-none	0-none	A-none
3.0"		2-lung	4-carbon steel	9-graphite	2-304SS	2-304SS	1-10 position handle	B-SPDT	1-120/1/60 VAC	B-4-20 Ma
4.0"			5-304SS			3-316SS	2-gear operator	S-please specify	2-24 VDC	
5.0"							3-pneumatic D/A			
6.0"							4-pneumatic S/R F/C			
8.0"							5-pneumatic S/R F/O			
10.0"							6-electric 120 VAC			
12.0"							7-electric 24 VDC			
14.0"										
16.0"										
18.0"										
20.0"										
24.0"										

Notes:

Flange Class ANSI 150

D/A = Double Acting

S/R = Spring Acting

F/O = Fail Open

F/C = Fail Closed

See electric actuator datasheet for complete options.

