

По вопросам продаж и поддержки обращайтесь:

Архангельск (8182)63-90-72	Краснодар (861)203-40-90	Рязань (4912)46-61-64
Астана (7172)727-132	Красноярск (391)204-63-61	Самара (846)206-03-16
Белгород (4722)40-23-64	Курск (4712)77-13-04	Санкт-Петербург (812)309-46-40
Брянск (4832)59-03-52	Липецк (4742)52-20-81	Саратов (845)249-38-78
Владивосток (423)249-28-31	Магнитогорск (3519)55-03-13	Смоленск (4812)29-41-54
Волгоград (844)278-03-48	Москва (495)268-04-70	Сочи (862)225-72-31
Вологда (8172)26-41-59	Мурманск (8152)59-64-93	Ставрополь (8652)20-65-13
Воронеж (473)204-51-73	Набережные Челны (8552)20-53-41	Тверь (4822)63-31-35
Екатеринбург (343)384-55-89	Нижний Новгород (831)429-08-12	Томск (3822)98-41-53
Иваново (4932)77-34-06	Новокузнецк (3843)20-46-81	Тула (4872)74-02-29
Ижевск (3412)26-03-58	Новосибирск (383)227-86-73	Тюмень (3452)66-21-18
Казань (843)206-01-48	Орел (4862)44-53-42	Ульяновск (8422)24-23-59
Калининград (4012)72-03-81	Оренбург (3532)37-68-04	Уфа (347)229-48-12
Калуга (4842)92-23-67	Пенза (8412)22-31-16	Челябинск (351)202-03-61
Кемерово (3842)65-04-62	Пермь (342)205-81-47	Череповец (8202)49-02-64
Киров (8332)68-02-04	Ростов-на-Дону (863)308-18-15	Ярославль (4852)69-52-93

Единый адрес: btk@nt-rt.ru **Веб-сайт:** www.burkert.nt-rt.ru

МЕМБРАННЫЕ КЛАПАНЫ



Tank bottom diaphragm valve with hand actuator

- Valve housing and diaphragm available in various materials and designs
- Surfaces in contact with the product from $Ra \leq 0.38 \mu\text{m} \dots 1.6 \mu\text{m}$ (optionally electropolished)
- Available in all common connection sizes and variants



Product variants described in the data sheet may differ from the product presentation and description.

Can be combined with

	Type 2034 Multifunction block and weld solution
	Type 2031 2/2 way diaphragm valve with pneumatic plastic actuator (Type CLASSIC)
	Type 2063 2/2 way diaphragm valve with pneumatic actuator in stainless steel (Type INOX)
	Type 2036 Robolux multiway multiport diaphragm valve, pneumatically operated
	Type 8036 INLINE flowmeter with paddle wheel, ELEMENT design

Type description

The manually operated diaphragm valve, Type 3235, consists of a manually operated actuator, a diaphragm and a tank bottom valve housing. The manual actuator with either a plastic or stainless steel handwheel ensures use under hygienic or aggressive environmental conditions. The flow-efficient valve housing with little dead space enables high flow rates and a wide range of possible uses. The valve housing and the diaphragm are available in all common materials and designs. The actuator has a compact, autoclavable design and is compatible with all other Bürkert diaphragm valves. An explosion-proof ATEX/IECEX device variant is available.

The add-on housing and the handwheel are available in plastic or stainless steel and are equipped with an integrated optical position indicator. In addition, the manual actuator can be equipped with a stroke limiter, sensors for position feedback and a locking function.

1. General technical data

Product properties	
Dimensions	Detailed information can be found in chapter "4. Dimensions" on page 6.
Material^{1.)}	
Block body (VH) ^{1.)}	Stainless steel 1.4435/316 L
Block body (VI) ^{1.)}	Stainless steel 1.4435/BN2/ASME BPE; Fe < 0.5 %/C ≤ 0.03 %
Diaphragm	EPDM (AD) ^{1.)} , PTFE/EPDM (EA) ^{1.)} , advanced PTFE/EPDM (EU) ^{1.)} , Gylon®/EPDM laminated (ER) ^{1.)}
Actuator (Actuator/handwheel) - Diaphragm size 8...50	PPS (Stainless steel on request)/PPS (Stainless steel on request)
Actuator (Actuator/handwheel) - Diaphragm size 65...100	Stainless steel/Stainless steel
Diaphragm size	8...100
Standard surface quality^{2.)}	
Block body (VH/VI) ^{1.)}	Internal electrically polished : Ra ≤ 0.38 µm (NO17) ^{1.)} (ASME BPE SF4/DIN HE4) (external Ra ≤ 1.6 µm) Internal mechanically polished : Ra ≤ 0.5 µm (NO14) ^{1.)} (ASME BPE SF1) (external Ra ≤ 1.6 µm)
Medium data	
Medium	Neutral gases and fluids, highly purified, sterile, aggressive or abrasive medium (see Resistance Chart ▶)
Medium temperature	
EPDM (AD) ^{1.)}	-10...+143 °C (steam sterilisation + 150 °C for 60 min)
PTFE/EPDM (EA) ^{1.)}	-10...+130 °C (steam sterilisation + 140 °C for 60 min)
advanced PTFE/EPDM (EU) ^{1.)}	-5...+143 °C (steam sterilisation + 150 °C for 60 min)
GYLON®/EPDM laminated (ER) ^{1.)}	-5...+130 °C (steam sterilisation + 140 °C for 60 min)
Process/Port connection & communication	
Nominal diameter	DN06...DN100 (1/8" ... 4")
Port connections^{2.)}	
Welded connection ^{2.)}	DIN EN ISO 1127/ISO 4200/DIN 11866 series B DIN 11850 series 2/DIN 11866 series A/DIN EN 10357 series A ASME BPE/DIN 11866 series C
Clamp connection ^{2.)}	DIN 32676 series A (DIN pipe) DIN 32676 series B (ISO pipe) ASME BPE
Environment and installation	
Installation position	See operating manual ▶
Ambient temperature	
PPS/PPS	0...+130 °C (short-term up to +150 °C)
Stainless steel/PPS	0...+130 °C (short-term up to +150 °C)
Stainless steel/Stainless steel	-10...+140 °C (short-term up to +150 °C)

1.) This information is part of the product key (see product enquiry form at the end of this data sheet)

2.) Further versions on request

2. Approvals

Note:

If you need one of these certificates, please contact your Bürkert partner.

Approvals/ Conformity/ Certificate ^{1.)}	Description
	ATEX/IECEX^{2.)} EPS 18 ATEX 2 008 X II 2G Ex h IIC T4 Gb/II 2D Ex h IIIC T135 °C Db IECEX EPS 18.0007X Ex h IIC T4 Gb/Ex h IIIC T135 °C Db
TA-Air	TA-Air ^{3.)}
	3-A (3-A Sanitary Standards Symbol Administrative Council) ^{4.)}
	The diaphragms made of EPDM (AD), PTFE/EPDM (EA), advanced PTFE/EPDM (EU) and GYLON®/EPDM laminated (ER) are suitable for use with food and beverages (acc. to EC Regulation 1935/2004/EC).
	Diaphragms made of EPDM (AD), PTFE/EPDM (EA), advanced PTFE/EPDM (EU) and GYLON®/EPDM laminated (ER) are acc. to USP Class VI tested.
FDA	Diaphragms made of EPDM (AD), PTFE/EPDM (EA), advanced PTFE/EPDM (EU) and GYLON®/EPDM laminated (ER) comply with the Code of Federal Regulations published by the FDA (Food and Drug Administration, USA).

1.) Further approvals/conformity clarification on request

2.) Only in combination with variable code «PX51» (see product enquiry form at the end of this data sheet)

3.) Only in combination with variable code «PM01» (see product enquiry form at the end of this data sheet)

4.) Only in combination with variable code «PE05» (see product enquiry form at the end of this data sheet)

3. Materials

3.1. Chemical Resistance Chart – Bürkert resistApp

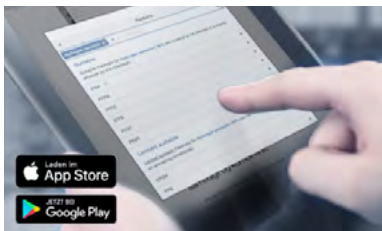

Bürkert resistApp – Chemical Resistance Chart

You want to ensure the reliability and durability of the materials in your individual application case? Verify your combination of media and materials on our website or in our resistApp.

[Start Chemical Resistance Check](#)

3.2. Material specifications

Note:

Your product variant may differ from this illustration depending on the housing and interface options.

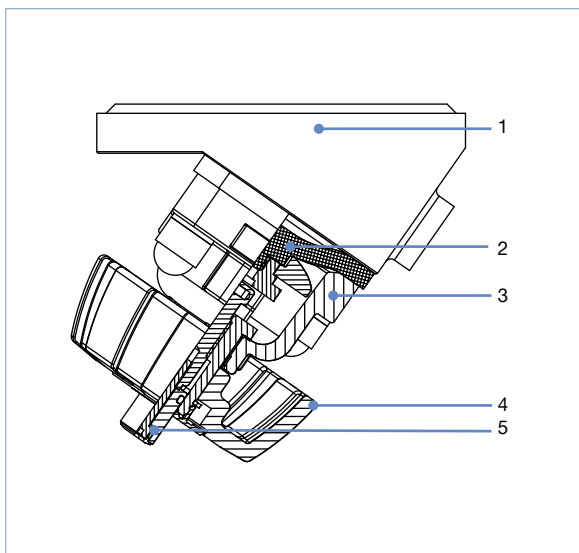

No.	Element	Material
1	Valve body	See “1. General technical data” on page 3
2	Diaphragm	EPDM (AD), PTFE/EPDM (EA), advanced PTFE/EPDM (EU), Gylon®/EPDM laminated (ER)
3	Actuator	Diaphragm size 8...50: polyphenylene sulphide PPS (stainless steel on request) Diaphragm size 65...100: stainless steel
4	Handwheel	Diaphragm size 8...50: polyphenylene sulphide PPS (stainless steel on request) Diaphragm size 65...100: stainless steel
5	Optical position indicator	Diaphragm size 15...50: polyoxymethylene Diaphragm size 65...100: stainless steel

3.3. Example of available membrane materials

The diaphragms have been developed to meet the unique challenges of hygienic and sterile requirements. Bürkert offers diaphragms with precise material composition and high accuracy. Bürkert diaphragms are available in a wide range of materials which have been tested and proven in applications in the food and beverage, biotechnology, pharmaceutical and cosmetics industries. The diaphragms are tested during development and production to ensure reliability under difficult process conditions.



- EPDM (AD)
- PTFE/EPDM (EA)
- advanced PTFE/EPDM (EU)
- Gylon®/EPDM laminated (ER)

For further information please refer to our flyer “Diaphragm competence for hygienic applications” on our [website](#) ▶.

4. Dimensions

4.1. Actuator

Handwheel

Note:

Dimensions in mm, unless otherwise stated

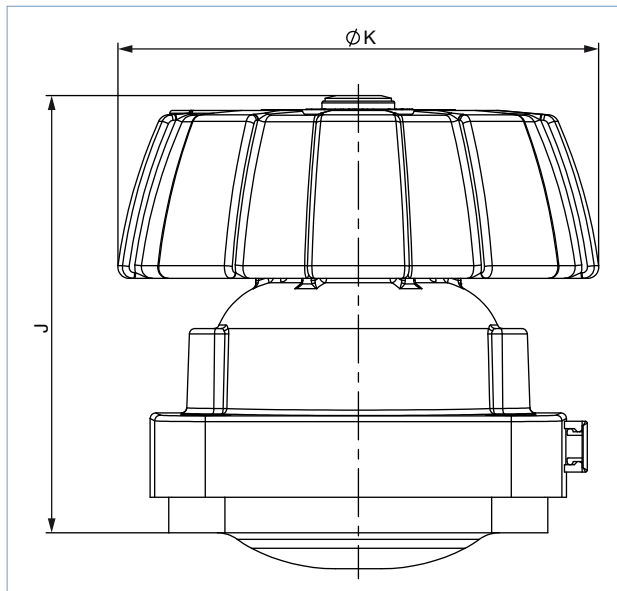

Diaphragm size	ØK	J
8	35	48
15	85	74
20	86	82
25	86	78
32	114	101
40	114	100
50	114	117
65	272	188
80	272	196
100	272	207

Hand wheel with tank bottom body

Note:

Dimensions in mm, unless otherwise stated

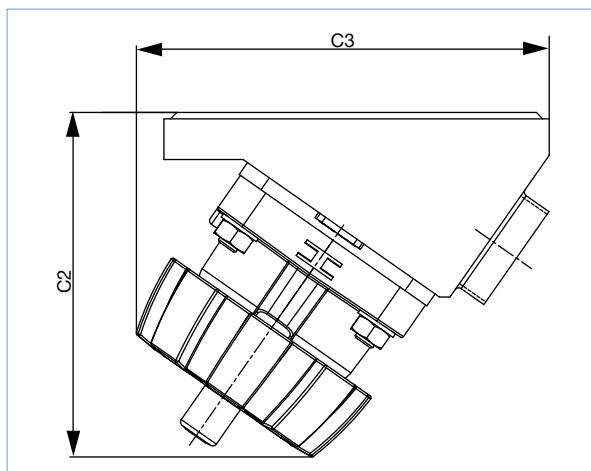

Diaphragm size	C2	C3
8	66	67
15	103	106
20	113	117
25	110	124
40	149	177
50	163	192
65	265	305
80	336	278
100	300	370

4.2. Tank bottom body with welded connection

Note:

Dimensions in mm, unless otherwise stated

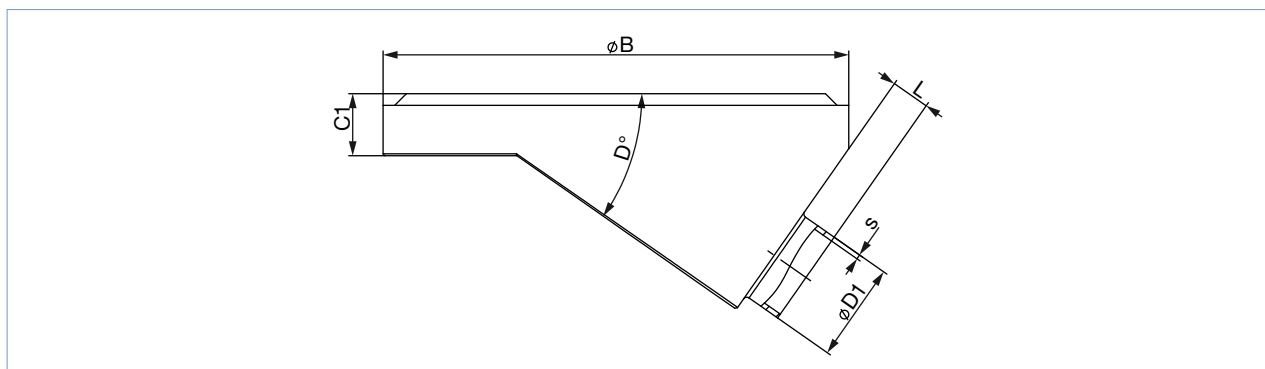

Diaphragm size	Port connection DN	ØB	C1	D	ØA	s	L	Product key ^{1.)}
DIN EN ISO 1127/ISO 4200/DIN 11866 series B								
8	8	50	8	35°	13.5	1.6	5	SA40
15	15	65	12	35°	21.3	1.6	4	SA42
		85					8	SA42
20	20	85	12	35°	26.9	1.6	5.6	SA43
25	25	120	16	35°	33.7	2	8	SA44
40	32	150	18	35°	42.4 (Port 32)	2	20	SA45
	40				48.3		15	SA46
50	50	180	22	35°	60.3	2	12	SA47
80	65	225	20	40°	76.1	2	16	SA48
	80				88.9	2.3	10	SA49
100	100	298	30	40°	114.3	2.3	16.5	SA39
DIN 11850 series 2/DIN 11866 series A/DIN EN 10357 series A								
8	10	50	8	35°	13	1.5	5	SD40
15	15	85	12	35°	19	1.5	8	SD42
20	20	85	12	35°	23	1.5	7	SD43
25	25	120	16	35°	29	1.5	8	SD44
40	40	150	18	35°	41	1.5	20	SD46
50	50	180	22	35°	53	1.5	15	SD47
80	80	225	20	40°	85	2	16	SD49
100	100	298	30	40°	104	2	14	SD50
ASME BPE/DIN 11866 series C								
8	¼"	50	8	35°	6.35	0.89	6	SA90
15	½"	85	12	35°	12.7	1.65	10	SA92
20	¾"	85	12	35°	19.05	1.65	8	SA93
25	1"	120	16	35°	25.4	1.65	12	SODF
40	1½"	150	18	35°	38.1	1.65	15	SODH
	1½"				38.1		25	SODH
					2"		50.8	15
80	2½"	225	20	40°	63.5	1.65	11	SODJ
	2½"				63.5		25	SODJ
	3"				76.2		16	SODK
100	4"	298	30	40°	101.6	2.11	14	SODL
SMS 3008								
25	25	120	16	35°	25	1.2	8	SA60
40	40	150	18	35°	38	1.2	20	SA62
50	50	180	22	35°	51	1.2	15	SA63

1.) This information is part of the product key (see product enquiry form at the end of this data sheet)

4.3. Tank bottom body with clamp connection

Note:

Clamp dimensions must be added to the welded connection dimensions.

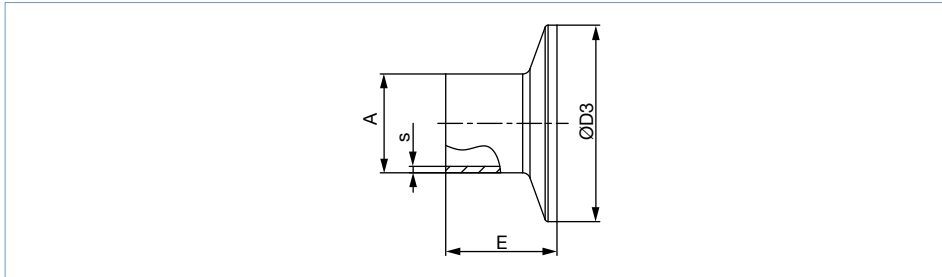

Port connection		A	s	D3	E	Product key ^{1.)}
[mm]	[inch]					
DIN 32676 series A (DIN pipe)						
10	–	13	1.5	34.0	18	TD41
15	–	19	1.5	34.0	18	TD42
20	–	23	1.5	34.0	18	TD43
25	–	29	1.5	50.5	21.5	TD44
32	–	35	1.5	50.5	21.5	TD45
40	–	41	1.5	50.5	21.5	TD46
50	–	53	1.5	64.0	21.5	TD47
DIN 32676 series B (ISO pipe)						
8	–	13.5	1.6	25.0	28.6	TC40
8	–	13.5	1.6	34.0 ^{2.)}	28.6	TC51 ^{2.)}
10	–	17.2	1.6	34.0 ^{2.)}	28.6	TC41 ^{2.)}
15	–	21.3	1.6	34.0 ^{2.)}	28.6	TC42 ^{2.)}
15	–	21.3	1.6	50.5	28.6	TC52
20	–	26.9	1.6	50.5	28.6	TC43
25	–	33.7	2	50.5	28.6	TC44
32	–	42.4	2	50.5 ^{2.)}	28.6	TC45 ^{2.)}
40	–	48.3	2	64.0	28.6	TC46
50	–	60.3	2	77.5	28.6	TC47
ASME BPE						
8	1/4"	6.35	0.89	25.0	28.6	TG50
10	3/8"	9.53	0.89	25.0	28.6	TG01
15	1/2"	12.7	1.65	25.0	28.6	TG02
20	3/4"	19.05	1.65	25.0	28.6	TG03
25	1"	25.4	1.65	50.5	28.6	TG04
40	1 1/2"	38.1	1.65	50.5	28.6	TG05
50	2"	50.8	1.65	64.0	28.6	TG06

1.) This information is part of the product key (see product enquiry form at the end of this data sheet)

2.) Deviating from the standard, because of different clamp outer diameter.

5. Performance specifications

5.1. Medium pressure

Diaphragm size DN	Actuator material	Max. operating pressure for seal material
		EPDM; PTFE/EPDM, advanced PTFE/EPDM, GYLON®/EPDM laminated Max. [bar]
8...80	Stainless steel/Stainless steel	10
100	Stainless steel/Stainless steel	6
8...50	Stainless steel/PPS	10
8...40	PPS/PPS	10
50	PPS/PPS	7

6. Ordering information

6.1. Bürkert eShop – Easy ordering and quick delivery



Bürkert eShop – Easy ordering and fast delivery

You want to find your desired Bürkert product or spare part quickly and order directly? Our online shop is available for you 24/7. Sign up and enjoy all the benefits.

[Order online now](#)

6.2. Bürkert product filter



Bürkert product filter – Get quickly to the right product

You want to select products comfortably based on your technical requirements? Use the Bürkert product filter and find suitable articles for your application quickly and easily.

[Try out our product filter](#)





6.3. Bürkert product enquiry form





Bürkert product enquiry form: Would you like to make a specific product enquiry based on your technical requirements? Please use our product enquiry form **at the end of this data sheet**. There you will find all the information relevant to your Bürkert contact person that will help us to process your enquiry in the best possible way.

Bürkert specification key: In our product enquiry form you will find a complete explanation of the composition of our specification key. You will find our product enquiry form **at the end of this data sheet**.

Specification key - Examples

2 way diaphragm valve					
Type 2030 ▶ CLASSIC with plastic body 	Type 2031 ▶ CLASSIC with stainless steel body 	Type 2063 ▶ INOX with stainless steel body 	Type 2103 ▶ ELEMENT with stainless steel or plastic body 	Type 3232 ▶ Manually operated with plastic body 	Type 3233 ▶ Manually operated with stainless steel body 

T-diaphragm valve			
Type 2032 ▶ CLASSIC T-valve 	Type 2064 ▶ INOX T-valve 	Type 2104 ▶ ELEMENT T-valve 	Type 3234 ▶ Manually operated T-valve 

Tank bottom diaphragm valve			
Type 2033 ▶ CLASSIC Tank bottom valve 	Type 2065 ▶ INOX Tank bottom valve 	Type 2105 ▶ ELEMENT Tank bottom valve 	Type 3235 ▶ Manually operated tank bottom valve 

	Type	Control function	Nominal diameter diaphragm	Diaphragm material	Body material	Port connection	Port connection	Actuator version	Actuator size	Pilot air port	Actuator	Variable	Variable	Variable
Key Feature	TYP	SF	DN	DWST	WKST	LTA1	LTA2	ANTA	ANTG	STLA	ANTR	VAR1	VAR2	VAR3
Key No. →	1	2	3	4	5	6	6	7	8	9	10	V1	V2	V3

2 way diaphragm valve														
Type 2030 CLASSIC	2030	A	20.0	AD	PV	KM26	-	C	E	-	-			
Type 2031 CLASSIC	2031	A	20.0	AD	VS	SA93	-	C	E	-	-	NK52	NO14	
Type 2063 INOX	2063	A	20.0	AD	VS	SA93	-	H	M	-	-	NK52	NO14	
Type 2103 ELEMENT	2103	A	20.0	AD	PV	KM26	-	G	M	FA01	-			
Type 2103 ELEMENT	2103	A	20.0	AD	VS	SA93	-	G	M	FA01	-	NK52	NO14	
Type 3232	3232	-	20.0	AD	PV	KM26	-	-	-	-	D050			
Type 3233	3233	-	20.0	AD	VS	SA93	-	-	-	-	D051	NK52	NO14	
T-diaphragm valve														
Type 2032 CLASSIC	2032	A	20.0	AD	VH	SODH	SA93	D	E	-	-	NK52	NO14	
Type 2064 INOX	2064	A	20.0	AD	VH	SODH	SA93	-	M	-	-	NK52	NO14	
Type 2104 ELEMENT	2104	A	20.0	AD	VH	SODH	SA93	-	M	FA01	-	NK52	NO14	
Type 3234	3234	-	20.0	AD	VH	SODH	SA93	-	-	-	D050	NK52	NO14	
Tank bottom diaphragm valve														
Type 2033 CLASSIC	2033	A	20.0	AD	VH	SA93	-	D	F	-	-	NK52	NO14	
Type 2065 INOX	2065	A	20.0	AD	VH	SA93	-	-	M	-	-	NK52	NO14	
Type 2105 ELEMENT	2105	A	20.0	AD	VH	SA93	-	-	M	FA01	-	NK52	NO14	
Type 3235	3235	-	20.0	AD	VH	SA93	-	-	-	-	D050	NK52	NO14	

1.) NK52, NOxx only for stainless steel bodies

DTS 1000450621 EN Version: A Status: RL (released | freigegeben | valide) printed: 18.02.2021

Key Legend

Note:

- Other versions on request
- Available Type sizes see corresponding data sheet

Key no. 2: Control function (SF)				Key no. 8: Actuator size (ANTG)	
A	Closed with spring force			B	ø 32
B	Open with spring force			C	ø 40
I	Without pressure spring			D	ø 50
Key no. 3: Nominal diameter diaphragm (DN)				E	ø 63
8	25	50	100	F	ø 80
15	32	65		G	ø 100
20	40	80		H	ø 125
Key no. 4: Diaphragm material (DWST)				K	ø 175
AD	EPDM			L	ø 225
EA	PTFE/EPDM			M	ø 70
EU	Advanced PTFE/EPDM laminated			N	ø 90
ER	Gylon®/EPDM laminated			P	ø 130
Key no. 5: Body material (WKST)				Key no. 9: Pilot air port (ELEMENT) (STLA)	
PD	PVDF (Polyvinylidene fluoride)			FA01	Pilot air port Push-In 6/4, ¼"
PP	PP (Polypropylene)			FA02	Pilot air port G½
PV	PVC-U (Polyvinyl chloride)			FA03	Interface ELEMENT control
VG	Stainless steel precision casting 1.4435/316L			Key no. 10: Actuator (ANTR)	
VH	Stainless steel block material 1.4435/316L			D050	Handwheel and attachment PPS
VI	Stainless steel block material 1.4435 BN2/316L ASME BPE			D051 ^{1.)}	Handwheel PPS and attachment St. St.
VP	Stainless steel tube 1.4435 BN2/316L			D052 ^{2.)}	Handwheel and attachment St. St.
VS	Stainless steel-forged 1.4435 BN2/316L ASME BPE			1.) Alternatively D058	
Key no. 6: Port connection (LTA1, LTA2)				2.) Alternatively D059 or D102	
Listed in detail below				Key no. V1, V2, ...: Variable code (VAR1, VAR2, VAR3)	
Key no. 7: Actuator version (ANTA)				NK52 ^{3.)}	Acceptance test certificate 3.1 according to EN 10204
C	PA actuator (only CLASSIC)			NO14 ^{3.)}	Mechanically polished Ra ≤ 0.5 µm (ASME BPE SF1)
D	PPS actuator (only CLASSIC)			NO17 ^{3.)}	Electropolished Ra ≤ 0.38 µm (ASME BPE SF4 / DIN HE4)
G	ELEMENT design actuator (only ELEMENT)			NO06 ^{3.)}	Mechanically polished Ra ≤ 0.76 µm (ASME BPE SF3 / DIN H2)
H	St. St. actuator (only INOX)			NO16 ^{3.)}	Electropolished Ra ≤ 0.6 µm (ASME BPE SF6)
				EC04	Reduced spring force
				3.) NK52, NOxx only for stainless steel bodies	

Key no. 6: Port connection (LTA)

Weld connection								
DN [mm]	EN ISO 1127 / ISO 4200 DIN 11866 R. B	SMS 3008	DIN 11850 R. 0	DIN 11850 R. 1	DIN 11850 R. 2 DIN 11866 R. A	DIN 11850 R. 3	BS4825	ASME BPE DIN 11866 R. C
4	-	-	SC40-6.0x1.0	-	-	-	-	-
6	SA78-10.2x1.6	-	SC41-8.0x1.0	-	-	-	-	SA89-3.17x0.56
8	SA40-13.5x1.6	-	SC42-10.0x1.0	-	-	-	SODB-6.35x1.2	SA90-6.35x0.89
10	SA41-17.2x1.6	-	-	SF40-12.0x1.0	SD40-13.0x1.5	SE40-14.0x2.0	SODC-9.53x1.2	SA91-9.53x0.89
15	SA42-21.3x1.6	SA58-12.0x1.0	SC43-18.0x1.5	SF41-18.0x1.0	SD42-19.0x1.5	SE42-20.0x2.0	SODD-12.7x1.2	SA92-12.7x1.65
20	SA43-26.9x1.6	SA59-18.0x1.0	SC44-22.0x1.5	SF42-22.0x1.0	SD43-23.0x1.5	SE43-24.0x2.0	SODE-19.05x1.2	SA93-19.05x1.65
25	SA44-33.7x2.0	SA60-25.0x1.2	SC45-28.0x1.5	SF43-28.0x1.0	SD44-29.0x1.5	SE44-30.0x2.0	-	SODF-25.4x1.65
32	SA45-42.4x2.0	SA61-33.7x1.2	SC46-34.0x1.5	SF44-34.0x1.0	SD45-35.0x1.5	SE45-36.0x2.0	-	-
40	SA46-48.3x2.0	SA62-38.0x1.2	SC47-40.0x1.5	SF45-40.0x1.0	SD46-41.0x1.5	SE46-42.0x2.0	-	SODH-38.1x1.65
50	SA47-60.3x2.0	SA63-51.0x1.2	SC48-52.0x1.5	SF46-52.0x1.0	SD47-53.0x1.5	SE47-54.0x2.0	-	SODI-50.8x1.65
65	SA48-76.1x2.0	SA64-63.5x1.6	-	-	SD48-70.0x2.0	-	-	SODJ-63.5x1.65
80	SA49-88.9x2.3	SA65-76.1x1.6	-	-	SD49-85.0x2.0	-	-	SODK-76.2x1.65
100	SA39-114.3x2.3	SA66-101.6x2.0	-	-	SD50-104.0x2.0	-	-	SODL-101.6x2.11

Product Enquiry Form
Diaphragm valve with straight
way valve, T-valve or tank bottom
valve



Clamp connection					
DN [mm]	Clamp 34,0 similar to DIN 32676 R. B (ISO tube (ISO4200))	DIN 32676 R. A (DIN tube (DIN11850))	DIN 32676 R. B (ISO tube (ISO4200))	ASME BPE	BS 4825 (Clamp BS 4825-3, tube BS 4825-1)
8	TC51-13.5×1.6 Cl: 34.0	TD40-10.0×1.0 Cl: 25.0	TC40-13.5×1.6 Cl: 25.0	TG 50-6.35×0.89 Cl: 25.0	-
10	TC41-17.2×1.6 Cl: 34.0	TD41-13.0×1.5 Cl: 34.0	TC53-17.2×1.6 Cl: 25.0	TG 01-9.53×0.89 Cl: 25.0	-
15	TC42-21.3×1.6 Cl: 34.0	TD42-19,0×1.5 Cl: 34.0	TC52-21.3×1.6 Cl: 50.5	TG 02-12.7×1.65 Cl: 25.0	TH42-12.7×1.2 Cl: 25.0
20	-	TD43-23.0×1.5 Cl: 34.0	TC43-26.9×1.6 Cl: 50.5	TG 03-19.05×1.65 Cl: 25.0	TH43-19.05×1.2 Cl: 25.0
25	-	TD44-29.0×1.5 Cl: 50.5	TC44-33.7×2.0 Cl: 50.5	TG 04-25.4×1.65 Cl: 50.5	-
32	-	-	-	-	-
40	-	TD46-41.0×1.5 Cl: 50.5	TC46-48.3×2.0 Cl: 64.0	TG 05-38.1×1.65 Cl: 50.5	-
50	-	TD47-53.0×1.5 Cl: 64.0	TC47-60.3×2.0 Cl: 77.5	TG 06-50.8×1.65 Cl: 64.0	-
65	-	-	TC48-76.1×2.0 Cl: 91.0	TG 07-63.5×1.65 Cl: 77.5	-
80	-	-	TC49-88.9×2.3 Cl: 106.0	TG 08-76.2x,65 Cl: 91.0	-
100	-	-	TC50-114.3×2.3 Cl: 130.0	TG 09-101.6×2.11 Cl: 119.0	-

Plastic connection					
DN [mm]	Welded connection socket (only WKST=PD, PP)	Welded connection threaded socket (only WKST=PD, PP)	Adhesive bond socket (only WKST=PV)	Adhesive bond threaded socket (only WKST=PV)	Loose-type flange (up to DN65) Fixed flange (from DN80)
15	SS25 - ø20	SM25 - ø20	KS25 - ø20	KM25 - ø20	FL24
20	SS26 - ø25	SM26 - ø25	KS26 - ø25	KM26 - ø25	FL25
25	SS27 - ø32	SM27 - ø32	KS27 - ø32	KM27 - ø32	FL26
32	SS28 - ø40	SM28 - ø40	KS28 - ø40	KM28 - ø40	FL27
40	SS29 - ø50	SM29 - ø50	KS29 - ø50	KM29 - ø50	FL28
50	SS30 - ø63	SM30 - ø63	KS30 - ø63	KM30 - ø63	FL29
65	-	-	-	-	FL30
80	-	-	-	-	FF31
100	-	-	-	-	FF32

DTS 1000450621 EN Version: A Status: RL (released | freigegeben | validé) printed: 18.02.2021

