





Type 2060 Welded can be combined with...



**Type 8697**  
feedback

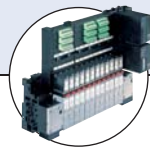

**Type 8640/8644**  
valve island



**Type 6012/6014 P**  
pilot valve



**Stroke limiter**



## Pneumatically operated 2/2-way angle seat valve with stainless steel actuator

- Flow optimized stainless steel bodies with various port connections
- Trusted inner parts for long cycle life
- Actuator in stainless steel for demanding environments
- Large accessory program with stroke limitation and feedback

The pneumatically operated angle seat valve with stainless steel actuators fulfils the demands of tough process environments. Unrivalled cycle life and sealing integrity is guaranteed by the trusted self-adjusting spindle packing with V-seals.

The stainless steel actuator is designed to withstand tough conditions. Laser welding allows a design without seals and smooth surfaces that is both cleanable and robust. With a ducted exhaust air port the actuator can be isolated from the environment an optimum from a lifetime and hygienic point of view.

High flow rates are attained with the optimized cast stainless steel 2 way body. Placed within the Bürkert process valves various port connections and a large accessory program are available.

All wetted parts comply with the EC-Regulation 1935/2004, variants with FDA conformity are available on request, also explosion proof variants are available.

Technical data	
<b>Orifice</b>	DN15 to DN65; 1/2" to 2 1/2"
<b>Port connections</b> <b>Welded acc. to</b>	DIN EN ISO 1127/ISO 4200/DIN 11866 series B DIN 11850 series 2/DIN 11866 series A/DIN EN 10357 series A ASME BPE / DIN 11866 series C on request: SMS 3008 and BS485
<b>Clamp and threaded</b>	on request
<b>Body material</b>	Stainless steel 316L
<b>Nominal pressure</b>	PN25 (Body)
<b>Actuator material</b>	1.4404 (316L), 1.4308
<b>Sealing material</b>	PTFE (others on request)
<b>Medium</b>	Water, alcohol, oils, fuels, hydraulic fluids, salt solution, alkali solutions, organic solvents, steam
<b>Viscosity</b>	max. 600 mm <sup>2</sup> /s
<b>Spindle packing</b>	PTFE V-rings with spring compensation
<b>Medium temperature</b>	-10°C to 185°C
<b>Ambient temperature</b>	0°C to 100°C at 150°C ambient temperature 0°C to 80°C at 150°C < ambient temperature ≤ 185°C
<b>Control medium</b>	Neutral gases, air
<b>Max. pilot pressure</b>	10.5 bar 7.5 bar for actuator size 130mm (P)
<b>Pilot air ports</b>	thread G1/8
<b>Installation</b>	As required, preferably with actuator in upright position
<b>Surface Finish</b>	Int. Ra ≤ 3,2µm (others on request)

### Content

 Valve specifications		 System spec. On/Off ELEMENT		 Request for quotation
<b>Type 2060</b>		<b>Type 8801-YE</b>		<b>Type 8801-YE</b>
Technical data & ordering info.	p. 1-4	Technical data & ordering info.	p. 9	p. 11

Technical data angle seat valve Type 2060 flow direction below the seat (for gases and liquids)

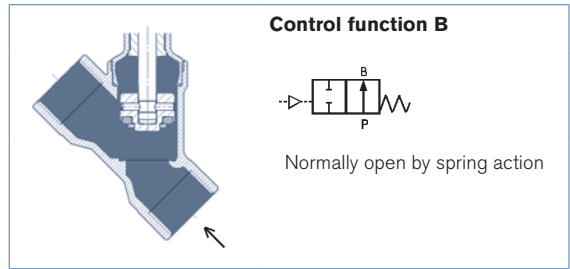
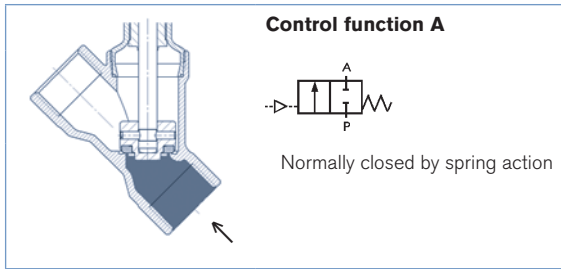

Orifice [mm]	Orifice [inch]	Actuator size [mm]	Kv value water [m <sup>3</sup> /h]	Minimum pilot pressure CFA [bar]	Operating pressure up to +185°C	
					CFA [bar]	CFB [bar]
15	1/2"	50 (D)	4.2	4.0	16	16
20	3/4"	50 (D)	8	4.0	16	16
		70 (M)	11	5.0	16	16
25	1"	50 (D)	14	4.0	9	16
		70 (M)	18	5.0	16	16
32	1 1/4"	70 (M)	27	5.0	8.5	16
		90 (N)	28	5.0	16	16
40	1 1/2"	70 (M)	38	5.0	6	16
		90 (N)	40	5.0	16	16
50	2"	90 (N)	55	5.0	10	16
		130 (P)	62	5.0	16	16
65	2 1/2"	90 (N)	85	5.0	5	12
		130 (P)	95	5.6	12	12

**Flow rate:** Kv value water [m<sup>3</sup>/h]: Measured at +20°C, 1 bar pressure at valve inlet and free outlet.

**Pressure valves [bar]:** Overpressure to the atmospheric pressure

Pressure charts with control function B and flow direction below the seat

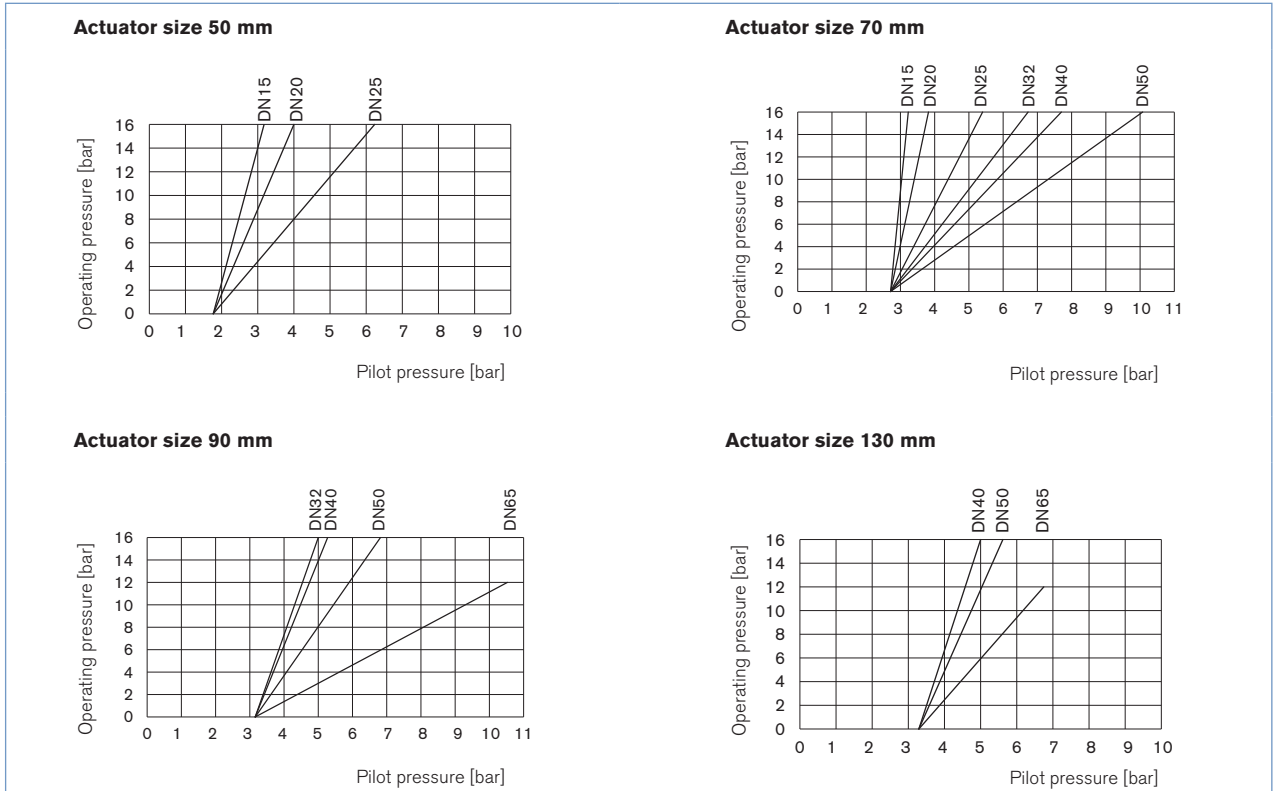

## Ordering chart angle seat valve Type 2060, flow direction below the seat (for gases and liquids)

Weld end body, flow direction below the seat, others on request

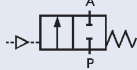
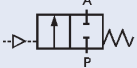
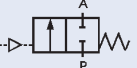
Control function	Orifice		Port connection tube Ø x wall thickness [mm]	Actuator size [mm]	Pilot pressure [bar]	Operating pressure up to +185°C [bar]	Item no.
	[mm]	[inch]					
<b>Acc. EN ISO 1127/ISO 4200/DIN 11866 series B</b>							
<b>A</b> 2/2-way valve, externally controlled, normally closed by spring operation with pilot valve (NC) 	15	1/2"	21.3 x 1.6	50 (D)	4.0 - 10.5	16	285 215
	20	3/4"	26.9 x 1.6	50 (D)	4.0 - 10.5	16	285 217
				70 (M)	5.0 - 10.5	16	285 218
	25	1"	33.7 x 2.0	50 (D)	4.0 - 10.5	9	285 219
				70 (M)	5.0 - 10.5	16	285 220
	32	1 1/4"	42.4 x 2.0	70 (M)	5.0 - 10.5	8.5	285 221
				90 (N)	5.0 - 10.5	16	285 222
	40	1 1/2"	48.3 x 2.0	70 (M)	5.0 - 10.5	6	285 223
				90 (N)	5.0 - 10.5	16	285 224
	50	2"	60.3 x 2.0	90 (N)	5.0 - 10.5	10	285 515
			130 (P)	5.0 - 7.5	16	285 705	
65	2 1/2"	76.1 x 2.3	90 (N)	5.0 - 10.5	5	285 227	
			130 (P)	5.6 - 7.5	12	285 228	
<b>Acc. DIN 11850 series 2/DIN 11866 series A/DIN EN 10357 series A</b>							
<b>A</b> 2/2-way valve, externally controlled, normally closed by spring operation with pilot valve (NC) 	15	1/2"	19.0 x 1.5	50 (D)	4.0 - 10.5	16	285 201
	20	3/4"	23.0 x 1.5	50 (D)	4.0 - 10.5	16	285 203
				70 (M)	5.0 - 10.5	16	285 204
	25	1"	29.0 x 1.5	50 (D)	4.0 - 10.5	9	285 205
				70 (M)	5.0 - 10.5	16	285 206
	32	1 1/4"	35.0 x 1.5	70 (M)	5.0 - 10.5	8.5	285 207
				90 (N)	5.0 - 10.5	16	285 208
	40	1 1/2"	41.0 x 1.5	70 (M)	5.0 - 10.5	6	285 209
				90 (N)	5.0 - 10.5	16	285 210
	50	2"	53.0 x 1.5	90 (N)	5.0 - 10.5	10	285 211
			130 (P)	5.0 - 7.5	16	285 212	
65	2 1/2"	70.0 x 2.0	90 (N)	5.0 - 10.5	5	285 213	
			130 (P)	5.6 - 7.5	12	285 214	
<b>Acc. ASME BPE/DIN 11866 series C</b>							
<b>A</b> 2/2-way valve, externally controlled, normally closed by spring operation with pilot valve (NC) 	15	1/2"	12.7 x 1.65	50 (D)	4.0 - 10.5	16	285 189
	20	3/4"	19.05 x 1.65	50 (D)	4.0 - 10.5	16	285 191
				70 (M)	5.0 - 10.5	16	285 192
	25	1"	25.4 x 1.65	50 (D)	4.0 - 10.5	9	285 193
				70 (M)	5.0 - 10.5	16	285 194
	40	1 1/2"	38.1 x 1.65	70 (M)	5.0 - 10.5	6	285 195
				90 (N)	5.0 - 10.5	16	285 196
	50	2"	50.8 x 1.65	90 (N)	5.0 - 10.5	10	285 197
				130 (P)	5.0 - 7.5	16	285 198
	65	2 1/2"	63.5 x 1.65	90 (N)	5.0 - 10.5	5	285 199
			130 (P)	5.6 - 7.5	12	285 200	

 Further versions on request

 **Control function**  
I (double-acting)

 **Port connection**  
(threaded port / clamp)

## Ordering chart angle seat valve Type 2060, flow direction below the seat (for gases and liquids)

Weld end body, flow direction below the seat, others on request

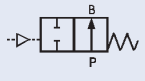
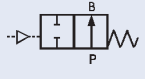
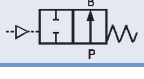
Control function	Orifice		Port connection tube Ø x wall thickness [mm]	Actuator size [mm]	Pilot pressure [bar]	Operating pressure up to +185°C [bar]	Item no.
	[mm]	[inch]					
<b>Acc. EN ISO 1127/ISO 4200/DIN 11866 series B</b>							
<b>B</b> 2/2-way valve, externally controlled, normally opened by spring, operation with pilot valve (NO) 	15	1/2"	21.3 x 1.6	50 (D)	see pressure chart	16	285 500
				70 (M)		16	287 565
	20	3/4"	26.9 x 1.6	50 (D)		16	285 501
				70 (M)		16	287 566
	25	1"	33.7 x 2.0	70 (M)		16	285 503
				70 (M)		16	285 504
	40	1 1/2"	48.3 x 2.0	70 (M)		16	285 505
70 (M)				16	287 567		
65	2 1/2"	76.1 x 2.3	90 (N)	12	285 511		
<b>Acc. DIN 11850 series 2/DIN 11866 series A/DIN EN 10357 series A</b>							
<b>B</b> 2/2-way valve, externally controlled, normally opened by spring, operation with pilot valve (NO) 	15	1/2"	19.0 x 1.5	50 (D)	see pressure chart	16	287 555
				70 (M)		16	287 556
	20	3/4"	23.0 x 1.5	50 (D)		16	287 557
				70 (M)		16	287 558
	25	1"	29.0 x 1.5	70 (M)		16	287 559
				70 (M)		16	287 560
	32	1 1/4"	35.0 x 1.5	70 (M)		16	287 561
70 (M)				16	287 562		
65	2 1/2"	70.0 x 2.0	90 (N)	12	287 563		
<b>Acc. ASME BPE/DIN 11866 series C</b>							
<b>B</b> 2/2-way valve, externally controlled, normally opened by spring, operation with pilot valve (NO) 	15	1/2"	12.7 x 1.65	50 (D)	see pressure chart	16	285 499
				70 (M)		16	287 548
	20	3/4"	19.05 x 1.65	50 (D)		16	287 549
				70 (M)		16	287 550
	25	1"	25.4 x 1.65	70 (M)		16	287 551
				70 (M)		16	287 552
	40	1 1/2"	38.1 x 1.65	70 (M)		16	285 509
70 (M)				16	287 553		
65	2 1/2"	63.5 x 1.65	90 (N)	12	287 553		

**Technical data angle seat valve Type 2060 flow direction above the seat** (for gases and liquids)

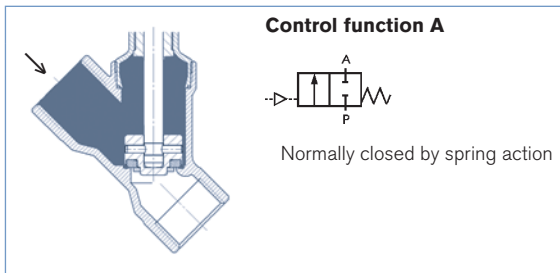

**Attention!**

Valves with flow above the seat are only conditionally usable for liquid medium. There is a danger of waterhammer!

Orifice	Actuator size		Kv value water [m³/h]	Operating pressure up to +185°C CFA [bar]
	[mm]	[inch]		
15	1/2"	50 (D)	4.2	16
20	3/4"	50 (D)	8	16
25	1"	50 (D)	14	16
32	1 1/4"	70 (M)	28	16
40	1 1/2"	70 (M)	38	16
50	2"	70 (M)	50	12
		90 (N)	55	15

**Flow rate:** Kv value water [m³/h]: Measured at +20°C, 1 bar pressure at valve inlet and free outlet.

**Pressure valves [bar]:** Overpressure to the atmospheric pressure

**Pressure charts with control function A and flow direction above the seat**

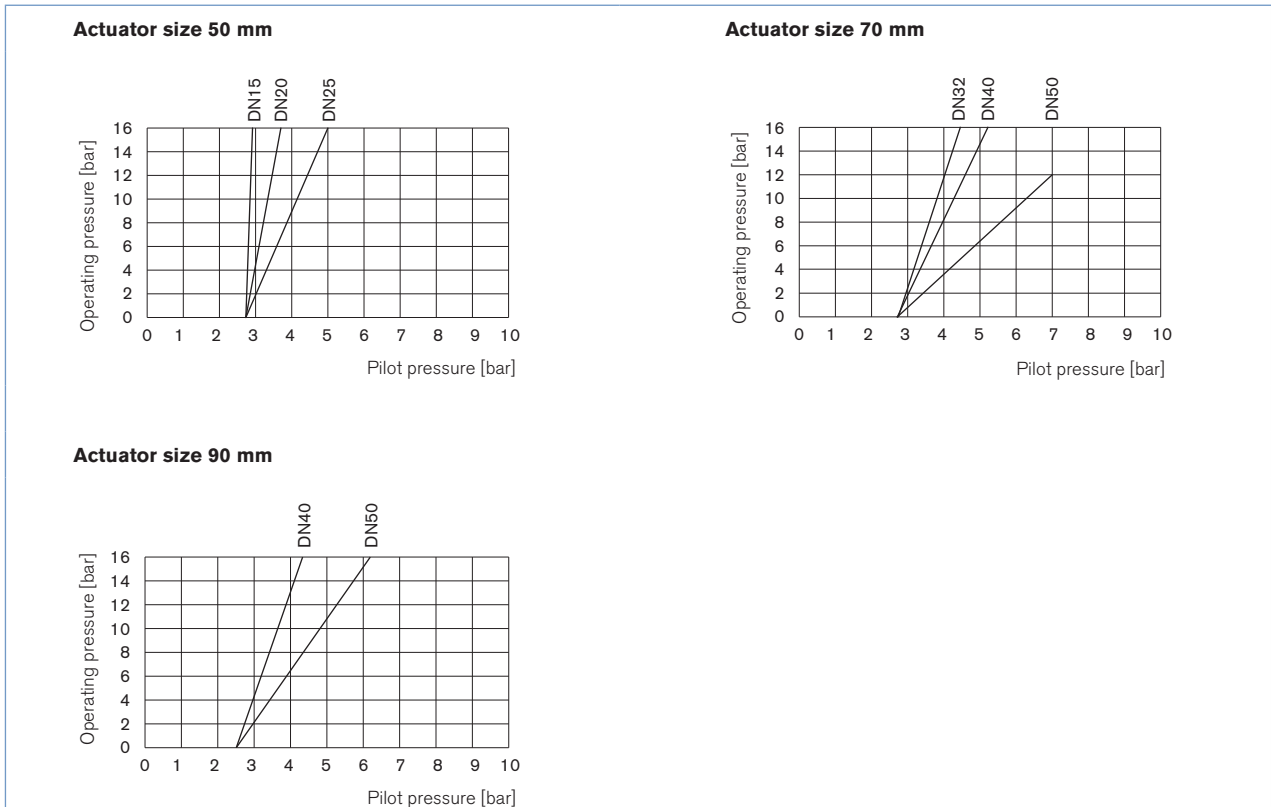

## Ordering chart angle seat valve Type 2060, flow direction above the seat (for gases and liquids)

Weld end body, flow direction above the seat, others on request

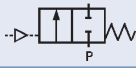
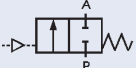
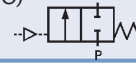
Control function	Orifice		Port connection tube $\varnothing$ x wall thickness [mm]	Actuator size [mm]	Pilot pressure [bar]	Operating pressure up to +185°C [bar]	Item no.
	[mm]	[inch]					
<b>Acc. EN ISO 1127/ISO 4200/DIN 11866 series B</b>							
<b>A</b> 2/2-way valve, externally controlled, normally closed by spring operation with pilot valve (NC) 	15	1/2"	21.3 x 1.6	50 (D)	see pressure chart	16	287 541
	20	3/4"	26.9 x 1.6	50 (D)		16	287 542
	25	1"	33.7 x 2.0	50 (D)		16	287 543
	32	1 1/4"	42.4 x 2.0	70 (M)		16	287 544
	40	1 1/2"	48.3 x 2.0	70 (M)		16	287 545
	50	2"	60.3 x 2.0	70 (M)		12	287 546
				90 (N)	16	287 547	
<b>Acc. DIN 11850 series 2/DIN 11866 series A/DIN EN 10357 series A</b>							
<b>A</b> 2/2-way valve, externally controlled, normally closed by spring operation with pilot valve (NC) 	15	1/2"	19.0 x 1.5	50 (D)	see pressure chart	16	287 534
	20	3/4"	23.0 x 1.5	50 (D)		16	287 535
	25	1"	29.0 x 1.5	50 (D)		16	287 536
	32	1 1/4"	35.0 x 1.5	70 (M)		16	287 537
	40	1 1/2"	41.0 x 1.5	70 (M)		16	287 538
	50	2"	53.0 x 1.5	70 (M)		12	287 539
				90 (N)	16	287 540	
<b>Acc. ASME BPE/DIN 11866 series C</b>							
<b>A</b> 2/2-way valve, externally controlled, normally closed by spring operation with pilot valve (NC) 	15	1/2"	12.7 x 1.65	50 (D)	see pressure chart	16	287 528
	20	3/4"	19.05 x 1.65	50 (D)		16	287 529
	25	1"	25.4 x 1.65	50 (D)		16	287 530
	40	1 1/2"	38.1 x 1.65	70 (M)		16	287 531
	50	2"	50.8 x 1.65	70 (M)		12	287 532
						90 (N)	16

## Materials angle seat valve Type 2060

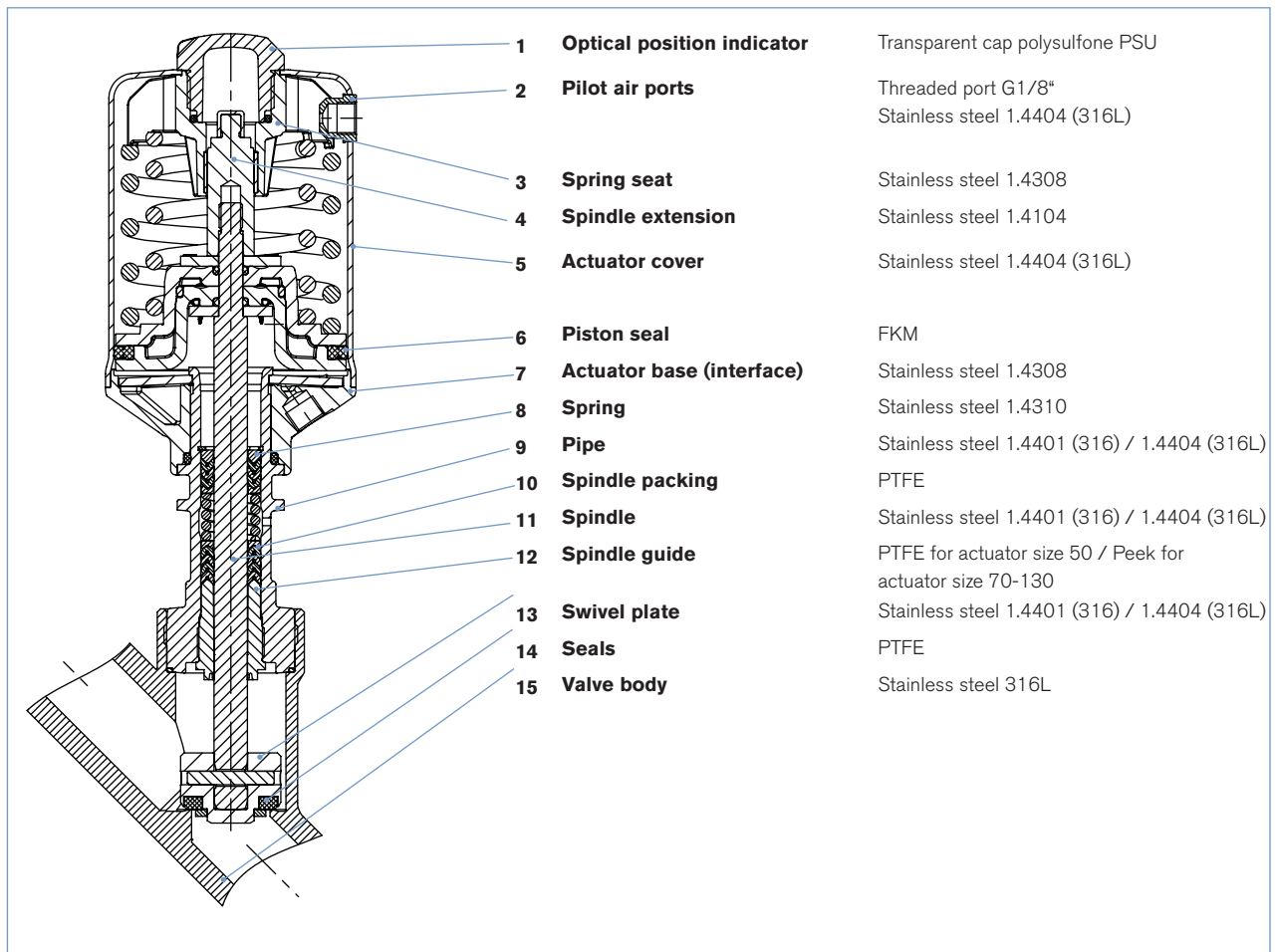



Dimensions angle seat valve Type 2060 [mm]

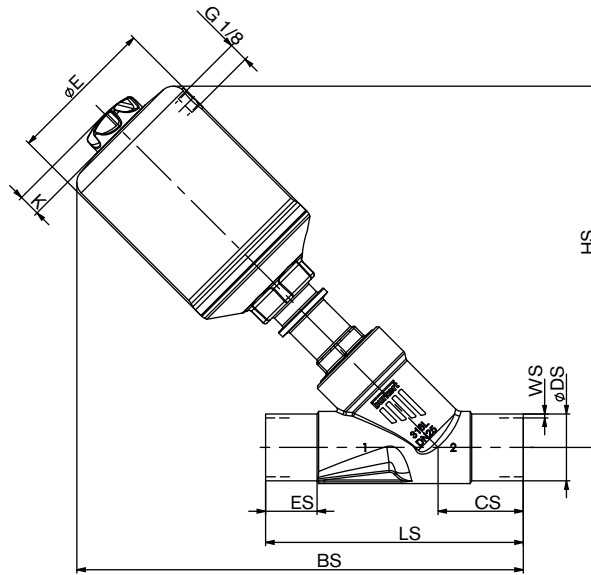

Acc. EN ISO 1127/ISO 4200/DIN 11866 series B, acc. ASME BPE/DIN 11866 series C, acc. DIN 11850 series 2/DIN 11866 series A/DIN EN 10357 series A

All bodies					acc. EN ISO 1127/ISO 4200/DIN 11866 series B						acc. ASME BPE/DIN 11866 series C					
DN [mm]	Actuator size [mm]	ØE [mm]	K [mm]	HS [mm]	BS [mm]	CS [mm]	LS [mm]	ØDS [mm]	ES [mm]	WS [mm]	BS [mm]	CS [mm]	LS [mm]	ØDS [mm]	ES [mm]	WS [mm]
15	50 (D)	55	26.5	150	184	34	100	21.3	19	1.6	293	45	135	19	15	1.65
	70 (M)	75	26.5	171	209						220					
20	50 (D)	55	26.5	155	194	39	115	26.9	20	1.6	197	52	145	19.05	25	1.65
	70 (M)	75	26.5	178	217						234					
25	50 (D)	55	26.5	161	204	43	130	33.7	26	2	212	51	152	25.4	30	1.65
	70 (M)	75	26.5	183	226						234					
32	70 (M)	75	26.5	191	236	45	145	42.4	26	2	n/a	n/a	n/a	n/a	n/a	n/a
	90 (N)	96	29	236	281						n/a					
40	70 (M)	75	26.5	197	246	49	160	48.3	26	2	257	60	182	38.1	30	1.65
	90 (N)	96	29	242	291						302					
50	70 (M)	75	26.5	214	264	50	175	60.3	26	2.6	278	64	210	50.8	30	1.65
	90 (N)	96	29	257	307						321					
	130 (P)	137	29	301	352						352					
65	90 (N)	96	29	269	319	50	210	76.1	26	2.3	307	56	230	63.5	26	1.65
	130 (P)	137	29	314	364						370					

All bodies					acc. DIN 11850 series 2/DIN 11866 series A/DIN EN 10357 series A					
DN [mm]	Actuator size [mm]	ØE [mm]	K [mm]	HS [mm]	BS [mm]	CS [mm]	LS [mm]	ØDS [mm]	ES [mm]	WS [mm]
15	50 (D)	55	26.5	150	184	34	100	19	20	1.5
	70 (M)	75	26.5	171	209					
20	50 (D)	55	26.5	155	194	39	115	23	20	1.5
	70 (M)	75	26.5	178	217					
25	50 (D)	55	26.5	161	204	43	130	29	26	1.5
	70 (M)	75	26.5	183	226					
32	70 (M)	75	26.5	191	236	45	145	35	26	1.5
	90 (N)	96	29	236	281					
40	70 (M)	75	26.5	197	246	49	160	41	26	1.5
	90 (N)	96	29	242	291					
50	70 (M)	75	26.5	214	264	50	175	53	26	1.5
	90 (N)	96	29	257	307					
	130 (P)	137	29	301	352					
65	90 (N)	96	29	269	319	50	210	70	26	2
	130 (P)	137	29	314	364					

## Ordering information for valve system On/Off Type 8801-YV

A **valve system On/Off Type 8801-YV** consists of a **angle seat valve Type 2060** and feedback **Type 8697** (see separate datasheets). For the configuration of further valve systems Type 2060 and a feedback **Type 8697** (see separate datasheets) please use the "Request for quotation" on p. 11-12. [go to page](#)

### Angle seat valve Type 2060 Welded



### Feedback Type 8697



### Valve System On/Off ELEMENT



**Type 8801-YV  
2060 + 8697**

### Electrical position feedback

More  
info.



### Type 8697

Actuator size 40 to 225

The pneumatic control unit Type 8697 is designed for integrated mounting on CLASSIC series 20XX process valves suiting the requirements of hygienic process environment Mechanical or inductive limit switches register the position of the valve.

### Features

- Compact design
- LED position indicator
- Mechanical or inductive limit switches for end position registering
- Easy to clean chemically resistant housing featuring IP65 / IP67, 4X Rating
- Optional intrinsically safe version acc. to ATEX

### Benefits

- Easy and quick installation
- High level of signal reliability thanks to self adjusting limit switches
- Signal safety through the automatic adjustment of the limit switches
- Minimised space requirement in the plant piping for more flexibility in plant design

### Dimensions for valve system On/Off with stainless steel actuator Type 8801-YV [mm]

Dimensions valve system On/Off ELEMENT Type 8801-YE-K (with pneumatic control unit Type 8690)

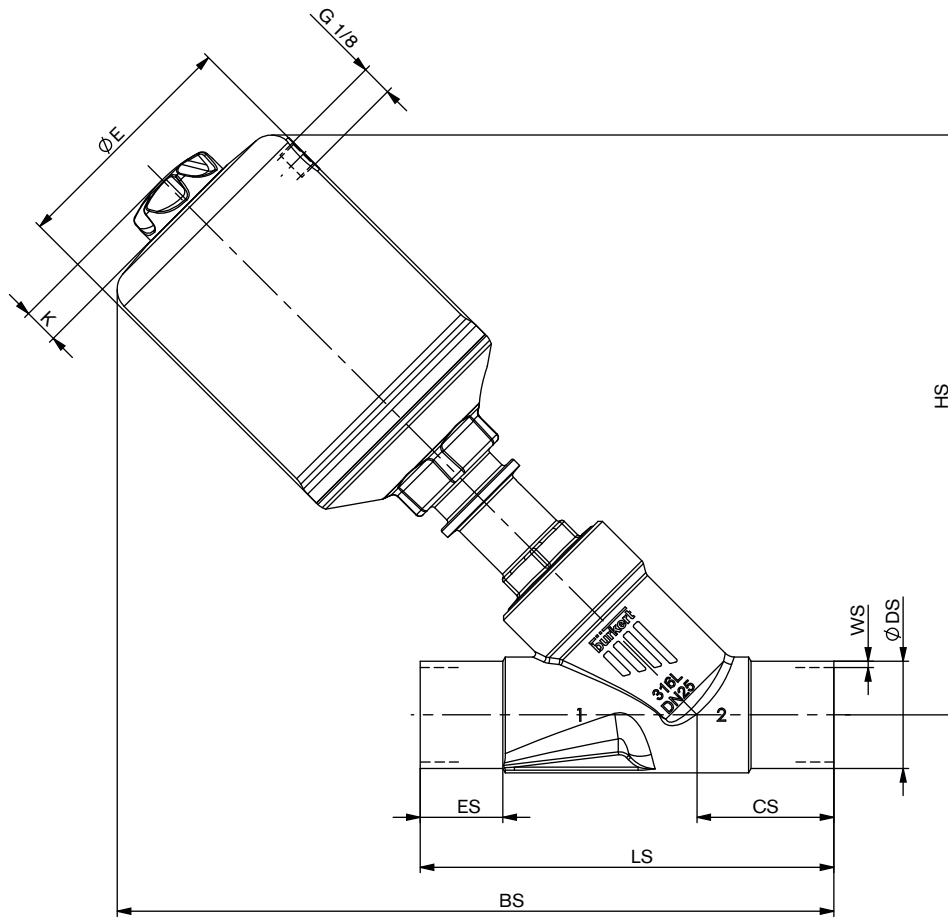

Orifice [mm]	Actuator size [mm]	BM	HM
15	D	262.5	229.1
	M	277.4	244
20	D	272.4	234.1
	M	290	251.6
25	D	282.8	240.4
	M	298.4	256.1
32	M	308.9	264.6
	N	355.9	307.5
40	M	318.4	270.1
	N	342.7	298.4
50	M	337.3	287.9
	N	368.2	318.9
	P	399.6	350.3
65	N	385.9	331.6
	P	412.4	363

Further dimensions see p. 8

**Ordering chart for accessories**

Accessories has to be ordered separately

Accessory	for actuator size	Item no.
Stainless steel Silencer Set (VA-Silencer incl. PTFE sealing ring)	universal	696 931
Max. stroke limitation	D (Ø50), M (Ø70)	699 550
	N (Ø90), P (Ø130)	699 994
Min.-/Max. stroke limitation	D (Ø50), M (Ø70)	699 986
	N (Ø90), P (Ø130)	699 998
Proximity switch (single)	D (Ø50), M (Ø70)	699 989
	N (Ø90), P (Ø130)	699 991
Proximity switch (double)	D (Ø50), M (Ø70)	699 990
	N (Ø90), P (Ø130)	699 992
Adaptionsset 8697*	D (Ø50), M (Ø70)	699 551
	N (Ø90), P (Ø130)	580 000
8697*	universal	depending on version

For further accessories see accessories datasheet Type 2XXX for the full options programme.

More info.

**Note**

You can fill out the fields directly in the PDF file before printing out the form.

**Valve system On/Off ELEMENT Type 8801-YE – request for quotation**

▶ Please fill out and send to your nearest Bürkert facility\* with your inquiry or order

Company	Contact person
Customer no.	Department
Address	Tel./Fax
Postcode/town	E-Mail

= mandatory fields to fill out

Quantity

Required delivery date

**Operating data**

Pipe line DN  PN

Pipe material

Process medium

Type of media  Liquid  Steam  Gas

**Valve features**

Seal material  PTFE  NBR  Other

Nominal pressure PN

Orifice DN

Type of connection  Threaded  Welded  Clamp

Standard connection  ISO  DIN  Other

Control function  NC <sup>1)</sup>  NO <sup>1)</sup>  Double-acting

Pilot pressure  min.  max.

Atex II 2GD Mechanical

Please specify item no. (if known):

<sup>1)</sup> NC: normally closed by spring action; NO: normally open by spring action

Continued on next page →

**Valve system On/Off ELEMENT Type 8801-YE – request for quotation, *continued***

**Automation unit features**

Click on the orange box "More info"... you will come to our website for the resp. product where you can download the data sheet.

**Electrical Feedback**

**Type 8697**  
For actuator size 50 to 130



- LED-position indicator
- Micro- or proximity switches for end position feedback
- Gehäuse nach IP 65/67, 4X Rating
- Optional intrinsically safe version acc. to ATEX / IECEx

**Position feedback switches**

- Micro-switch 24V DC
- Micro-switch 50 – 225 V DC/AC
- Inductive switch 3-wire PNP
- Inductive switch 2-wire NAMUR
- Inductive switch 2-wire 24V DC

**Electrical connection**

- Cable gland
- M12 plug  
(only with inductive switch 3-wire PNP)

**No. of Position feedback switches Approvals**

- 2x
- ATEX cat. 3GD, IECEx
- ATEX cat. 2DG, IECEx
- without

**Certifications**

- Attestation of compliance with the order EN-ISO 10204 2.1 (Item-No. 440 788)
- Test report EN-ISO 10204 2.2 (Item-No. 803 722)
- Certification of Conformity for Raw Material EN-ISO 10204 3.1 (Included in delivery)
- FDA compliance
- Compliance EC-Regulation 1935/2004

**Comment /sketch**

To find your nearest Bürkert facility, click on the orange box →

In case of special application conditions, please consult for advice.

Subject to alteration.  
© Christian Bürkert GmbH & Co. KG

1604/0\_EU-en\_00895312

