

По вопросам продаж и поддержки обращайтесь:

Архангельск (8182)63-90-72	Краснодар (861)203-40-90	Рязань (4912)46-61-64
Астана (7172)727-132	Красноярск (391)204-63-61	Самара (846)206-03-16
Белгород (4722)40-23-64	Курск (4712)77-13-04	Санкт-Петербург (812)309-46-40
Брянск (4832)59-03-52	Липецк (4742)52-20-81	Саратов (845)249-38-78
Владивосток (423)249-28-31	Магнитогорск (3519)55-03-13	Смоленск (4812)29-41-54
Волгоград (844)278-03-48	Москва (495)268-04-70	Сочи (862)225-72-31
Вологда (8172)26-41-59	Мурманск (8152)59-64-93	Ставрополь (8652)20-65-13
Воронеж (473)204-51-73	Набережные Челны (8552)20-53-41	Тверь (4822)63-31-35
Екатеринбург (343)384-55-89	Нижний Новгород (831)429-08-12	Томск (3822)98-41-53
Иваново (4932)77-34-06	Новокузнецк (3843)20-46-81	Тула (4872)74-02-29
Ижевск (3412)26-03-58	Новосибирск (383)227-86-73	Тюмень (3452)66-21-18
Казань (843)206-01-48	Орел (4862)44-53-42	Ульяновск (8422)24-23-59
Калининград (4012)72-03-81	Оренбург (3532)37-68-04	Уфа (347)229-48-12
Калуга (4842)92-23-67	Пенза (8412)22-31-16	Челябинск (351)202-03-61
Кемерово (3842)65-04-62	Пермь (342)205-81-47	Череповец (8202)49-02-64
Киров (8332)68-02-04	Ростов-на-Дону (863)308-18-15	Ярославль (4852)69-52-93

Единый адрес: btk@nt-rt.ru **Веб-сайт:** www.burkert.nt-rt.ru

**ПНЕВМАТИКА,
АВТОМАТИКА**



AirLINE - the valve island optimised for process automation

- Safety-related shut-off of valves possible
- Easy diagnostics via LC display
- Process reliability through pneumatic functions
- Optimised for installation at the bottom of the control cabinet
- Explosion-proof variants according to ATEX / IECEx Zone 2

Product variants described in the data sheet may differ from the product presentation and description.

Can be combined with



Type ME43
Fieldbus gateway



Type 2012 ▶
Pneumatically operated
2/2 way globe valve
CLASSIC



Type 8695
Control head for de-
centralised automation
of ELEMENT process
valves



Type 8920
Bürkert Communicator



Type 8653 ▶
AirLINE Field - the valve
island optimised for
process automation



Type 8614
Pneumatic control
cabinet solutions for
hygienic process envi-
ronments



Type SV04
Wear part sets pneu-
matic valves for Type
8652

Type description

The valve island Type 8652 AirLINE has been especially developed for process automation requirements. New diagnostic functions can be visualised on the LC display, both in clear text as well as symbols. This makes it easy to relate to the shown messages and helps to save time during start-up and maintenance. Furthermore, the diagnostic message is also available at the controller. This, therefore, enables a fast overview of the plant status. The hardware is optimised for installation at the bottom of the control cabinet. Installation on a standard rail is, of course, also possible. Moreover, key pneumatic functions ensure increased process reliability. For instance, check valves in the exhaust air ducts make sure there is no unplanned actuation due to pressure peaks.

1. General Technical Data

Product properties	
Materials	
Body	PA (Polyamide)
Seal	NBR and PUR
Width/station	11 mm
Pressure range	Vak. bis 10 bar
Max. number of modules	6
Number of valve positions per module	4 valve positions (max. 8 valve functions)
Max. number valve functions	48
Manual override	Latching, spring-return (optional: lockable)
Electrical data	
Operating voltage	24 V DC
Voltage tolerance	± 10 %
Nominal power per valve	0.7 W (0.175 W after power reduction)
Rated current per valve	29 mA (10 mA after power reduction)
Performance data	
Valve island	
Flow rate	310 l/min ¹⁾
Pilot valve Type 6534	
Flow rate: Q _{Nn} value air	Measured at +20 °C, 6 bar pressure at valve inlet and 1 bar pressure difference
Switching times	Measured according to ISO 12238
Medium data	
Medium	Compressed air, lubricated, oil free, dry; neutral gases (5 µm filter recommended)
Compressed air quality	ISO 8573-1:2010, Class 7.4.4
Product connections	
Valve island	
Working port	Connector diameter 6 mm, D ¼"
Air supply port	Connector diameter 10 mm, D ⅜"
Communication interface	
Communication	PROFIBUS DP Industrial Ethernet (PROFINET I/O, EtherNet IP, Modbus TCP, EtherCAT) CC-Link CANopen bùS ²⁾ (for networking with Bürkert devices)
Communication module	Type ME43 ▶
Approvals and Certificates	
Approvals	ATEX, Zone 2 (BVS 20 ATEX E 031 U) IECEX, Zone 2 (IECEX BVS 20.0024 U)
Degree of protection	IP20, IP65 in closed field housing
Environment and installation	
Ambient temperature	-10...+55 °C
Storage temperature	-10...+60 °C
Installation position	Any

1.) Maximum flow rate depending on valve function – see table "2. Circuit functions" on page 4.

2.) The Bürkert Communicator software ▶ and the corresponding USB-bùS Interface Set 1 with Article no. 772426 are required for commissioning.

2. Circuit functions

Control function	Description
	Type: C, solenoid valve 2 x 3/2 way Servo-controlled, with manual override Normally closed
	Type: C, solenoid valve 2 x 3/2 way (SIA variant) Servo-controlled Normally closed
	Type: D, solenoid valve 2 x 3/2 way Servo-controlled, with manual override Normally open
	Type: H, solenoid valve 5/2 way Servo-controlled, with manual override, with auxiliary pilot air Normally open
	Type: H, solenoid valve 5/2 way (SIA variant) Servo-controlled Normally open
	Type: L, solenoid valve 5/3 way Centre position all connections locked, with manual override Normally closed
	Type: L, solenoid valve 5/3 way (SIA variant) Centre position all connections locked Normally closed
	Type: Z, solenoid valve 5/2 way Impulse version with 2 coils, with manual override Normally open

3. Dimensions

3.1. Version 4-, 8- and 12-fold

Note:

Dimensions in mm

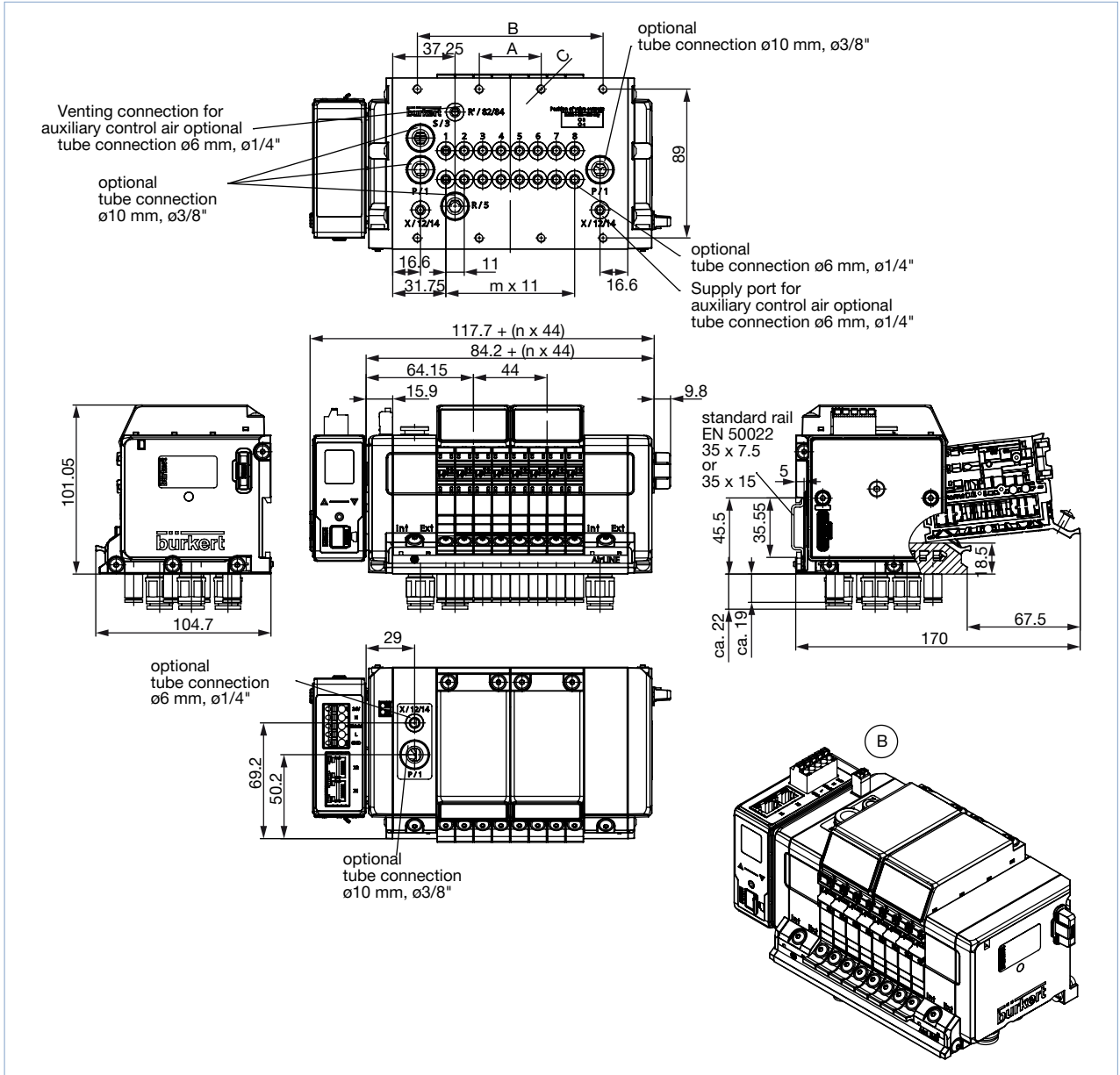

Version	A	B	C	m	n
4-fold	66	-	4 x M5	3	1
8-fold	37	111	8 x M5	7	2
12-fold	77	154	10 x M5	11	3

DTS 1000336890 EN Version: N Status: RL (released | freigegeben | valide) printed: 28.09.2020

3.2. Version 16-, 20- and 24-fold

Note:

Dimensions in mm

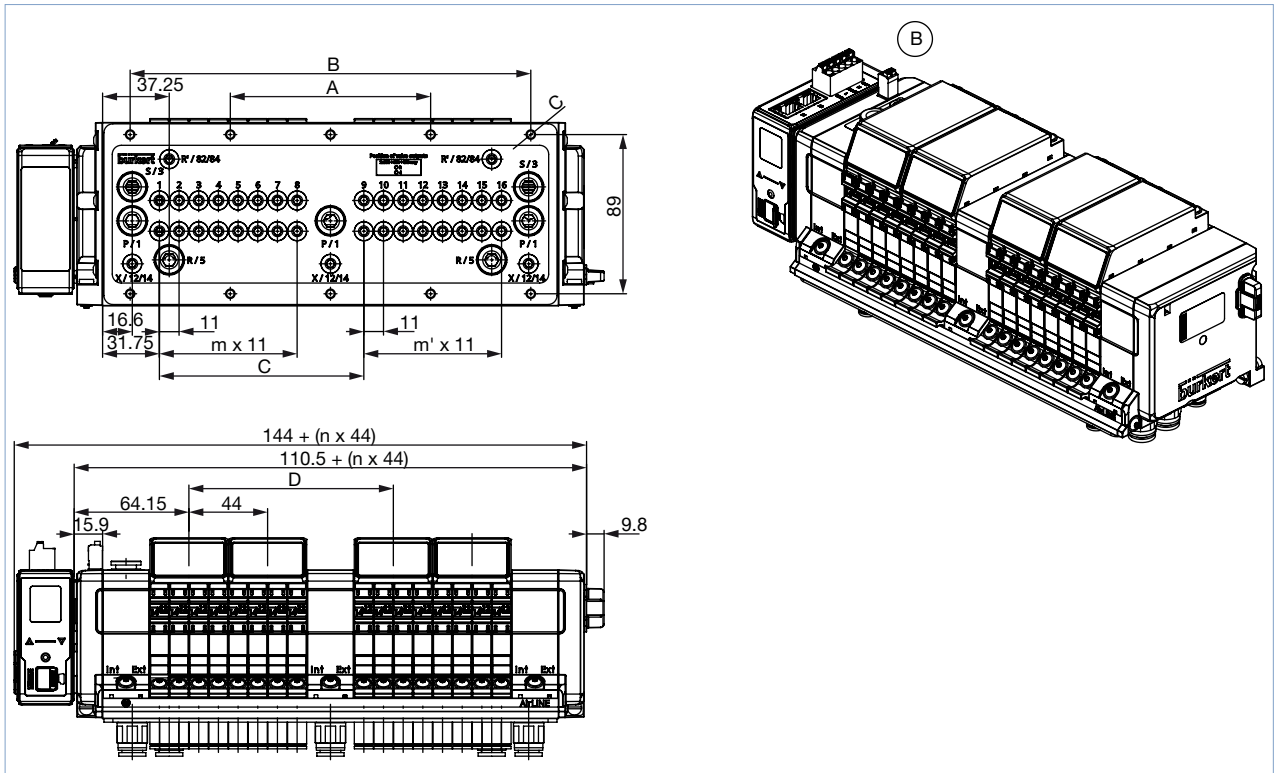

Version	A	B	C	D	m	m'	n
16-fold	112	224	10 x M5	114.3	7	7	4
20-fold	134	268	10 x M5	158.3	11	7	5
24-fold	156	312	10 x M5	158.3	11	11	6

4. Device/Process connections

4.1. Power supply for communication and display

Note:

- Connect the 5 pin spring-loaded terminal according to the assignment.
- Possible cable cross-section: $\leq 1.5 \text{ mm}^2$

Spring-loaded terminal 5 pin	Color	Assignment
	Red	24 V DC
	White	CAN H (bùS connection)
	Green	SHIELD
	Blue	CAN L (bùS connection)
	Black	GND

4.2. Power supply for pneumatic valves

Note:

The interface plate has a 2 pin spring-loaded terminal to which the supply voltage of the pneumatic valves is connected.

Spring-loaded terminal 2 pin	Clip	Assignment
	1, Red	AUX 24 V
	2, Black	GND

4.3. Fieldbus interface

Note:

CANopen requires two termination resistors: one at the beginning and one at the end of the network. An indicator of the correct bus termination is the resistance between CAN_H and CAN_L when the power supply is disconnected; this should be about 60 Ohm.

CANopen / bÜS - Spring terminal 5 pin	Color	Assignment
	Red	24 V DC
	White	CAN H (bÜS connection)
	Green	SHIELD
	Blue	CAN L (bÜS connection)
	Black	GND

Industrial Ethernet RJ45 - Interface X1 and X2	Pin	Assignment
	1	TX+
	2	TX-
	3	RX+
	4	N.C.
	5	N.C.
	6	RX-
	7	N.C.
	8	N.C.

PROFIBUS-DPV1 D-Sub 9 - D-Sub 9 pin female	Pin	Assignment
	1	SHIELD
	2	M24 (optional)
	3	RxD/TxD-P (B-Line)
	4	CNTR-P (optional)
	5	DGND
	6	+5 V (Supply for the termination resistor)
	7	+24 V (optional)
	8	RxD/TxD-N (A-Line)
	9	CNTR-N (optional)

CC Link D-Sub 9 pin female	Pin	Assignment
	1	N.C.
	2	N.C.
	3	DA data cable - (A-Line)
	4	DG data ground
	5	N.C.
	6	N.C.
	7	N.C.
	8	DB data cable + (B-Line)
	9	N.C.

DTS 1000336890 EN Version: N Status: RL (released | freigegeben | validé) printed: 28.09.2020

5. Product installation

5.1. Technical data AirLINE Quick

AirLINE Quick considerably reduces the use of components in the control cabinet. With the AirLINE Quick Adapter, the valve terminal is adapted directly to the control cabinet floor or wall.

Advantages:

- Reduced space requirement in the control cabinet
- This makes it possible to use more compact control cabinets
- Reduced installation effort due to hose connections directly at the bottom of the switch cabinet

Product properties

Material: AirLINE Quick Adapter	Stainless steel 1.4301 Aluminium anodized
Material: pneumatic connection	Stainless steel 1.4301 brass nickel-plated
Valve functions per station	8, 16, 24, 32, 40 and 48

Product connections

Connection: pneumatic feeding	G ¼, D ⅜"
Connection: pneumatic service ports	Push-in D6 mm, D ¼"

Environment and installation

Installation position	Wall control cabinet Floor control cabinet
-----------------------	---

AirLINE Quick Adapter in stainless steel 1.4301 or anodized aluminium

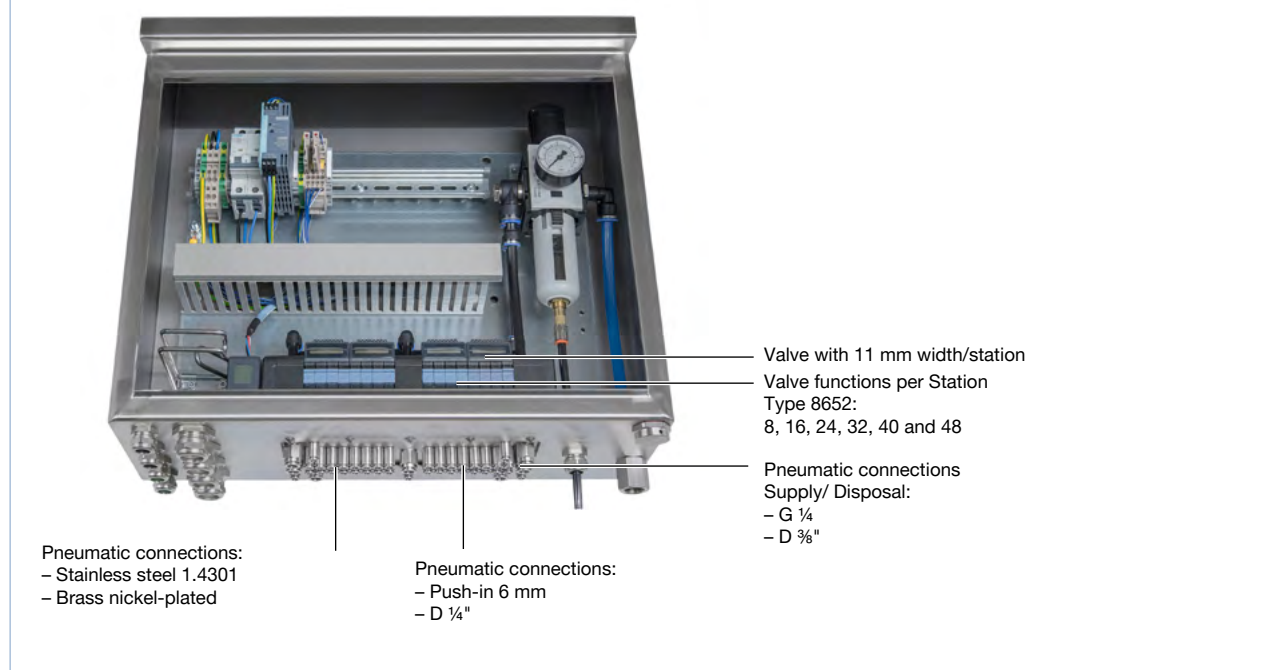

5.2. Installation notes

Installation situation of the valve terminal in the control cabinet

To be able to utilize the Hot Swap function always observe a minimum distance to the front edge of the control cabinet when installing the valve island in the control cabinet. Please also refer to the detailed description in the operating instructions.

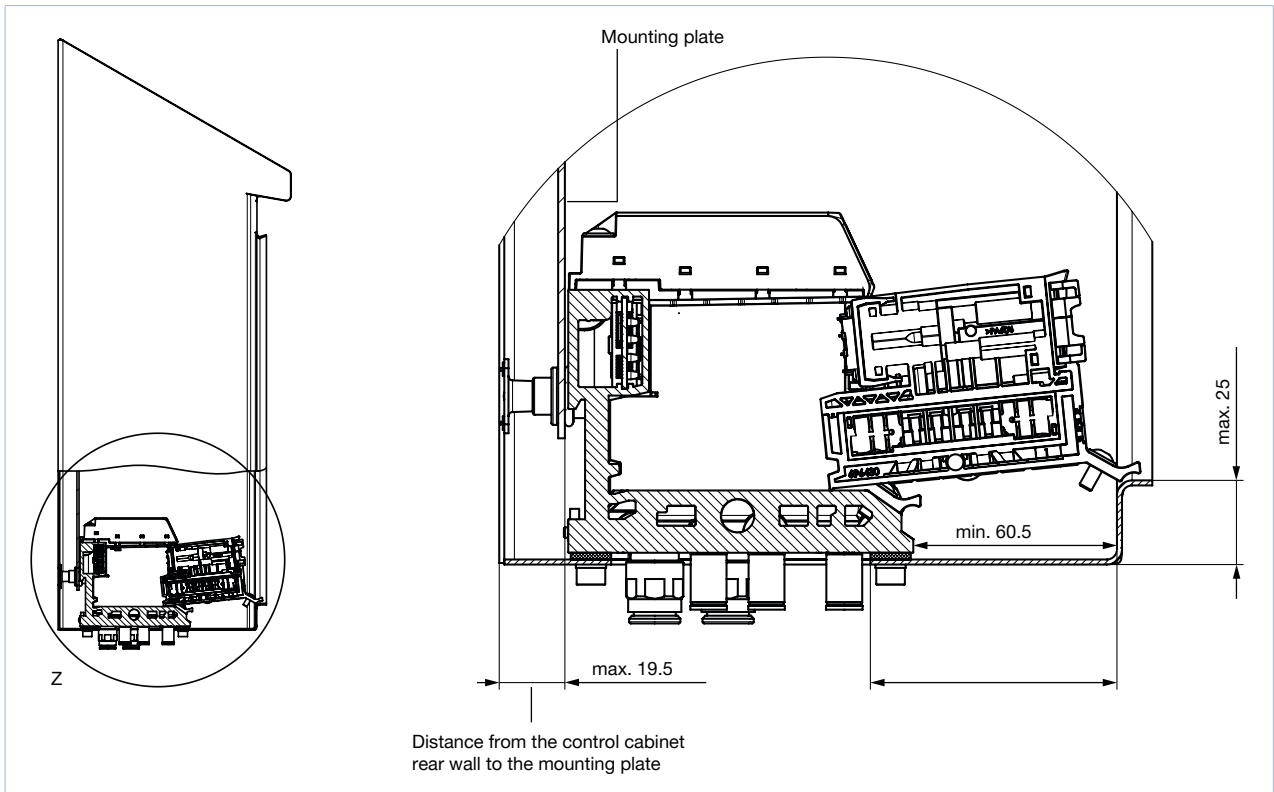

6. Product design and assembly

6.1. Product assembly

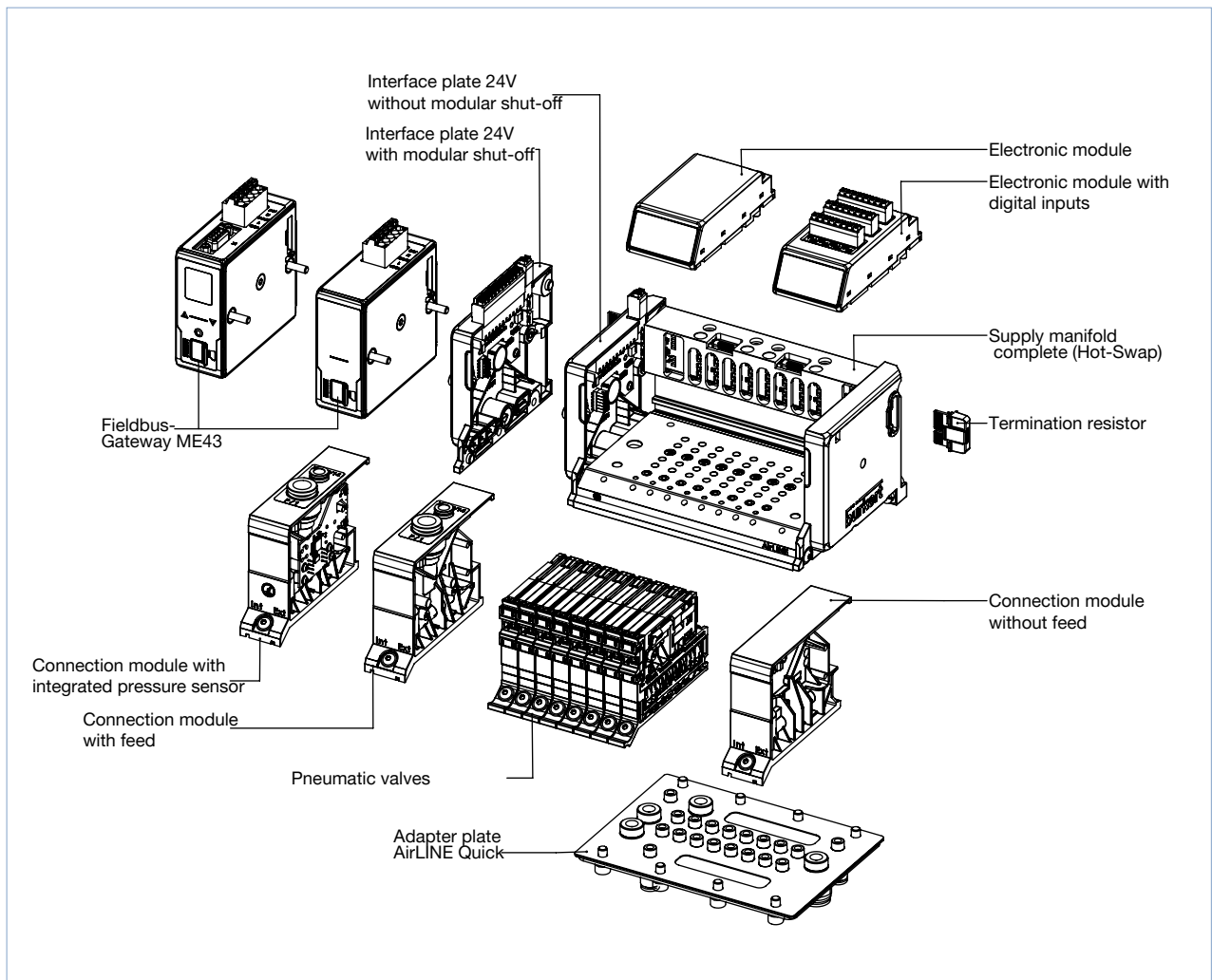

DTS 1000336890 EN Version: N Status: RL (released | freigegeben | valide) printed: 28.09.2020

6.2. Electronic module with digital inputs (optional)

The position feedbacks are supplied (24 V) by the electronic module. The current is limited to maximum 30 mA per position feedback. Standard 3-wire sensors and 2-wire sensors with voltages between 10...30 V as well as mechanical limit switches can be used.

Note:

- Connect position feedbacks according to the assignment on the electronic module.
- Possible cable cross-section: $\leq 1.5 \text{ mm}^2$
- Maximum cable length: <30 m

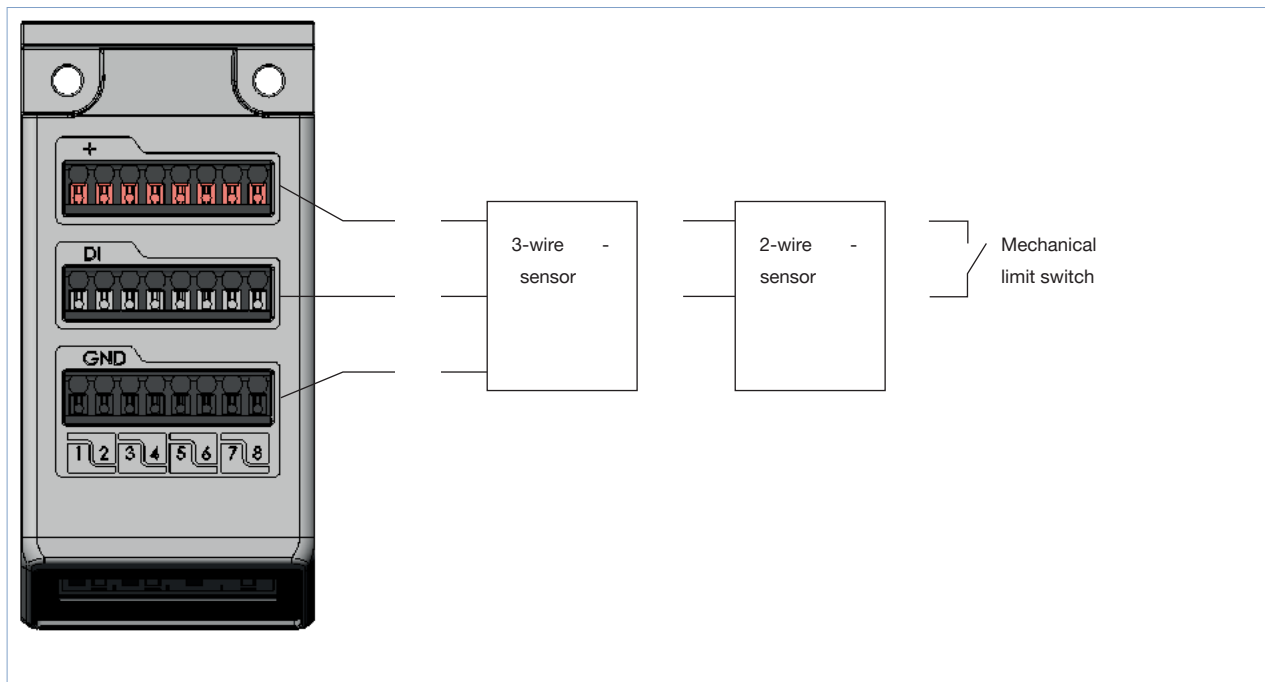

The following data may be output depending on the sensor used:

Possible data	3-wire sensors	2-wire sensors	Mechan. limit switches
Sensor actuated	X	X	X
Sensor not actuated	X	X	X
Short circuit	X	-	-
Broken wire	-	X	-

6.3. Valve Type 6534 for safety-related shut-off, SIA variant (optional)

Note:

Type 6534 valves for safety-related shut-off (SIA variant) are equipped with additional connection terminals. The circuit of a valve can therefore be interrupted by an external switch. Manual override is not required for these valve variants. The technical data of the Type 6534 SIA variant valves corresponds to the data of the standard device. To use the shut-off function, connect the connection to a potential-free contact (mechanical switch or relay). The switching contact must be located in the same control cabinet as the valve block. The line length must be limited to a maximum of 2 m.

	<p>The yellow connection terminals are pluggable and can be removed to facilitate connection of a cable. Except for CFH, there are always 2 connection terminals. To avoid mixing up the connections, the connection terminals are coded.</p> <p>On delivery, the connection terminals are provided with a bridge to ensure the valve can be put into operation immediately. Remove the bridge before connecting a cable.</p>
--	---

<p>Connection terminals:</p>	<p>Pluggable screw-type terminal, 2 pin, coded wire cross-section (rigid or flexible) 0.14 mm²...1.5 mm² (AWG 28...16)</p>
<p>Required switching capacity of the contact:</p>	<p>0.5 A / 24 V DC</p>

Connection designation	Circuit diagram											
	<table border="1"> <tr> <td>Electrical connection valve</td> <td>Potential free contact</td> <td>Coil</td> </tr> <tr> <td>12 (+) 24 V ==</td> <td rowspan="2">Connection terminal 12</td> <td rowspan="2">12</td> </tr> <tr> <td>12 (-)</td> </tr> <tr> <td>14 (+) 24 V ==</td> <td rowspan="2">Connection terminal 14</td> <td rowspan="2">14</td> </tr> <tr> <td>14 (-)</td> </tr> </table>	Electrical connection valve	Potential free contact	Coil	12 (+) 24 V ==	Connection terminal 12	12	12 (-)	14 (+) 24 V ==	Connection terminal 14	14	14 (-)
Electrical connection valve	Potential free contact	Coil										
12 (+) 24 V ==	Connection terminal 12	12										
12 (-)												
14 (+) 24 V ==	Connection terminal 14	14										
14 (-)												

Connection designation	Circuit diagram							
	<table border="1"> <tr> <td>Electrical connection valve</td> <td>Potential free contact</td> <td>Coil</td> </tr> <tr> <td>14 (+) 24 V ==</td> <td rowspan="2">Connection terminal 14</td> <td rowspan="2">14</td> </tr> <tr> <td>14 (-)</td> </tr> </table>	Electrical connection valve	Potential free contact	Coil	14 (+) 24 V ==	Connection terminal 14	14	14 (-)
Electrical connection valve	Potential free contact	Coil						
14 (+) 24 V ==	Connection terminal 14	14						
14 (-)								

DTS 1000336890 EN Version: N Status: RL (released | freigegeben | validé) printed: 28.09.2020

6.4. Module-based safety shutdown (optional)



To use the switch-off function, connect the connection to a potential-free contact (mechanical switch or relay). The contact must be located in the same control cabinet as the valve terminal, but limit the cable length to a maximum of 2 m.

Connection:	Pluggable spring-loaded terminal*, 12 pin Conductor cross-section (rigid or flexible) 0.14 mm ² ...1.5 mm ² (AWG 26...16)
Required switching capacity of the contact:	1.5 A / 24 V DC

7. Ordering information

7.1. Bürkert eShop – Easy ordering and quick delivery

Bürkert eShop – Easy ordering and fast delivery

You want to find your desired Bürkert product or spare part quickly and order directly? Our online shop is available for you 24/7. Sign up and enjoy all the benefits.

[Order online now](#)

7.2. Bürkert product filter









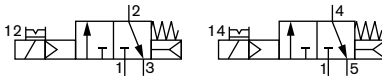

Bürkert product filter – Get quickly to the right product

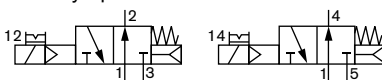
You want to select products comfortably based on your technical requirements? Use the Bürkert product filter and find suitable articles for your application quickly and easily.

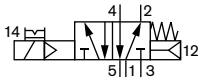
[Try out our product filter](#)

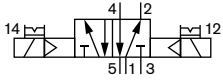
7.3. Ordering chart spare valves

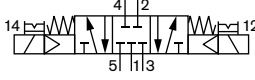
Standard version







Circuit function	Nominal diameter/ Orifice	Q _{Nn} value ^{1.)} Air	Pressure range	Switching times		Voltage/ Frequency	Article no. ^{2.)} incl. screw
				Opening [ms]	Closing [ms]		
C, solenoid valve 2 × 3/2 way Servo-controlled, with manual override Normally closed 	4	270 l/min	Vac. 10 ^{3.)} 3...10	15	15	24 V DC	301374 
D, solenoid valve 2 × 3/2 way Servo-controlled, with manual override Normally open 	4	310 l/min	Vac. 10 ^{3.)} 3...10	15	15	24 V DC	301375 
H, solenoid valve 5/2 way Servo-controlled, with manual override, with auxiliary pilot air Normally open 	4	290 l/min	Vac. 10 ^{3.)} 3...10	20	25	24 V DC	301376 
Z, solenoid valve 5/2 way Impulse version with 2 coils, with manual override Normally open 	4	290 l/min	Vac. 10 ^{3.)} 3...10	20	25	24 V DC	301377 
L, solenoid valve 5/3 way Centre position all connections locked, with manual override Normally closed 	4	275 l/min	Vac. 10 ^{3.)} 3...10	15	15	24 V DC	301380 
Dummy valve	–	–	–	–	–	–	335779 

1.) With HotSwap function approx. 3% flow reduction

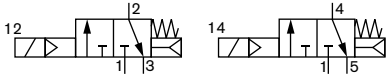
2.) The valves are components or spare parts of the Type 8652 Valve Terminal and can only be used on the Type 8652 Valve Terminal.

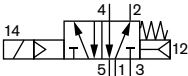
3.) Separate auxiliary control air min. 3 bar, please consider control pressure table in operating instructions.

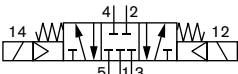
Second port for shutdown (SIA variant)

Circuit function	Nominal diameter/ Orifice	Q _{Nn} value ^{1.)} Air	Pressure range	Switching times		Voltage/ Frequency	Article no. ^{2.)} incl. screw
	[mm]	[l/min]	[bar]	Opening [ms]	Closing [ms]	[V/Hz]	
C, solenoid valve 2 × 3/2 way Servo-controlled Normally closed 	4	270 l/min	Vac. 10 ^{3.)} 3...10	15	15	24 V DC	338802 
H, solenoid valve 5/2 way Servo-controlled Normally open 	4	290 l/min	Vac. 10 ^{3.)} 3...10	20	25	24 V DC	338805 
L, solenoid valve 5/3 way Centre position all connections locked Normally closed 	4	275 l/min	Vac. 10 ^{3.)} 3...10	15	15	24 V DC	346830 

1.) With HotSwap function approx. 3 % flow reduction

2.) The valves are components or spare parts of the Type 8652 Valve Terminal and can only be used on the Type 8652 Valve Terminal.

3.) Separate auxiliary control air min. 3 bar, please consider control pressure table in operating instructions.

