

По вопросам продаж и поддержки обращайтесь:

Архангельск (8182)63-90-72	Краснодар (861)203-40-90	Рязань (4912)46-61-64
Астана (7172)727-132	Красноярск (391)204-63-61	Самара (846)206-03-16
Белгород (4722)40-23-64	Курск (4712)77-13-04	Санкт-Петербург (812)309-46-40
Брянск (4832)59-03-52	Липецк (4742)52-20-81	Саратов (845)249-38-78
Владивосток (423)249-28-31	Магнитогорск (3519)55-03-13	Смоленск (4812)29-41-54
Волгоград (844)278-03-48	Москва (495)268-04-70	Сочи (862)225-72-31
Вологда (8172)26-41-59	Мурманск (8152)59-64-93	Ставрополь (8652)20-65-13
Воронеж (473)204-51-73	Набережные Челны (8552)20-53-41	Тверь (4822)63-31-35
Екатеринбург (343)384-55-89	Нижний Новгород (831)429-08-12	Томск (3822)98-41-53
Иваново (4932)77-34-06	Новокузнецк (3843)20-46-81	Тула (4872)74-02-29
Ижевск (3412)26-03-58	Новосибирск (383)227-86-73	Тюмень (3452)66-21-18
Казань (843)206-01-48	Орел (4862)44-53-42	Ульяновск (8422)24-23-59
Калининград (4012)72-03-81	Оренбург (3532)37-68-04	Уфа (347)229-48-12
Калуга (4842)92-23-67	Пенза (8412)22-31-16	Челябинск (351)202-03-61
Кемерово (3842)65-04-62	Пермь (342)205-81-47	Череповец (8202)49-02-64
Киров (8332)68-02-04	Ростов-на-Дону (863)308-18-15	Ярославль (4852)69-52-93

Единый адрес: btk@nt-rt.ru **Веб-сайт:** www.burkert.nt-rt.ru

РАСХОДОМЕРЫ ЖИДКОСТИ И ГАЗА

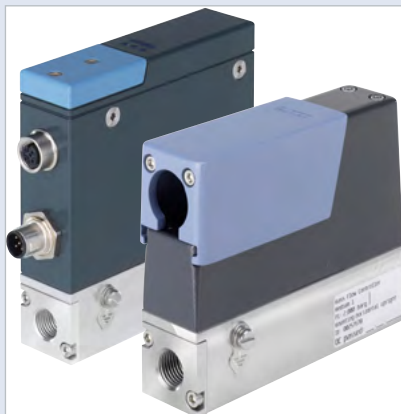

Mass Flow Controller (MFC)/ Mass Flow Meter (MFM) for gases

- Nominal flow ranges from 0.010 I_N/min to 160 I_N/min
- Highest measuring accuracy and repeatability with very fast response times
- Long-term stability of the flow calibration
- Easy device exchange due to configuration memory
- Optional: ATEX II Cat. 3G/D or USP Class VI, FDA, EG 1935 conformity

Product variants described in the data sheet may differ from the product presentation and description.

Can be combined with



Type 6011
Plunger valve 2/2 way direct-acting



Type 6013
Plunger valve 2/2 way direct-acting



Type 6027
Direct-acting 2/2 way plunger valve



Type 0330
Direct-acting 2/2 or 3/2-way pivoted armature valve



Type ME43
Fieldbus gateway



Type ME63 ▶
Industrial Ethernet gateway, IP65/ IP67/ IP69k

Type description

The Mass Flow Controller (MFC) / Mass Flow Meter (MFM) Type 8742 for gases is suitable for a wide range of applications, e.g. metal and glass manufacturing or processing, fermentation processes, test benches or filling systems and packaging machines. Type 8742 is available in two variants: The variant with several analogue or digital (communication) interfaces and the variant with only a CANopen-based interface. The latter is suitable for integration into existing CANopen networks or - in combination with the fieldbus gateway Type ME43 - for integration in all common industry standards for Industrial Ethernet or fieldbus. This variant is tailor-made for applications with many control loops. Up to 32 MFCs/ MFMs can be connected to one fieldbus gateway. Type ME43 transmits the internal CANopen-based communication to Industrial Ethernet and fieldbus standards. The Mass Flow Controller / Mass Flow Meter can always be switched between bÜS and CANopen communication. Type 8742 can be configured as required as an MFM or MFC. Optionally, up to four calibration curves can be stored in the device. The thermal MEMS sensor is located directly in the gas flow and achieves very fast response times and the highest level of measuring accuracy, with long-term stable calibration. As the actuator, a Bürkert direct-acting proportional valve guarantees high response sensitivity. The integrated PI controller ensures excellent control characteristics of the MFC. Type 8742 is especially designed for use in harsh environments thanks to its high IP protection class and explosion protection.

1. General Technical Data





Product properties	
Materials	
Body	Stainless steel or aluminium
Housing	Aluminium die casting (coated)
Seal	FKM or EPDM (depending on gas)
Dimensions	See “4. Dimensions” on page 4
Total weight	approx. 950 g (stainless steel body)
Configuration memory (included in delivery)	EEPROM (µSIM card: stores all parameters (e.g. individual fieldbus or controller settings) relevant for device replacement without software tool)
LED display	RGB-LED based on NAMUR NE107
Performance data	
Nominal flow range (Q_{Nom})	10 ml _N /min...160 l _N /min (N ₂)
Measuring range	1:50, optional 1:100
Max. operating pressure	10 bar (145 psi), for MFCs the max. pressure depends on the orifice of the valve
Measuring accuracy	±0.8 % o.R. ±0.3 % F.S. (after 1 min warm up time)
Repeatability	±0.1 % F.S.
Settling (MFC)/response (MFM) time ($t_{95\%}$)	<300 ms
Control valve (prop. valve)	Normally closed
Valve orifice range	0.05...8 mm
k_{VS} value range	0.00006...1.1 m ³ /h
Electrical data	
Operating voltage	24 V DC
Power consumption ^{1.)}	1 W (as MFM) Max. 3...17.5 W (as MFC, depending on type of solenoid control valve)
Voltage tolerance	±10 %
Residual ripple	±2 %
Electrical connection	M12 plug, 5 pin
Medium data	
Operating medium	Neutral, non-contaminated gases, others on request
Calibration medium	Operating gas or air
Medium temperature	-10 °C...+70 °C (-10 °C...+60 °C with oxygen)
Process/Port connection & communication	
Port connection	NPT ¼, G ¼, Sub-base, compression or vacuum fitting, others on request
Digital (communication) interfaces	CANopen or CAN based bus or PROFIBUS-DP
Analogue interfaces	4...20 mA, 0...20 mA, 0...10 V or 0...5 V Input impedance >20 kΩ (Voltage) o.R. <300 Ω (Current) Max. Current: 10 mA (Voltage output); max. Load: 600 Ω (Current output)
Environment and installation	
Installation position	Horizontal or vertical
Ambient temperature	-10 °C...+50 °C (higher temperatures on request)
Degree of protection	IP65 and IP67
Accessories	
Software-Tool	Bürkert Communicator Detailed information can be found in chapter “9.1. Bürkert Communicator Software” on page 16 .

1.) Data refers to the typical power consumption (at 23 °C ambient temperature, nominal flow rate and 30 min. control mode). The specifications according to UL 61010-1 can differ (see Operating Manual).

2. Approvals

Note:

- The approvals and conformities listed below must be stated when making enquiries. This is the only way to ensure that the product complies with all required specifications.
- Not all available types can be supplied with the approvals or conformities below.

Approvals	Description
	UL Listed according to DIN EN 61010-1 for USA and Canada
	Conformity of all materials in contact with the medium USP Class VI chapter "87 in vitro" and „88 in vivo, Implantation“
FDA	Conformity of all materials in contact with the medium FDA – Code of Federal Regulations Title 21 Paragraph 177 (CFR 21 177.2600)
	Conformity of all materials in contact with the medium Regulation (EC) No. 1935/2004 on materials and objects intended to come into contact with food
	ATEX ATEX/ IECEX: II 3G Ex nA IIC T* Gc X and II 3D Ex tc IIIC T***C Dc X acc. to DIN EN 60079-0 and DIN EN 60079-15, T3/4 and T160 °C/135 °C depending on device variant

3. Materials

3.1. Chemical Resistance Chart – Bürkert resistApp

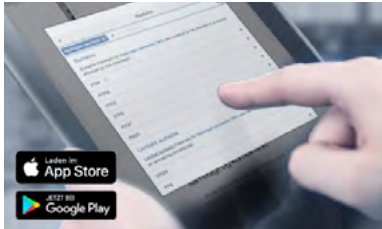

Bürkert resistApp – Chemical Resistance Chart

You want to ensure the reliability and durability of the materials in your individual application case? Verify your combination of media and materials on our website or in our resistApp.

[Start Chemical Resistance Check](#)

4. Dimensions

Note:

The following table applies to the following dimensions.

A	Thread depth [mm]
G ¼	12
NPT ¼	11
G ⅜	12
NPT ⅜	11
G ½	15
NPT ½	14
G ¾	16
NPT ¾	15

4.1. Devices with bus/CANopen interface

MFM or MFC with internal valve (Type 2871)

Note:

Dimensions in mm

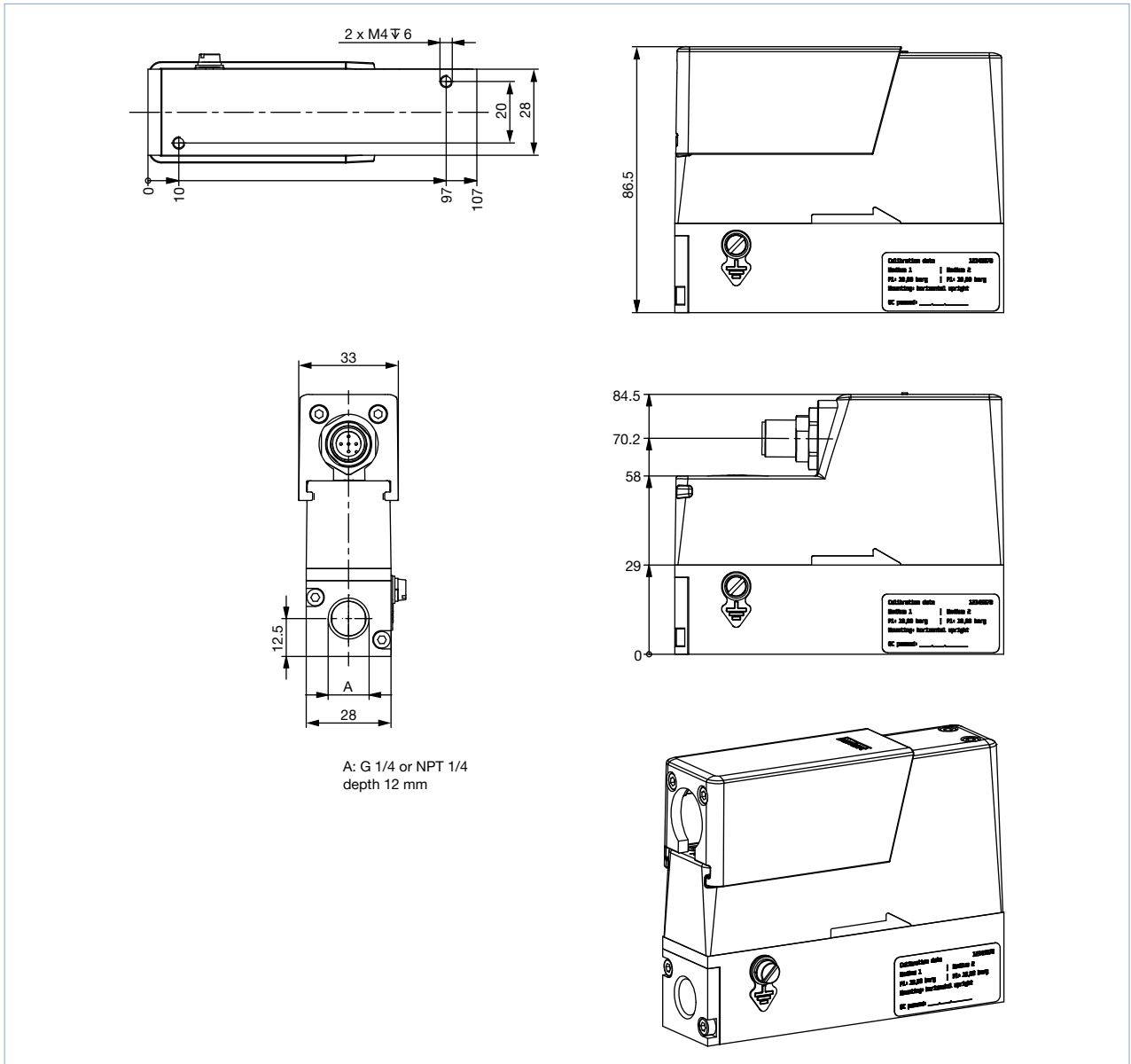

MFM or MFC with internal valve (Type 2871), sub-base version

Note:

Dimensions in mm

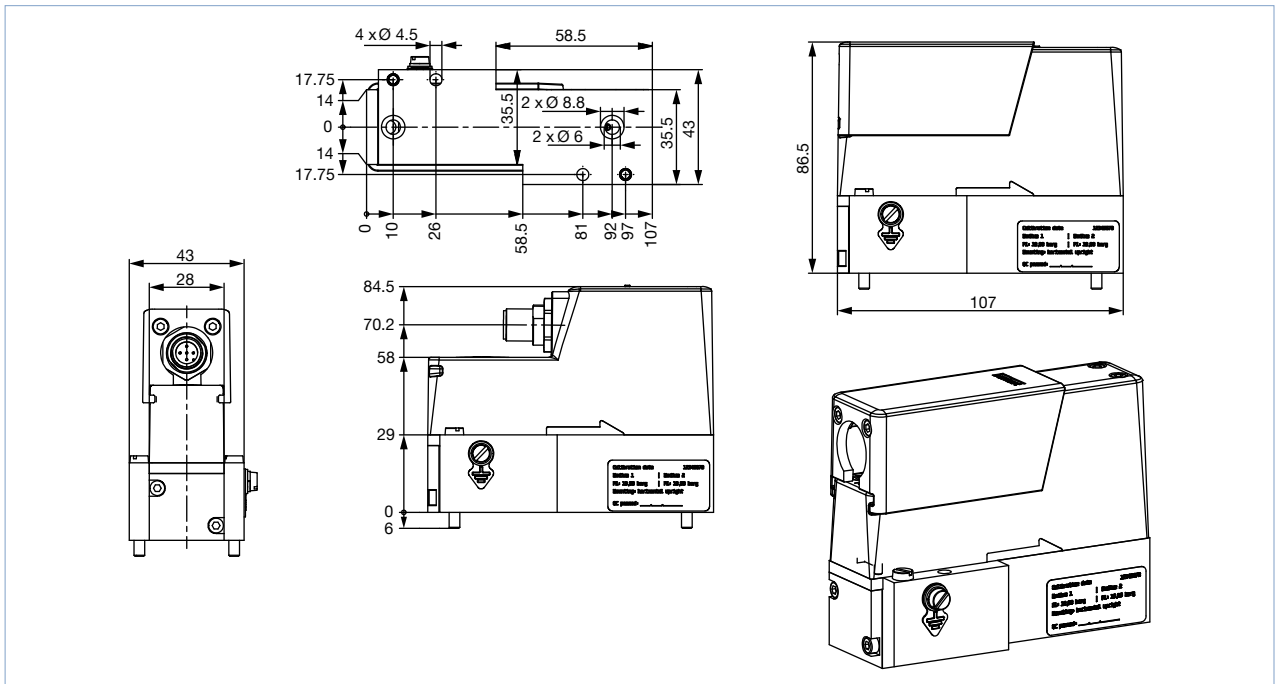

MFC with external valve (Type 2873)

Note:

Dimensions in mm

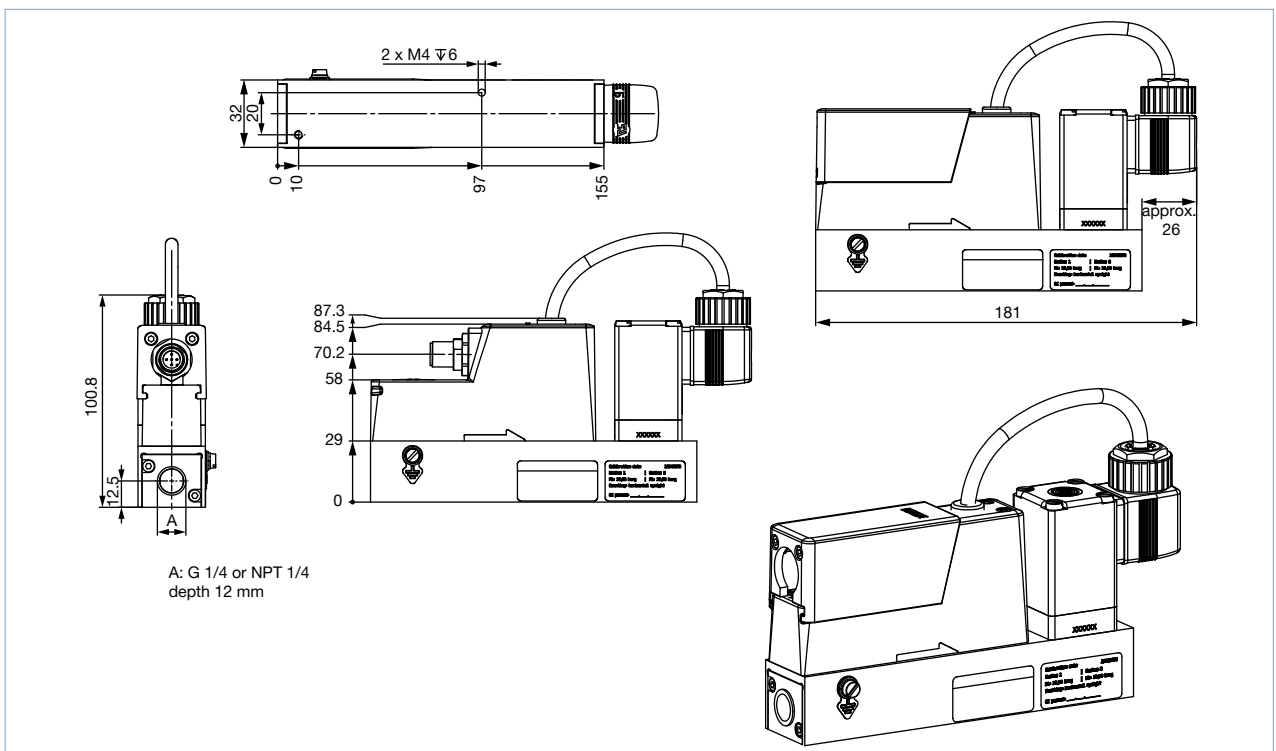

MFM for high nominal flow rates

Note:

Dimensions in mm

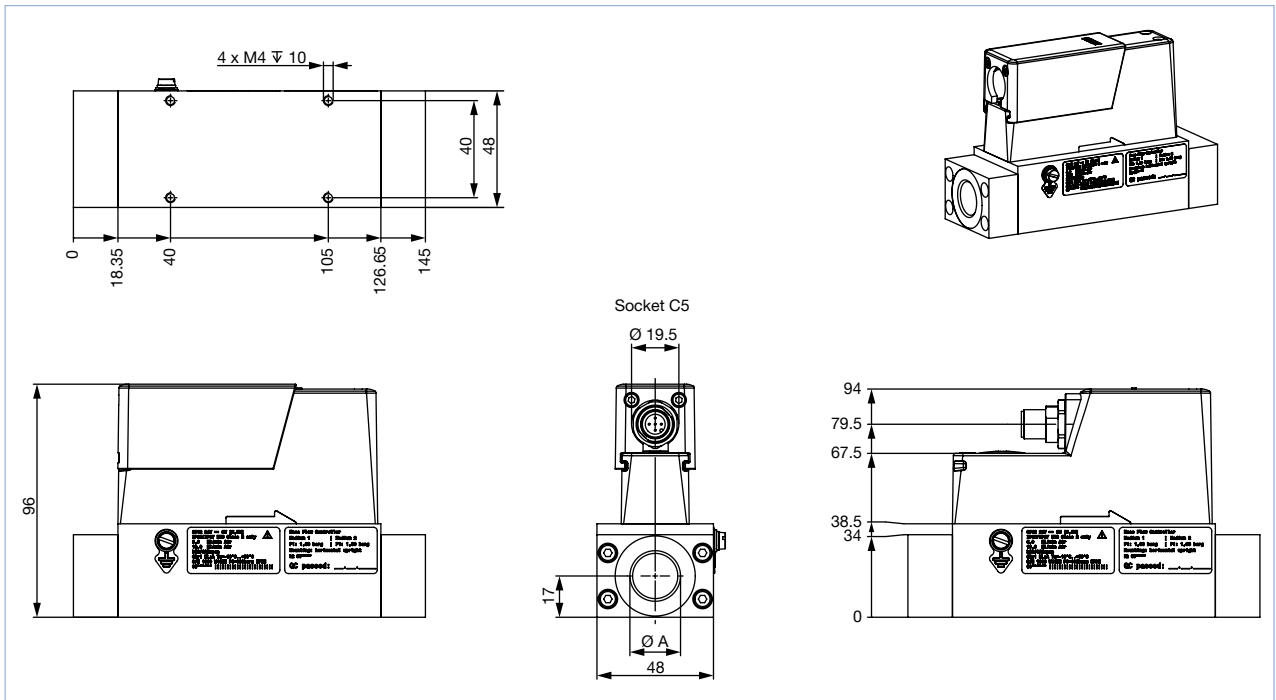

MFC with external valve (Type 2873) for high nominal flow rates

Note:

Dimensions in mm

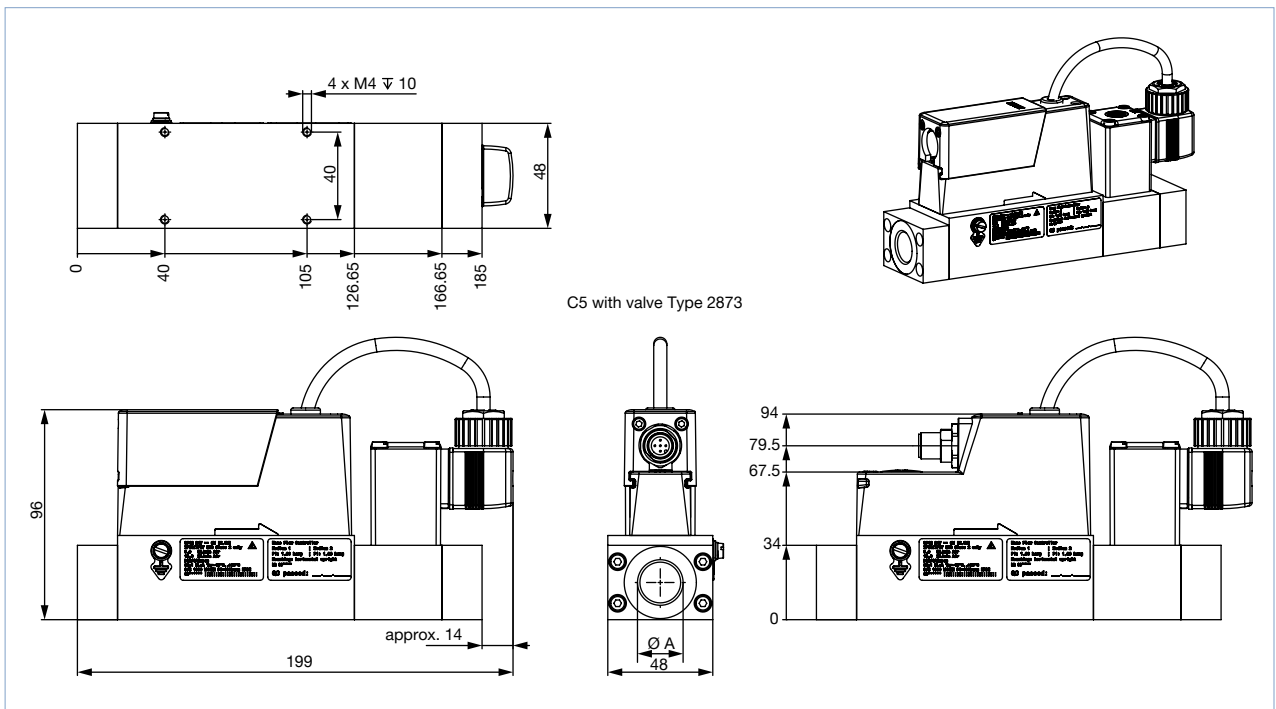

DTS 1000236628 EN Version: T Status: RL (released | freigegeben | valide) printed: 28.05.2021

MFC with external valve (Type 2875) for high nominal flow rates

Note:

Dimensions in mm

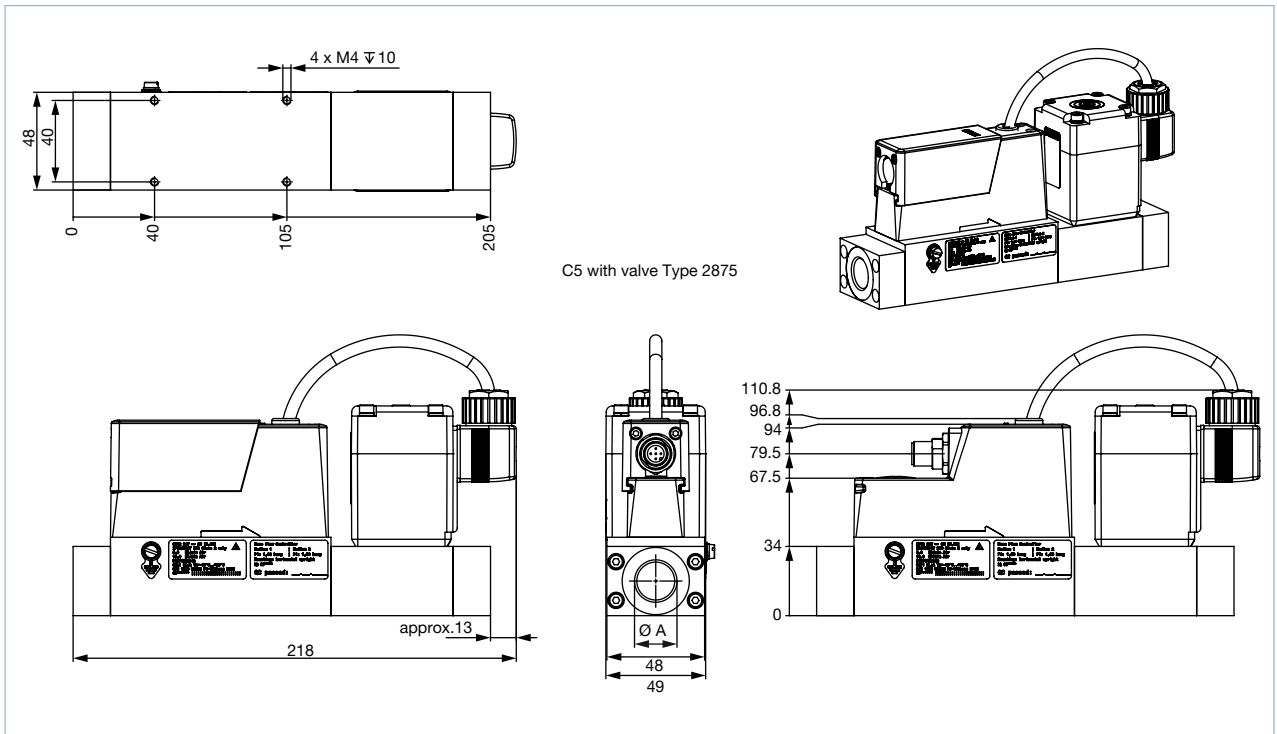

4.2. Devices with analog or PROFIBUS-DP interface

MFM or MFC with internal valve (Type 2871)

Note:

Dimensions in mm

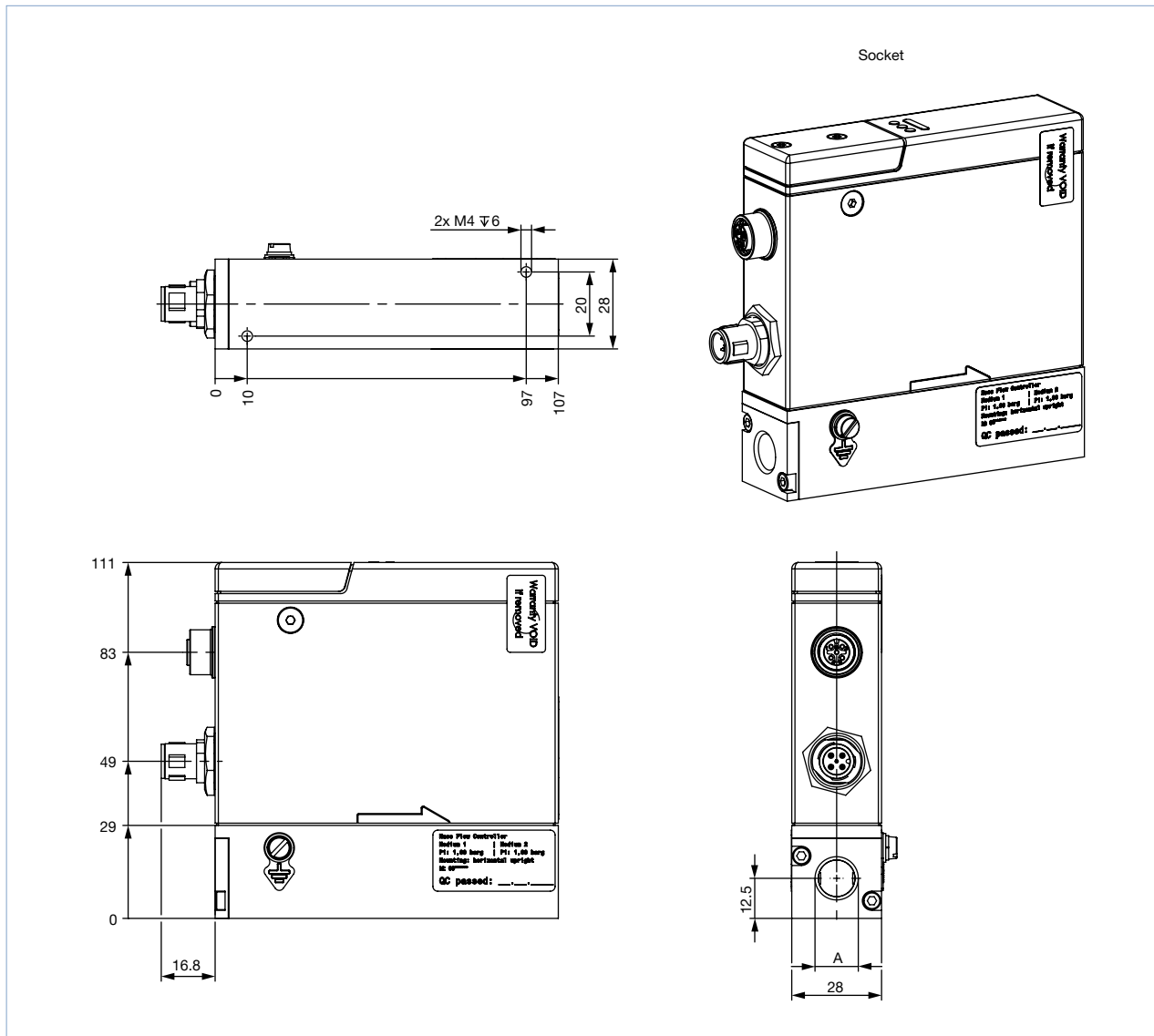

MFM or MFC with internal valve (Type 2871), sub-base version

Note:

Dimensions in mm

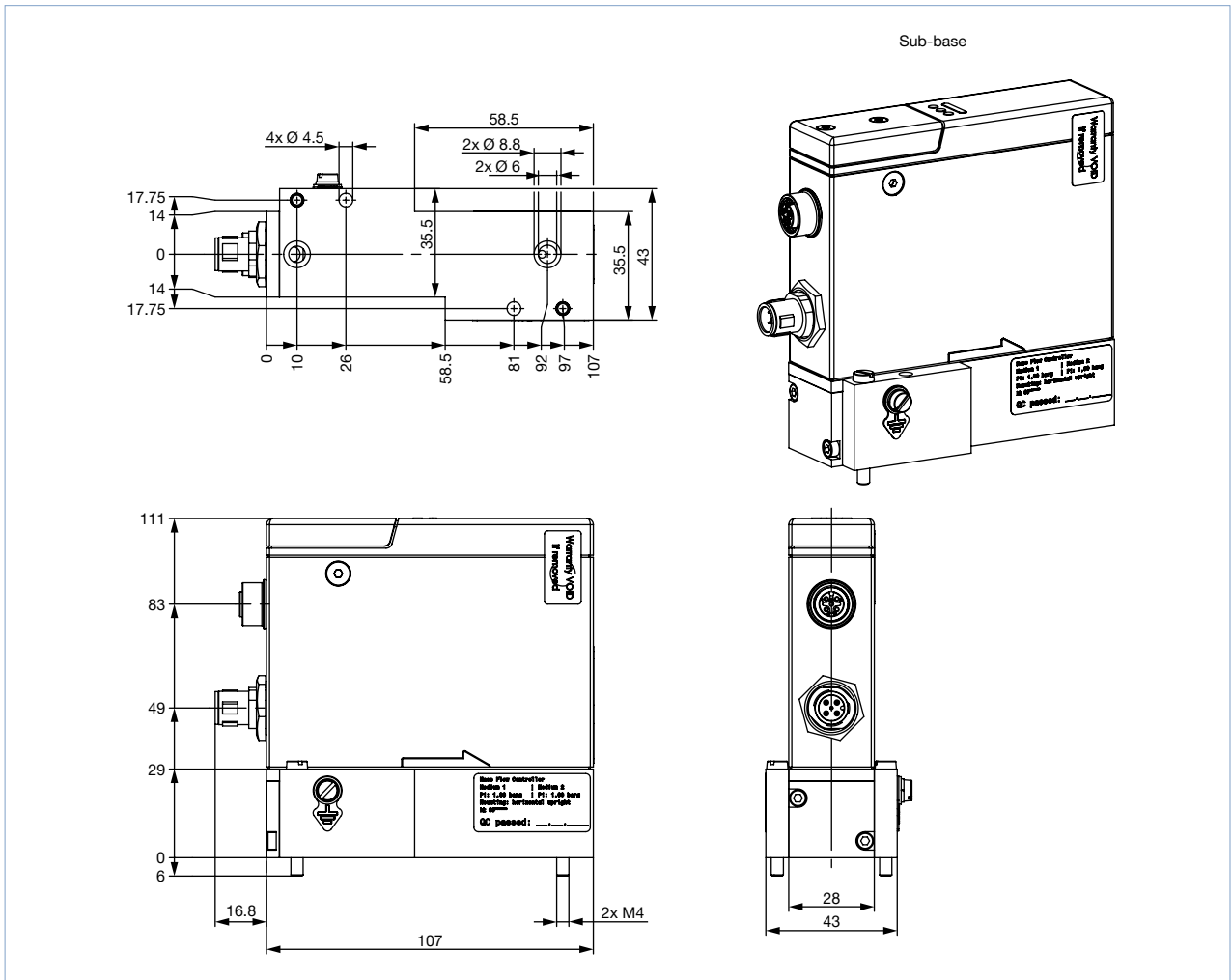

MFC with external valve (Type 2873)

Note:

Dimensions in mm

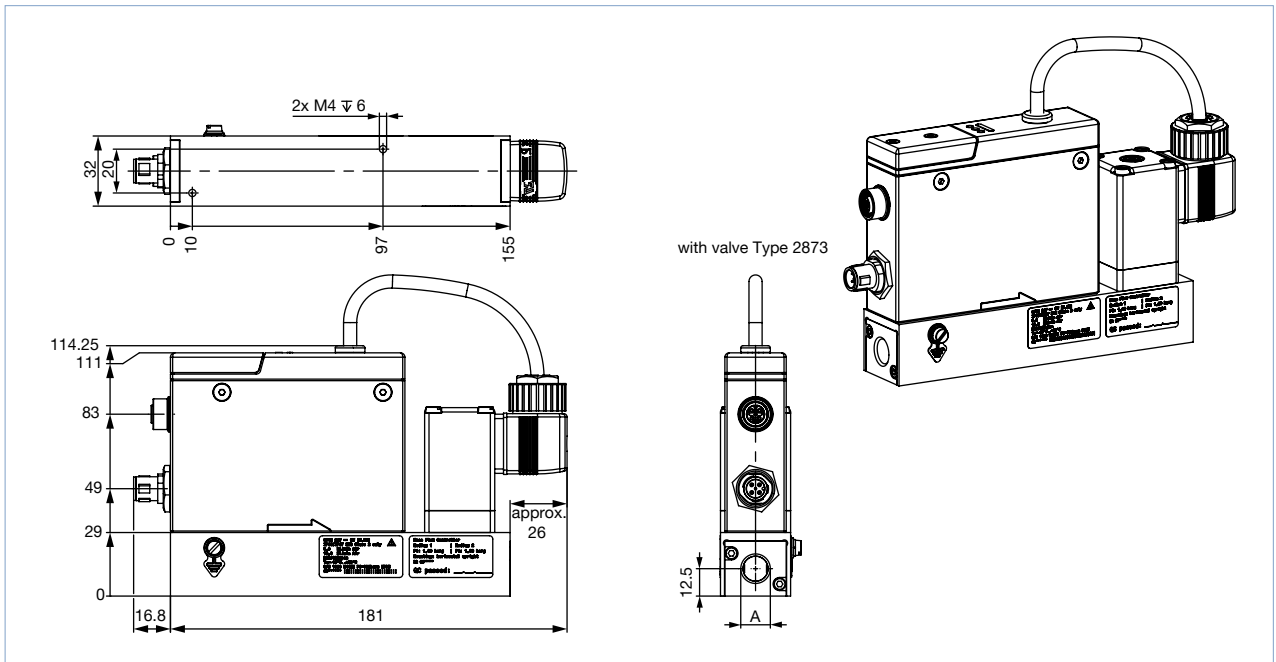

MFM for high nominal flow rates

Note:

Dimensions in mm

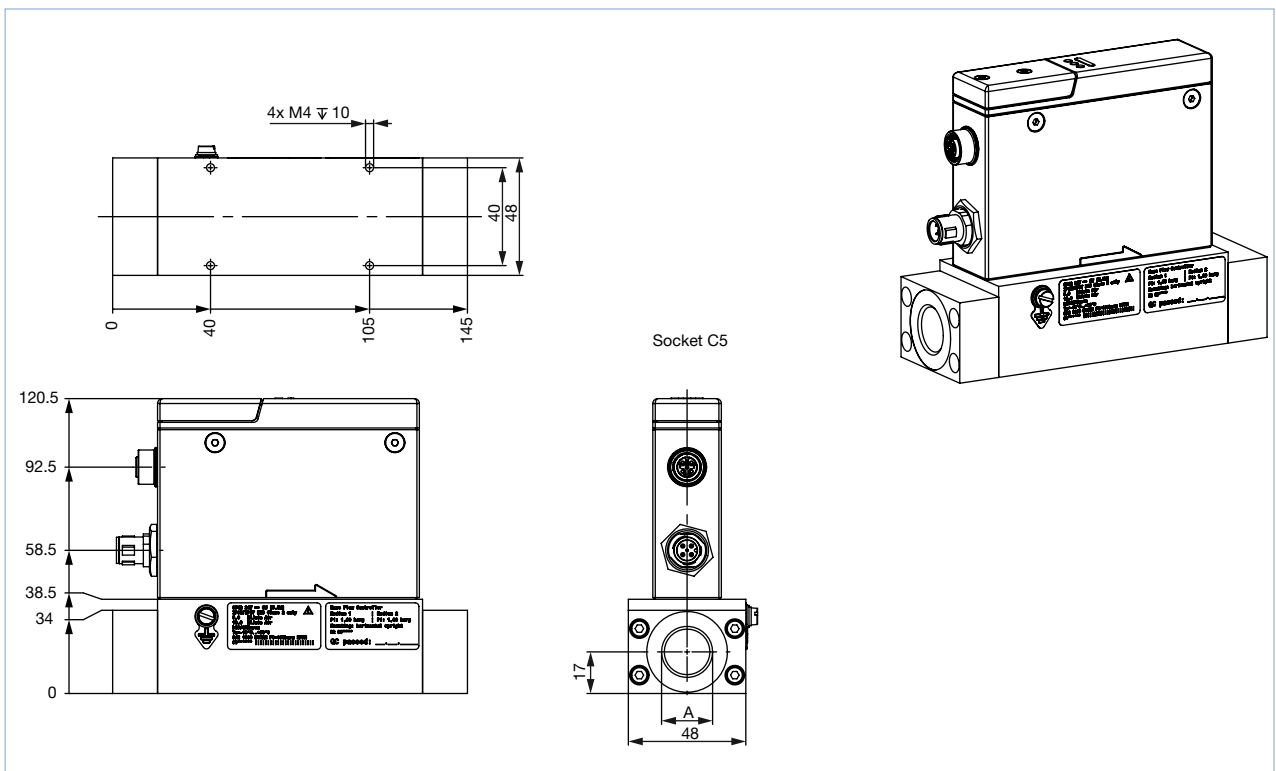

MFC with external valve (Type 2873) for high nominal flow rates

Note:

Dimensions in mm

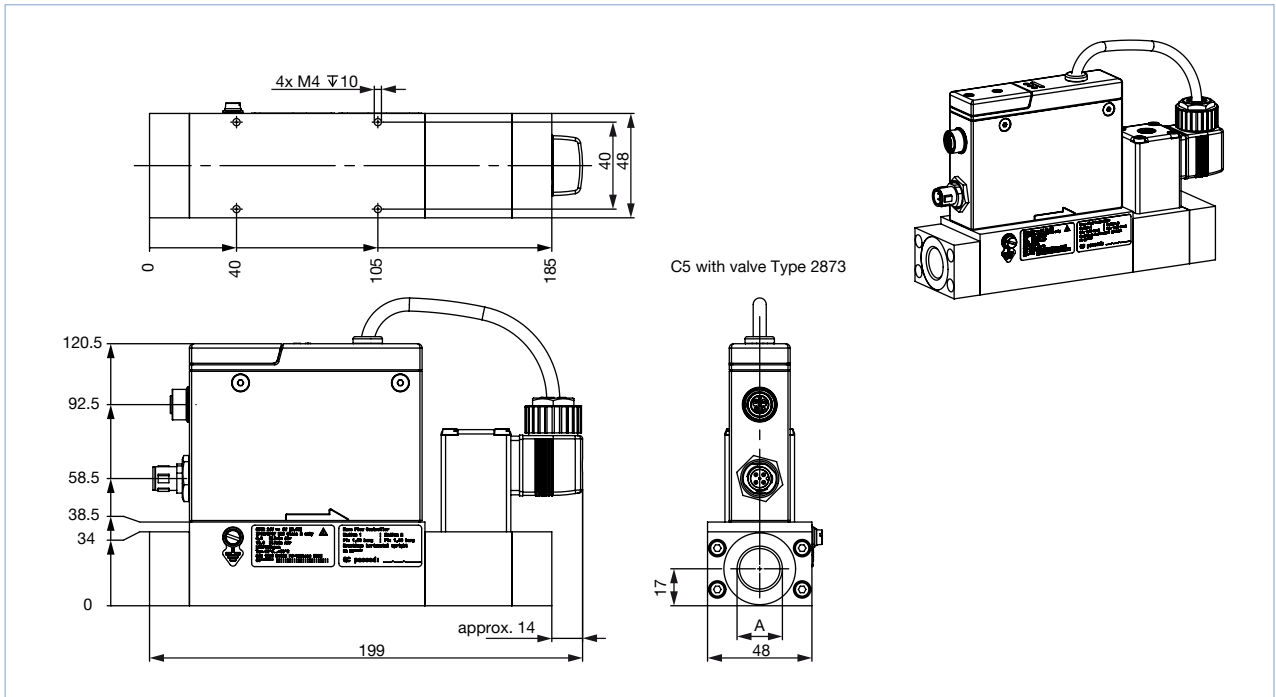

MFC with external valve (Type 2875) for high nominal flow rates

Note:

Dimensions in mm

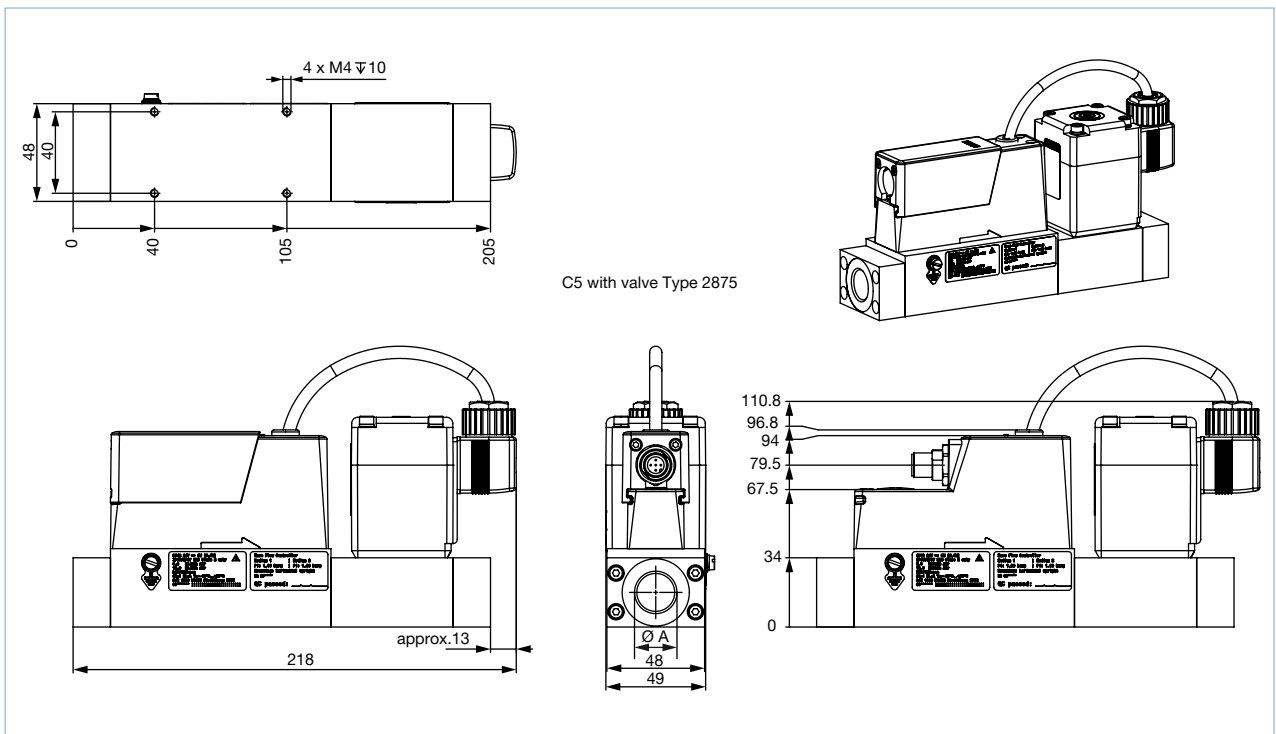

DTS 1000236628 EN Version: T Status: RL (released | freigegeben | valide) printed: 28.05.2021

5. Device/Process connections

5.1. CANopen or CANopen-based büS

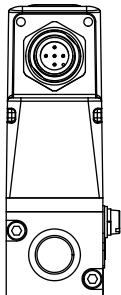

M12 lug, 5 pin (A-coded)	Pin	Configuration
	1	Shield
	2	24 V
	3	DGND
	4	CAN_H
	5	CAN_L

5.2. Analogue

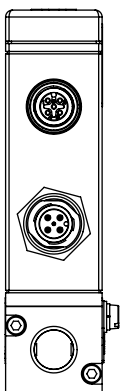

M12 socket, 5 pin (A-coded)	Pin	Configuration
	1	Digital input GND
	2	Digital input +
	3	Relay, Reference contact
	4	Relay, normally closed contact (Break contact)
	5	Relay normally open contact (Make contact)

M12 plug, 5 pin (A-coded)	Pin	Configuration
	1	Set value input GND (not connected for MFM)
	2	24 V
	3	GND
	4	Set value input (not connected for MFM)
	5	Analogue output for the measured value

5.3. PROFIBUS-DP

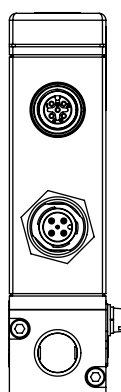

M12 socket, 5 pin (B-coded)	Pin	Configuration
	1	5 V
	2	RxD / TxD (Line A)
	3	DGND
	4	RxD / TxD (Line B)
	5	Not connected

M12 plug, 5 pin (A-coded)	Pin	Configuration
	1	Shield
	2	24 V
	3	GND
	4	Not connected
	5	Not connected

DTS 1000236628 EN Version: T Status: RL (released | freigegeben | valide) printed: 28.05.2021

6. Performance specifications

6.1. Pressure Loss Diagram of the MFM

The diagram shows an example of the pressure loss characteristics when air flows through. To determine the pressure loss of another gas, the corresponding air equivalent must first be calculated and the basic fluidics used for the other gas taken into account.

Chip Sensor up to 160 l_N/min

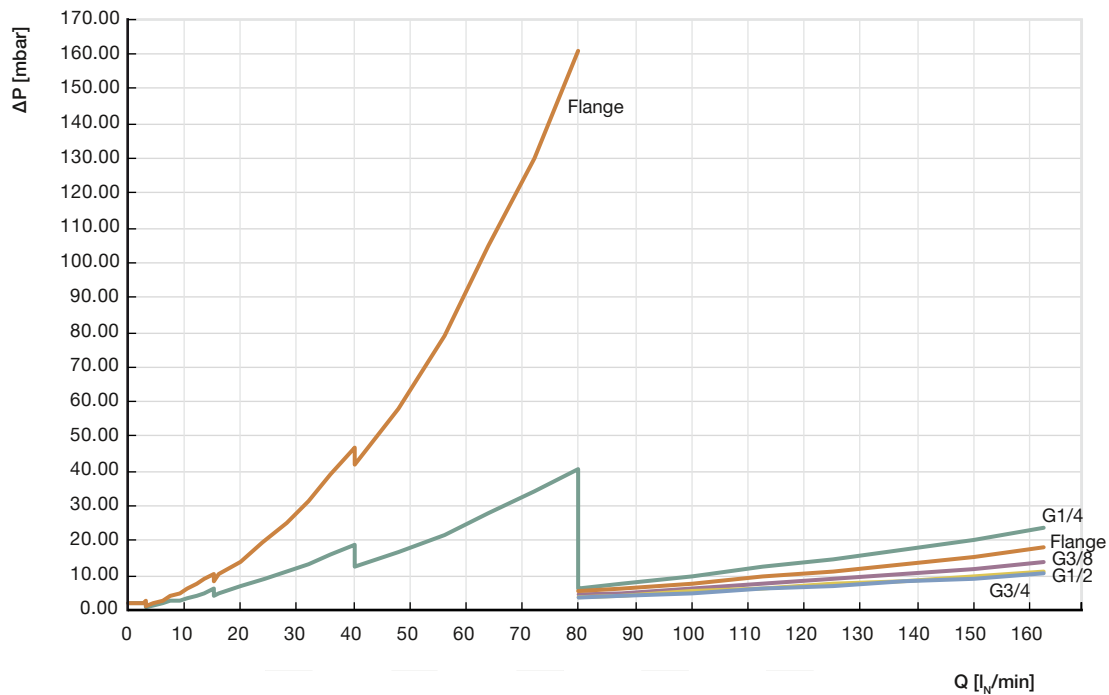

6.2. Flow characteristic

Nominal flow range of typical gases

Note:

- All values refer to 1.013 bara and 0 °C (Index N)
- Other gases and gas mixtures on request

Gas	Min. Q _{Nom}	Max. Q _{Nom}
	[l _N /min]	[l _N /min]
Argon	0.01	160
Acetylene	0.01	65
Helium	0.01	1000
Carbon dioxide	0.02	80
Air	0.01	160
Methane	0.01	160
Propane	0.03	44
Oxygen	0.01	160
Nitrogen	0.01	160
Hydrogen	0.01	1000

7. Product operation

7.1. Measuring principle

The flow measurement takes place directly in the bypass channel.

A laminar flow element in the main channel generates a small pressure drop, which drives a small part of the total flow through the bypass channel. The sensor is located there and measures the mass flow directly as a temperature difference. The measurement is performed in a specially shaped flow channel, the wall of which contains a Si chip with an etched membrane at one point. A heating resistor and, symmetrically to this, two temperature sensors, one upstream and one downstream, are placed on this membrane. If the heating resistor is fed with a constant voltage, the differential voltage of the temperature sensors is a measure for the mass flow of the gas flowing over the chip in the flow channel.

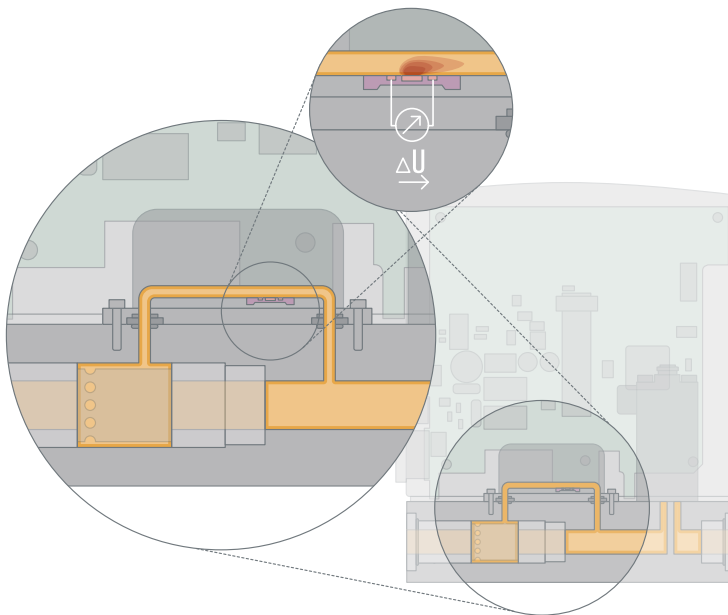

8. Product design and assembly

8.1. Product features

Measures to comply with ATEX requirements

Note:

Devices with ATEX conformity meet protection class IP65.

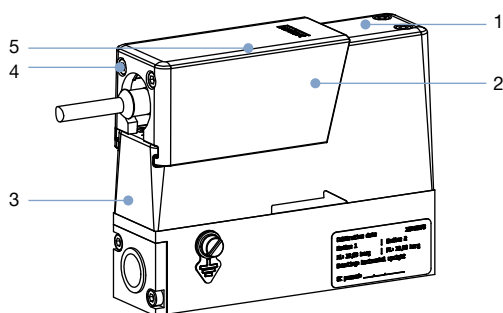

No.	Description
1	Standard requirements for cable glands are fulfilled for versions with external valve.
2	M12 plug achieves protection class IP65 and IP67 with and without mounted counterpart.
3	Die-cast housing receives IP protection under high mechanical stress.
4	Screws prevent uncoupling of the M12 connection under tension.
5	Impact protection cap prevents damage of the M12 plug and all connected elements if mechanical stress is applied. No particular ATEX sockets are required.

9. Product accessories

9.1. Bürkert Communicator Software

Note:

To install the software, click [here](#) ►.

Part of Bürkert's EDIP program (Efficient Device Integration Platform) is the Bürkert Communicator. This software can be run under MS-Windows and it is available on Bürkert's website for free. The Bürkert Communicator allows convenient system configuration and parametrisation of all connected field devices. An accessory part, the bÜS stick serves as the interface between computer and process instruments (see "10.4. Ordering chart accessories" on page 17). It transfers "USB data" to "CAN data". The Communicator allows:

- Diagnosis
- Parametrization
- Registration and storage of process data
- To watch graph of process
- To update firmware of the device connected
- Guided re-calibration

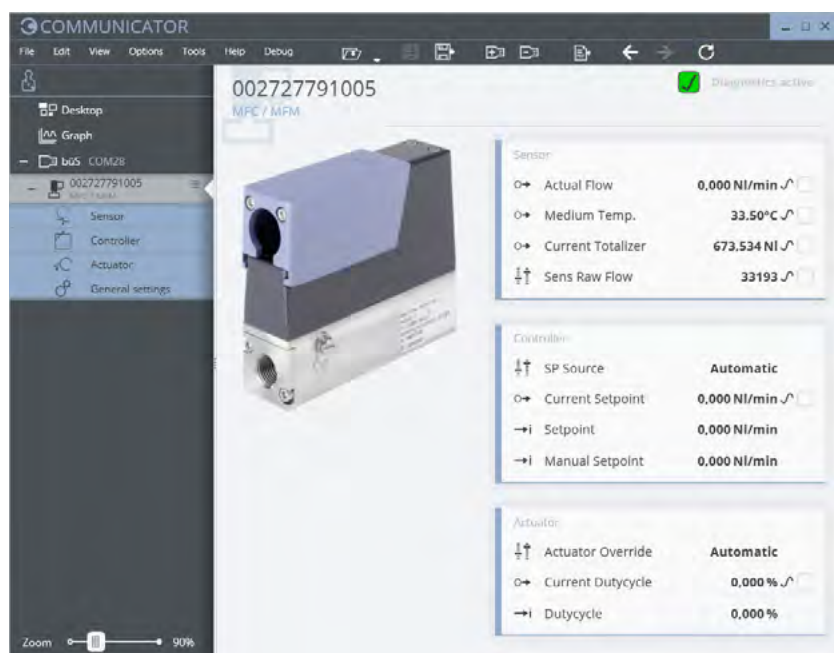

Type 8742 connection with Bürkert Communicator software

The interface to the "Bürkert Communicator" software tool is based on CANopen. The appropriate bus termination is mandatory. Hence, please activate, for Type 8742 with analogue or PROFIBUS interface, the termination resistor switch on the bÜS-stick. For Type 8742 bÜS / CANopen, this termination resistor should not be activated, in case the device is already integrated in a properly terminated bus network

To connect the MFC / MFM with the "Bürkert Communicator" software tool, you need a bÜS-stick. The bÜS-stick sets contain the necessary accessories.

- For Type 8742 bÜS / CANopen, the connection is made directly via the 5 pin M12 plug (bÜS-stick Set 1 contains the necessary accessories).
- For Type 8742, with analogue or PROFIBUS, the connection is made via the micro-USB socket on the device (bÜS-stick Set 2 contains the necessary accessories).

ATTENTION: No external power supply may be connected to the micro-USB socket! The power supply to the unit must be provided as described in chapter "5. Device/Process connections" on page 13.

10. Ordering information

10.1. Bürkert eShop – Easy ordering and quick delivery



Bürkert eShop – Easy ordering and fast delivery

You want to find your desired Bürkert product or spare part quickly and order directly? Our online shop is available for you 24/7. Sign up and enjoy all the benefits.

[Order online now](#)

10.2. Recommendation regarding product selection

Note:

The **product questionnaire form** at the end of this document contains the relevant fluid specification. Using the experience of Bürkert engineers already in the design phase provide us with a copy of the request containing the necessary data together with your inquiry or order.

For the proper choice of the actuator orifice within the MFC, not only the required maximum flow rate Q_{Nom} , but also the pressure values directly before and after the MFC (p_1 , p_2) at this flow rate Q_{Nom} should be known. In general, these pressures are not the same as the overall inlet and outlet pressures of the whole plant, because usually there are additional flow resistors (tubing, additional shut-off valves, nozzles etc.) present both before and after the controller.

Please use the **product questionnaire form** at the end of this document to indicate the pressures directly before and after the MFC. If these are unknown or not accessible to a measurement, estimates are to be made by taking into account the approximate pressure drops over the flow resistors before and after the MFC, respectively, at a flow rate of Q_{Nom} . In addition, please quote the maximum inlet pressure p_1 max. to be encountered. This data is needed to make sure the actuator is able to provide a close-tight function within all the specified modes of operation.

10.3. Bürkert product filter

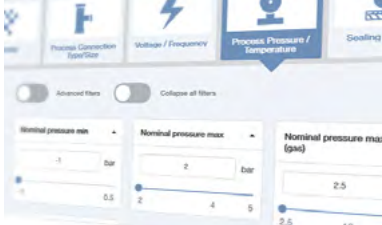

Bürkert product filter – Get quickly to the right product



You want to select products comfortably based on your technical requirements? Use the Bürkert product filter and find suitable articles for your application quickly and easily.

[Try out our product filter](#)

10.4. Ordering chart accessories

Note:

- A büS-Stick is required to connect the MFC / MFM with the “Bürkert Communicator” software tool. It is connected via the micro USB-socket on the device (büS-Stick Set 2 contains the necessary accessories).
- Please note: The interface to our software tool “Bürkert Communicator” is based on CANopen. A corresponding bus termination is mandatory. Therefore please activate the switchable terminating resistor on the büS-stick.

Description	Article no.
General accessories	
Power supply Type 1573 for rail mounting, 100...240 V AC / 24 V DC, 1.25 A, NEC Class 2 (UL 1310)	772438 
Power supply Type 1573 for rail mounting, 100...240 V AC / 24 V DC, 1 A, NEC Class 2 (UL 1310)	772361 
Power supply Type 1573 for rail mounting, 100...240 V AC / 24 V DC, 2 A, NEC Class 2 (UL 1310)	772362 
Power supply Type 1573 for rail mounting, 100...240 V AC / 24 V DC, 4 A	772363 